

# WATER SYSTEM IMPROVEMENTS CONTRACT B

# NEW BOOSTER STATION AND WATER TREATMENT PLANT IMPROVEMENTS FOR THE VILLAGE OF HOLGATE, OHIO

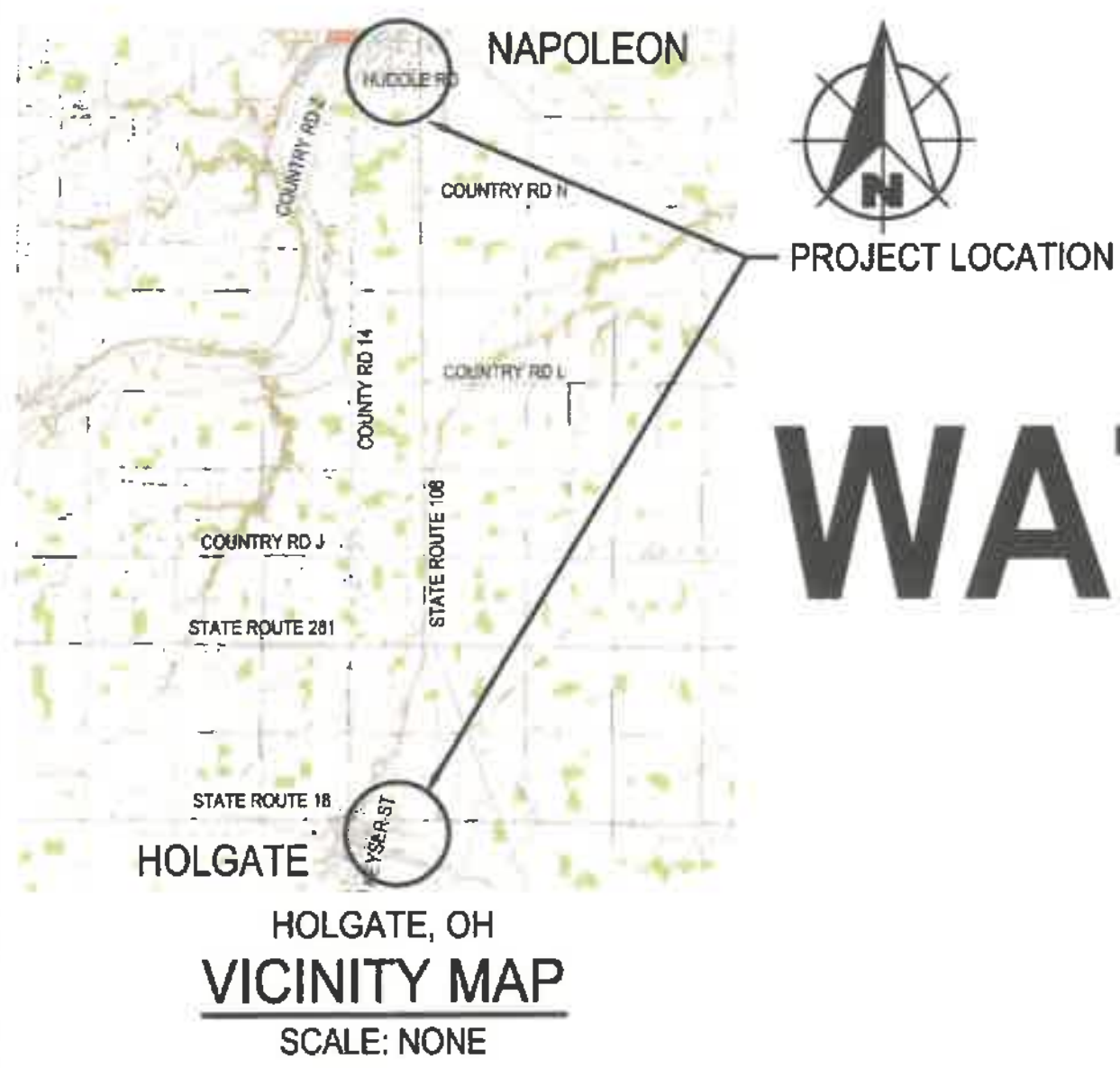

STATE LOCATION MAP  
SCALE: NONE



*More than a Project™*  
BLUFFTON  
80 State Route 103, Suite C  
Bluffton, Ohio 45817  
Phone: (419) 358-0521  
www.wesslerengineering.com

PROJECT NO. 703222-04-001

- DRAWINGS PREPARED FOR:
- VILLAGE COUNCIL
  - CHRIS HEALY, PRESIDENT
  - JAMIE HOHENBERGER, MEMBER
  - JEFFERY, ROTHMAN, MEMBER
  - NICHOLAS STEPHEY, MEMBER
  - MIKE MEDINA, MEMBER
  - RICARDO VALDEZ, MEMBER

**FEBRUARY 2026**

I HEREBY STATE THAT THESE PLANS HAVE BEEN PREPARED WITH OUR KNOWLEDGE AND CONCLURENCE AND REPRESENT OUR INTENT AND INTEREST

*[Signature]*  
ELVA POSADAS-WYANDT, MAYOR

*[Signature]*  
JASON MICHEL, VILLAGE ADMINISTRATOR

*[Signature]*  
CHAD LULFS, NAPOLEON DIRECTOR OF PUBLIC WORKS

	<i>[Signature]</i> ADAM SITKA REGISTERED ENGINEER STATE OF OHIO NO. E-88514
	<i>[Signature]</i> WAYNE C. MOORE REGISTERED ENGINEER STATE OF OHIO NO. E-70068 COVERING ELECTRICAL AND HVAC DESIGN
	<i>[Signature]</i> BAILEY HUSBAND REGISTERED ENGINEER STATE OF OHIO NO. E-91322 COVERING CONTROLS DESIGN
	<i>[Signature]</i> JAKOB C. BRUHL REGISTERED ENGINEER STATE OF OHIO NO. E-89802 COVERING STRUCTURAL DESIGN

Drawing: X:\Holgate\_CHT\703222-Holgate-WTP\Contract B - Booster Station and WTP\DWG\Sheets\703222-GS.dwg | Layout: 101 | Plotted: 01/20/26 @ 01:06:59 | LastSavedBy: Cmsc

**SURVEYORS REPORT  
VILLAGE OF HOLGATE WATERLINE**

BOCKRATH & ASSOCIATES ENGINEERING AND SURVEYING, LLC PERFORMED A TOPOGRAPHIC SURVEY OF APPROXIMATELY 9 MILES OF ROADWAY CONSISTING OF COUNTY ROAD 14 LOCATED IN SECTIONS 23, 24, 25, 26, 35, 36 OF NAPOLEON TOWNSHIP, TOWN 5 NORTH, RANGE 6 EAST, AND SECTIONS 1, 2, 11, 12, 13, 14, 23, 24, 25, 26, 35, & 36 OF FLATROCK TOWNSHIP, TOWN 4 NORTH, RANGE 6 EAST, AND JOE E BROWN AVENUE (STATE ROUTE 18) AND KEYSER STREET LOCATED IN THE VILLAGE OF HOLGATE. ALL WITHIN HENRY COUNTY, OHIO.

SURVEY CONTROL WAS PERFORMED IN SEPTEMBER, OCTOBER AND NOVEMBER 2024 AND JUNE 2025 AND WAS ESTABLISHED USING DUAL FREQUENCY TRIMBLE R10 GNSS SYSTEM. SUBSEQUENT SURVEY LOCATIONS WERE OBTAINED USING A COMBINATION OF THE GPS (RTK) AND TRIMBLE S5 ROBOTIC TOTAL STATION WITH A RELATIVE POSITIONAL ACCURACY OF 0.010 METERS. THE INITIAL CONTROL WAS SCALED TO GROUND USING A COMBINED SCALE FACTOR OF 1.0000795732. PROJECT WAS SCALED TO GROUND ON A RAILROAD SPIKE FOUND AT THE INTERSECTION OF COUNTY ROAD 14 AND COUNTY ROAD K. SAID RAILROAD SPIKE HAVING A NORTHING COORDINATE OF 603475.15 AND AN EASTING COORDINATE OF 1519649.37.

THE BASIS OF BEARINGS ARE BASED ON THE OHIO NORTH ZONE STATE PLANE COORDINATE SYSTEM, NAD 83, OBTAINED FROM THE OHIO DOT VRS NETWORK.

POINT NUMBER	GROUND COORDINATES			DESCRIPTION
	NORTHING	EASTING	ELEVATION	
2	581375.53	1521017.25	707.95	MAG
3	626394.72	1519888.42	675.89	MAG
22	581087.42	1520627.84	709.53	MAG
200019	627448.32	1519932.98	672.65	BENCHTIE SET IN UTILITY POLE
200037	581118.81	1520593.04	709.88	BENCHTIE SET IN UTILITY POLE
200038	581077.31	1520808.91	709.04	MAG SET IN PAVEMENT

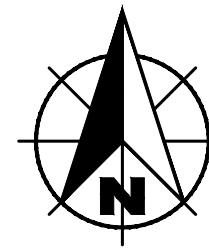

**LOCATION AND SCOPE OF WORK PLAN  
EXISTING WELLS**

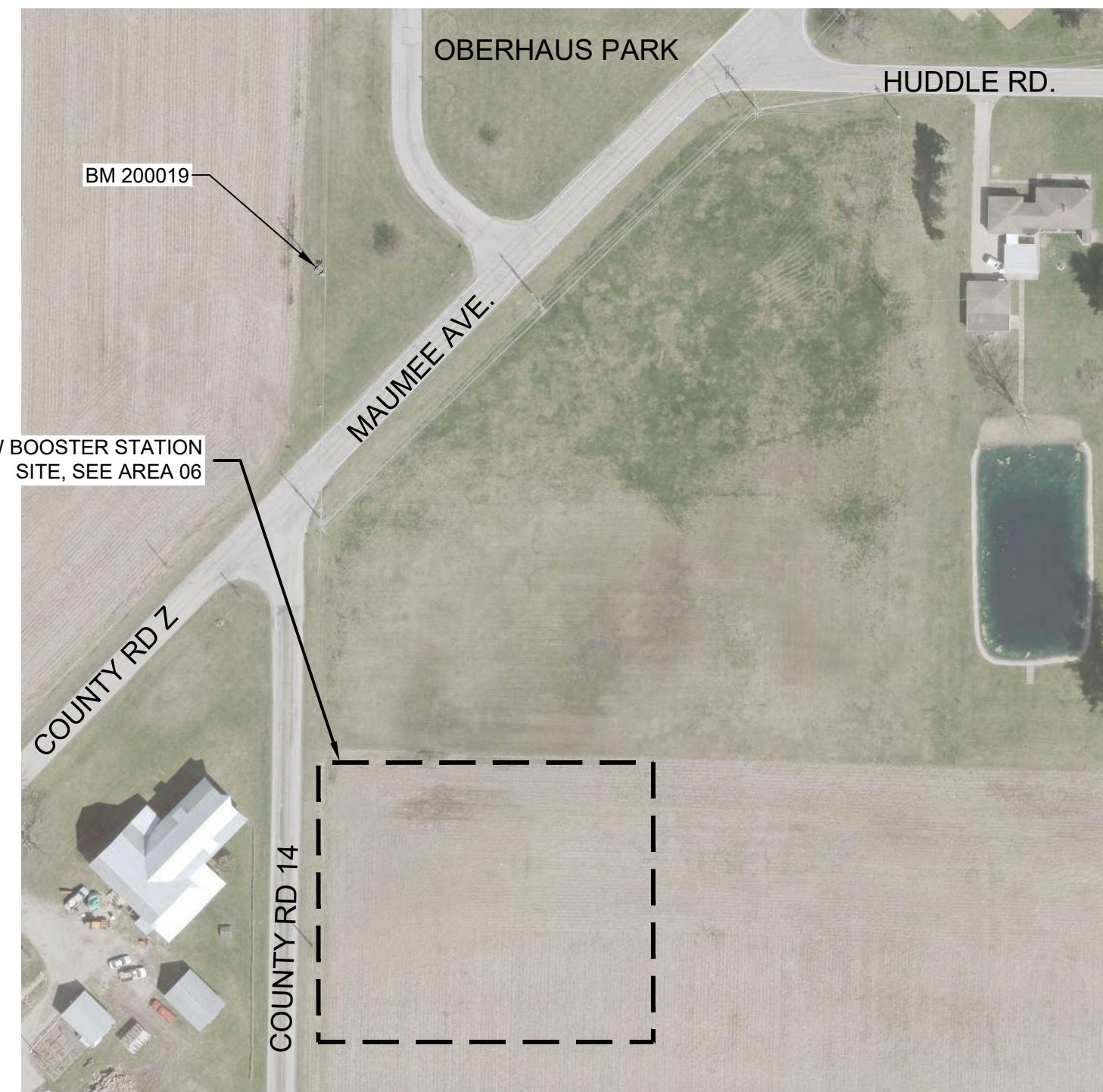
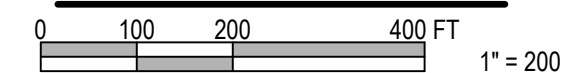

**LOCATION AND SCOPE OF WORK PLAN  
BOOSTER STATION**

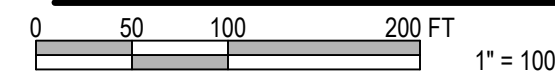

**LOCATION AND SCOPE OF WORK PLAN  
WATER TREATMENT PLANT AND ELEVATED WATER STORAGE TANK**

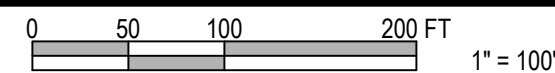

DRAWING INDEX	
NEW BOOSTER STATION AND WATER TREATMENT PLANT IMPROVEMENTS	
SHEET NUMBER	SHEET DESIGNATION
SHEET TYPE DEFINITIONS:	
	G - GENERAL
	Y - SITE
	EC - EROSION CONTROL
	D - DEMOLITION
	C - CIVIL / PROCESS
	S - STRUCTURAL
	M - MECHANICAL
	P - PLUMBING
	E - ELECTRICAL
	N - NETWORK
Area 1 - GENERAL	
1	1G1 COVER SHEET
2	1G2 LOCATION PLAN AND SCOPE OF WORK PLAN AND DRAWING INDEX
3	1G3 SYMBOLS, ABBREVIATIONS AND GENERAL NOTES
4	1S1 STRUCTURAL GENERAL NOTES
5	1M1 MECHANICAL SYMBOLS AND NOTATION
Area 2 - SITE	
6	2D1 EXISTING WATER TREATMENT PLANT - DEMOLITION SITE PLAN
7	2D2 EXISTING WATER TREATMENT PLANT - DEMOLITION NOTES
8	2D3 EXISTING WATER TREATMENT PLANT - SITE IMPROVEMENTS PLAN
9	2Y2 EXISTING WATER TREATMENT PLANT - SITE GEOMETRY PLAN
10	2Y3 EXISTING WATER TREATMENT PLANT - GRADING AND EROSION CONTROL PLAN
11	2Y4 NEW BOOSTER STATION - SITE IMPROVEMENTS PLAN
12	2Y5 NEW BOOSTER STATION - GRADING AND EROSION CONTROL AND SITE GEOMETRY PLAN
13	2E1 EXISTING WATER TREATMENT PLANT - ELECTRICAL SITE PLAN
14	2E2 NEW BOOSTER STATION - ELECTRICAL SITE PLAN
Area 3 - HIGH SERVICE PUMP BUILDING / NEW CHEMICAL BUILDING	
15	3D1 EXISTING HIGH SERVICE PUMP BUILDING DEMOLITION PLAN
16	3A1 NEW CHEMICAL BUILDING SECTIONS AND ELEVATIONS
17	3C1 NEW CHEMICAL AND EXISTING HIGH SERVICE PUMP BUILDINGS FLOOR PLAN
18	3M1 NEW CHEMICAL AND EXISTING HIGH SERVICE PUMP BUILDINGS HVAC PLAN
19	3E1 NEW CHEMICAL AND EXISTING HIGH SERVICE PUMP BUILDINGS ELECTRICAL PLAN
Area 4 - NEW WATER TREATMENT BUILDING	
20	4G1 PERSPECTIVE VIEWS
21	4A1 FLOOR PLAN
22	4A2 ELEVATIONS
23	4A3 SECTION AND ELEVATIONS
24	4P1 PLUMBING PLAN
25	4P2 PLUMBING ISOMETRICS
26	4M1 HVAC PLAN AND SECTIONS
27	4E1 POWER AND LIGHTING PLAN
Area 5 - EXISTING GROUND AND ELEVATED STORAGE TANKS MODIFICATIONS	
28	5C1 EXISTING GROUND STORAGE TANK - PLAN AND ELEVATIONS
29	5E1 EXISTING ELEVATED STORAGE TANK ELECTRICAL IMPROVEMENTS
Area 6 - NEW BOOSTER STATION	
30	6G1 PERSPECTIVE VIEWS
31	6A1 BUILDING ELEVATIONS
32	6C1 FLOOR PLAN
33	6C2 BUILDING SECTIONS
34	6S1 MONORAIL FRAME STRUCTURAL PLAN
35	6S2 MONORAIL FRAME SECTION AND DETAILS
36	6M1 HVAC PLAN
37	6E1 POWER PLAN
38	6E2 LIGHTING PLAN
Area 7 - MISCELLANEOUS DETAILS	
39	7MD1 MISCELLANEOUS DETAILS
40	7MD2 MISCELLANEOUS DETAILS
41	7MD3 MISCELLANEOUS DETAILS
42	7MD4 MISCELLANEOUS BUILDING DETAILS
43	7EC1 EROSION CONTROL DETAILS
44	7EC2 EROSION CONTROL DETAILS
45	7EC3 EROSION CONTROL DETAILS
Area 8 - ELECTRICAL	
46	8E1 ELECTRICAL LEGEND
47	8E2 WATER TREATMENT BUILDING POWER ONE LINE DIAGRAM
48	8E3 BOOSTER STATION POWER ONE LINE DIAGRAM
49	8E4 CONTROL ONE LINE DIAGRAM
50	8E5 ELECTRICAL SCHEDULES
51	8E6 ELECTRICAL DETAILS
52	8E7 CONTROL DETAILS
Area 9 - NETWORK	
53	9N1 PROCESS AND INSTRUMENTATION LEGEND
54	9N2 BOOSTER STATION PROCESS AND INSTRUMENTATION DIAGRAM
55	9N3 HSP AND TANK PROCESS AND INSTRUMENTATION DIAGRAM
56	9N4 CHEMICAL FEED PROCESS AND INSTRUMENTATION DIAGRAM
Area 10 - MECHANICAL	
57	10M1 MECHANICAL SCHEDULES
58	10M2 MECHANICAL SCHEDULES
59	10M3 MECHANICAL DETAILS AND SEQUENCES

Drawing: X:\Holgeatle\_Chi\703222\_Holgeatle WTP\Contract B - Booster Station and WTP\DWG Sheets\703222-04-001.dwg | Plotfile: 01/20/26 @ 01:17:04 | LastSavedBy: CurMS

SCALE VERIFICATION BAR IS ONE INCH LONG ON ORIGINAL DRAWING	DRAWN BY	CLG	NO.	DATE	INITIALS	REVISION DESCRIPTIONS
	CHECKED BY	MAP				
	APPROVED BY	AMS				
	ISSUE DATE	FEBRUARY 2026				
	PROJECT NUMBER	703222-04-001				

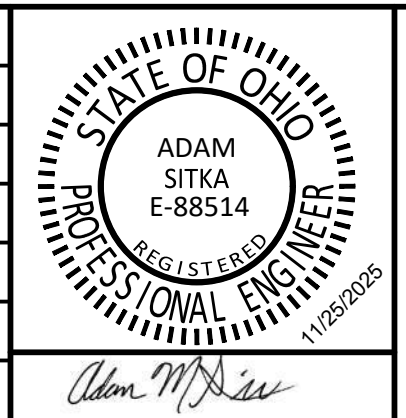

**WATER SYSTEM IMPROVEMENTS**

CONTRACT B NEW BOOSTER STATION AND WATER TREATMENT PLANT IMPROVEMENTS  
VILLAGE OF HOLGATE, OHIO

---

**LOCATION PLAN AND SCOPE OF WORK PLAN AND DRAWING INDEX**

SHEET NO.  
**1G2**

PAGE NO.  
**2**

DDAGW-4113



**EXISTING FEATURES LEGEND**

SYMBOL	DESCRIPTION	SYMBOL	DESCRIPTION	SYMBOL	DESCRIPTION
	BENCH MARK		CISTERN		EASEMENT - CONSTRUCTION/PERMANENT
	TEMPORARY BENCH MARK		ELECTRIC METER		LOT BOUNDARY
	SOIL BORING LOCATION		AIR CONDITIONING UNIT		PROPERTY BOUNDARY
	SECTION CORNER		UTILITY RISER (DEFINED BY UTILITY)		RIGHT-OF-WAY - TEMPORARY/PERMANENT
	DRILL HOLE IN CONCRETE/HARRISON MONUMENT		UTILITY PEDESTAL (DEFINED BY UTILITY)		SECTION BOUNDARY
	CONTROL POINT (SET/FOUND)		UTILITY MARKER (DEFINED BY UTILITY)		WETLANDS
	MAGNETIC NAIL (SET/FOUND)		JOINT POWER/TELEPHONE POLE		CONTOUR - INTERMEDIATE ELEVATION
	BOAT SPIKE (SET/FOUND)		LIGHT POLE		CONTOUR - INDEX ELEVATION
	PK NAIL (SET/FOUND)		LIGHT ON POWER POLE		OVERHEAD ELECTRIC
	RAILROAD SPIKE (SET/FOUND)		LIGHT ON JOINT POLE		OVERHEAD CABLE TV
	R/W MARKER - CONCRETE/GRANITE/STONE		POWER POLE		OVERHEAD TELEPHONE
	IRON PIPE/IRON PIN/REBAR (WITH DIAMETER)		TELEPHONE POLE		UNDERGROUND CABLE TV
	BRASS PLUG		LAMP POST		UNDERGROUND ELECTRIC
	CABLE TV MANHOLE		GUY ANCHOR		UNDERGROUND FIBER OPTIC
	ELECTRIC MANHOLE		GUY POLE OR STUB		GAS MAIN
	GAS MANHOLE		CONTROLLER CABINET		DIGESTER GAS
	OTHER MANHOLE		FLAG POLE		PETROLEUM MAIN
	TELEPHONE MANHOLE		POST		UNDERGROUND TELEPHONE
	TELEPHONE VAULT		GROUND LIGHT		WATER MAIN
	TRAFFIC MANHOLE		MAILBOX		WATER SERVICE
	TRAFFIC HANDHOLE		DOUBLE MULTIPLE MAILBOX		FORCE MAIN
	WATER MANHOLE		MAST ARM POLE		GRAVITY SEWER PIPE
	AIR RELEASE VALVE		TRAFFIC SIGNAL STRAIN POLE		PLANT CHLORINE PIPE
	SANITARY SEWER MANHOLE		SIGNAL LOOP DETECTOR BOX		TOP OF BANK/TOE OF SLOPE
	DRAINAGE/STORM SEWER MANHOLE		SIGNAL LOOP DETECTOR LOOP		CENTERLINE OF DITCH/SWALE/STREAM
	SANITARY SEWER CLEANOUT		SIGN - SINGLE POST		FENCE - FIELD
	SEPTIC TANK		SIGN - DOUBLE POST		FENCE - METAL
	VALVE VAULT		SIGN - RAILROAD SIGNAL		FENCE - WOOD
	BEEHIVE INLET		SIGN - RAILROAD CROSSING		GUARDRAIL
	CURB INLET		BUSH		STREAM
	DROP INLET		STUMP		TREE/BRUSH LINE
	CATCH BASIN		TREE - CONIFEROUS		
	DOWNSPOUT		TREE - DECIDUOUS		
	GAS METER		ROCK OUTCROP		
	GAS VALVE		SATELLITE		
	GAS SERVICE VALVE		SPRINKLER CONTROL VALVE		
	PETROLEUM VALVE		WATER METER		
	PETROLEUM SHUTOFF VALVE		WATER VALVE		
	GAS STATION MONITORING WELL		WATER SERVICE VALVE		
	GAS STATION FILL CAP		WATER WELL		
	NATURAL GAS WELL/STORAGE WELL		WET WELL		
	SPRINKLER HEAD		WET WELL		
	YARD HYDRANT		PROCESS VALVE		

\*NOTE: THIS TABLE IS A LISTING OF TYPICAL SYMBOLS AND MAY NOT INCLUDE ALL EXISTING SYMBOLS FOUND WITHIN THIS PLAN SET. UNDESIGNED ITEMS WILL BE CALLED OUT ON THEIR PLAN SHEETS. IF A QUESTION ARISES ON THE MEANING OF ANY SYMBOL NOT LISTED IN THIS TABLE, PLEASE CONTACT THE ENGINEER FOR CLARIFICATION. THE SYMBOLS ARE NOT TO SCALE.

**TABLE OF ABBREVIATIONS**

ABBREVIATION	DESCRIPTION	ABBREVIATION	DESCRIPTION
AFF	ABOVE FINISHED FLOOR	IPS	IRON PIPE SIZE
ALUM	ALUMINUM	LB	POUND(S)
APP	APPARENT	LF	LINEAR FEET
APPROX	APPROXIMATE(LY)	LN	LANE
ASPH	ASPHALT	LS	LIFT STATION
ASSOC	ASSOCIATES	MA EX	MATCH EXISTING
ASTM	AMERICAN SOCIETY OF TESTING MATERIALS	MJ	MECHANICAL JOINT
AVE	AVENUE	MATL	MATERIAL
AVG	AVERAGE	MAX	MAXIMUM
BLDG	BUILDING	MH	MANHOLE
BLVD	BOULEVARD	MIN	MINIMUM
BM	BENCHMARK	MISC	MISCELLANEOUS
CO	CLEANOUT	MNFR	MANUFACTURER
CI	CAST IRON	N	NORTHING, NORTH
CL	CENTER LINE	NGS	NATIONAL GEODETIC SURVEY
CMA	COLD MIX ASPHALT	NO.	NUMBER
CMP	CORRUGATED METAL PIPE	OC	ON CENTER
CMU	CONCRETE MASONRY UNIT	OD	OUTSIDE DIAMETER
CONC	CONCRETE	ODOT	OHIO DEPARTMENT OF TRANSPORTATION
CONT	CONTINUOUS	PC	POINT OF CURVE (BEGIN CURVE)
CNR	CORNER	POLY	POLYETHYLENE
CP	CONTROL POINT	PI	POINT OF INTERSECTION
CPP	CORRUGATED PLASTIC PIPE	POT	POINT ON TANGENT
CR STN	CRUSHED STONE	PT	POINT OF TANGENT (END OF CURVE)
CYD	CUBIC YARD	PSI	POUNDS PER SQUARE INCH
D	DEPTH	PT	POINT
DI	DUCTILE IRON	PVC	POLYVINYL CHLORIDE
DI MJ	DUCTILE IRON MECHANICAL JOINT	R	RAILROAD
DBL	DOUBLE	ROW	RIGHT-OF-WAY
DIA	DIAMETER	RCP	REINFORCED CONCRETE PIPE
DIP	DUCTILE IRON PIPE	R	ROAD
DIPS	DUCTILE IRON PIPE SIZE	S	SOUTH
DR	DRIVE	SR	STATE ROUTE
E	EASTING, EAST	SST	STAINLESS STEEL
EF	EACH FACE	SVA	SERVICE VALVE ASSEMBLY
EW	EACH WAY	SB	SOIL BORING
EA	EACH	SCHED	SCHEDULE
EJ	EAST SIDE IRON WORKS	SDR	STANDARD DIMENSION RATIO
EL	ELEVATION	SECT	SECTION
EX	EXISTING	SF	SQUARE FEET
EXP	EXPANSION	SHT	SHEET
FIN	FINISH FLOOR ELEVATION	SPECS	SPECIFICATION(S)
FM	FORCE MAIN	SQ	SQUARE
FND	FOUND	SRF	STATE REVOLVING FUND
FT	FEET	ST	STREET
FTG	FOOTING	STA	STATION
GALV	GALVANIZED	SYD	SQUARE YARD
GPS	GLOBAL POSITIONING SYSTEM	TBM	TEMPORARY BENCHMARK
HMA	HOT MIX ASPHALT	TC	TOP OF CASTING
HDPE	HIGH DENSITY POLYETHYLENE	TYP	TYPICAL
HORIZ	HORIZONTAL	UNO	UNLESS NOTED OTHERWISE
ID	INSIDE DIAMETER	USGS	US GEOLOGICAL SURVEY
IE	INVERT ELEVATION	VERT	VERTICAL
INC	INCORPORATED	VLV	VALVE
INSTR	INSTRUMENT	W	WIDTH, WEST
INV	INVERT	WSE	WATER SURFACE ELEVATION
		YR	YEAR

\*NOTE: THIS TABLE IS A LISTING OF TYPICAL ABBREVIATIONS AND MAY NOT INCLUDE ALL ABBREVIATIONS FOUND WITHIN THIS PLAN SET. IF A QUESTION ARISES ON THE MEANING OF AN ABBREVIATION NOT LISTED IN THIS TABLE, PLEASE CONTACT THE ENGINEER FOR CLARIFICATION.

**GENERAL NOTES:**

- NOTIFY THE ENGINEER IF ANY CONFLICTING INFORMATION BECOMES APPARENT IN THE CONTRACT DOCUMENTS AS SOON AS POSSIBLE AND PRIOR TO THE COMMENCEMENT OF ANY WORK IN THE VICINITY OF OR RELATIVE TO THE APPARENT CONFLICT SO THAT CLARIFICATION MAY OCCUR PRIOR TO CONSTRUCTION.
- ANY ALTERATIONS TO THESE DRAWINGS NOT AUTHORIZED BY WESSLER ENGINEERING AND NOT IN ACCORDANCE WITH THE DRAWINGS, SPECIFICATIONS AND RECORDS ON FILE AT WESSLER ENGINEERING SHALL RELIEVE WESSLER ENGINEERING OF ANY RESPONSIBILITY FOR THE ACCURACY OF THE DRAWINGS. USE CAUTION DURING THE EXECUTION OF WORK TO PREVENT DAMAGE TO STATE, COUNTY, MUNICIPAL, AND PRIVATE PROPERTY. REPAIR ALL DAMAGES AS A RESULT OF OPERATIONS, INCLUDING DAMAGE TO DRAINAGE STRUCTURES, FIELD TILES, PUBLIC/PRIVATE ROADS, AND LANDSCAPING (INCLUDING FENCING). REPAIR AND REPLACE DAMAGED ITEMS AT NO ADDITIONAL COST TO THE OWNER. PERFORM ALL REPAIR AND REPLACEMENT WORK TO THE SATISFACTION OF THE PERMITTING AGENCY, THE OWNER AND THE ENGINEER. TAKE CARE TO AVOID DAMAGE TO PAVED AREAS WHICH ARE NOT SPECIFICALLY CALLED OUT FOR REPAIR OR REPLACEMENT. REPAIR, OR REPLACE ALL SUCH PAVEMENTS WHICH ARE DAMAGED BY CONSTRUCTION ACTIVITIES AND CONSTRUCTION TRAFFIC AT NO ADDITIONAL COST TO THE OWNER.
- OBTAIN ALL TEMPORARY EASEMENTS REQUIRED FOR THE CONSTRUCTION OF THE PROJECT AT NO ADDITIONAL COST TO THE OWNER.
- COMPLY WITH ALL APPLICABLE PERMITS AND REGULATIONS. APPLICABLE PERMITS ISSUED TO THE OWNER WILL BE MADE AVAILABLE TO THE CONTRACTOR. CONTACT ALL APPLICABLE PERMITTING AGENCIES WITHIN THE TIME PERIOD SPECIFIED BY THAT AGENCY PRIOR TO BEGINNING CONSTRUCTION.
- ALL PRIVATE WELL LOCATIONS SHOWN ON THE DRAWINGS ARE APPROXIMATE. FIELD VERIFY AND DETERMINE EXACT LOCATIONS OF ALL PRIVATE WELLS IN THE PROJECT AREA.
- ALL EXISTING AND NEW UTILITY INFORMATION, INCLUDING BUT NOT LIMITED TO LOCATION, SIZE AND INVERT ELEVATION, IS SHOWN BASED UPON AVAILABLE INFORMATION. THE ENGINEER DOES NOT GUARANTEE OR ASSUME SUCH INFORMATION TO BE TRUE OR ACCURATE. WELL INCLUSIVE OR EVEN APPROXIMATE. CONTACT THE OHIO UNDERGROUND PLANT PROTECTION SERVICE (OUPPS) AT LEAST FORTY-EIGHT (48) HOURS IN ADVANCE OF ANY CONSTRUCTION ACTIVITY. CONTACT NON-MEMBER UTILITIES DIRECTLY.
- DETERMINE WHICH UTILITIES MAY CONFLICT WITH WORK AND VERIFY THEIR LOCATION, SIZE AND ELEVATION PRIOR TO CONSTRUCTION. FIELD VERIFY AND DETERMINE IF THERE ARE ANY DISCREPANCIES OR CONFLICTS. IF ANY DISCREPANCIES OR CONFLICTS ARE DISCOVERED, NOTIFY THE ENGINEER AS SOON AS POSSIBLE.
- EXISTING UTILITY SERVICE LINES TO INDIVIDUAL CUSTOMERS MAY NOT BE SHOWN ON THE DRAWINGS. ASSUME THAT ALL UNDERGROUND SERVICE LINES FOR ALL UTILITIES EXIST TO EACH PROPERTY ALONG THE ROUTE OF THE PLANNED IMPROVEMENTS.
- COORDINATE ALL WORK WITH THE RESPECTIVE UTILITIES. SCHEDULE WORK ACCORDINGLY, AND NOTIFY ALL UTILITIES A MINIMUM OF TWO (2) WEEKS IN ADVANCE OF ANY CONSTRUCTION ACTIVITY.
- COORDINATE PLANNED UTILITY SERVICE INTERRUPTIONS WITH THE RESPECTIVE UTILITIES AND THE UTILITIES' AFFECTED CUSTOMERS. SERVICE INTERRUPTIONS SHOULD NOT LAST MORE THAN FOUR (4) HOURS. GIVE WRITTEN NOTICE TO ALL AFFECTED UTILITY CUSTOMERS AND PROPERTY OWNERS AT LEAST TWENTY-FOUR (24) HOURS BUT NOT MORE THAN SEVENTY-TWO (72) HOURS PRIOR TO ANY PLANNED INTERRUPTION OF UTILITY SERVICE.
- USE CAUTION DURING THE EXECUTION OF WORK TO PREVENT DAMAGE TO EXISTING UTILITIES. REPAIR OR REPLACE ALL PUBLIC AND PRIVATE FACILITIES DAMAGED AS A RESULT OF CONSTRUCTION OPERATIONS. BRACE AND PROTECT ALL UTILITY POLES AND EXISTING STRUCTURES ADJACENT TO NEW EXCAVATIONS. UTILITY POLE BRACING SHALL BE AS DIRECTED BY THE GOVERNING UTILITY.
- MAINTAIN EXISTING STORMWATER DRAINAGE FOR THE ENTIRE DURATION OF THE PROJECT.
- DO NOT DISTURB EXISTING MANHOLES OR INLETS, UNLESS NOTED OTHERWISE.
- ALL EQUIPMENT, APPURTENANCES AND PIPING REMOVED AS PART OF THE DEMOLITION SHALL FIRST BE OFFERED TO THE OWNER FOR SALVAGE. DELIVER SALVAGED ITEMS SELECTED BY OWNER TO A LOCATION DESIGNATED BY THE OWNER OR ENGINEER. IN THE EVENT THE OWNER DOES NOT ELECT TO KEEP THE REMOVED ITEMS, REMOVE SUCH ITEMS FROM THE SITE AND DISPOSE OF AT A LOCATION APPROVED FOR SUCH DISPOSAL AT THE CONTRACTOR'S EXPENSE.
- COORDINATE STAGING AREA LOCATIONS WITH THE OWNER.
- ALL CONSTRUCTION TRAFFIC SHALL USE MAJOR ROADS. NO CONSTRUCTION TRAFFIC SHALL USE LOCAL STREETS FOR INDIRECT ACCESS.
- TO CONTROL DUST, REMOVE SOIL FROM STREETS USED BY CONSTRUCTION TRAFFIC DAILY. VACUUM AND WATER AS NECESSARY AND/OR AS DIRECTED BY THE OWNER.
- ALL EXISTING PIPING MAY NOT BE SHOWN. REFERENCE EXISTING RECORD DRAWINGS ON FILE WITH THE OWNER AND WESSLER ENGINEERING FOR ADDITIONAL INFORMATION OF EXISTING PIPING AND CONDUIT THROUGHOUT THE PLANT SITE.
- THE WORK SHOWN ON THESE DRAWINGS IS OCCURRING ON A PLANT SITE IN WHICH BURIED ELECTRICAL CONDUIT AND SMALL PIPING MAY EXIST THROUGHOUT AND IN THE VICINITY OF THE PROJECT AND MAY NOT BE SHOWN ON THESE DRAWINGS. EXPECT TO ENCOUNTER BURIED ELECTRICAL AND COMMUNICATIONS WIRING, WITH OR WITHOUT CONDUIT, SMALL PIPING, AND FIELD TILE WHILE DIGGING ON THIS SITE.
- NEW PIPING CARRYING LIQUIDS SHALL HAVE MINIMUM COVER AS DEFINED IN SPEC 02660, UNLESS SPECIFIC ELEVATIONS ON THE DRAWINGS INDICATE OTHERWISE. (60 INCHES)
- INSPECT THE SITE PRIOR TO BIDDING TO UNDERSTAND THE EXTENT OF THE DEMOLITION WORK INVOLVED AND ADJUST BID ACCORDINGLY.
- COMPLETELY REMOVE UNDERGROUND PIPING THAT HAS PREVIOUSLY BEEN OR WILL BE TAKEN OUT OF SERVICE, IN CONFLICT WITH THE NEW WORK. UNLESS OTHERWISE NOTED, ABANDON IN PLACE ALL UNDERGROUND PIPING NOT IN CONFLICT WITH THE NEW WORK. DO NOT LEAVE ABANDONED PIPING LIVE. SEE SPECIFICATION SECTION 02050 FOR DEMOLITION PROCEDURES. SEE SPECIFICATION SECTION 01550 FOR PLANT OPERATIONS DURING CONSTRUCTION FOR COORDINATION OF DEMOLITION WORK AND NEW CONSTRUCTION.
- ALL EQUIPMENT TO BE REMOVED THAT HAS ELECTRICAL COMPONENTS, CONDUIT AND WIRING, OR SMALL PIPING CONNECTED SHALL HAVE THE ELECTRICAL COMPONENTS AND SMALL PIPING REMOVED BACK TO THE SOURCE.
- LENGTHS OF SEWERS AS SHOWN ON THE DRAWINGS AND INDICATED AS LINEAR FEET (LF) ARE FROM CENTER TO CENTER OF STRUCTURES.

**UTILITY CONTACTS**

**WATER AND SEWER**

VILLAGE OF HOLGATE  
101 KAUFMAN ST.  
HOLGATE, OH 43527  
419-604-0145  
ATTN: JASON MICHEL

CITY OF NAPOLEON  
255 W. RIVERVIEW AVE.  
NAPOLEON, OH 43545  
419-592-4010  
ATTN: CHAD LULFS

**NATURAL GAS**

OHIO GAS COMP ANY - WAUSEON  
715 E. WILSON ST  
BRYAN, OH 43506  
419-630-2233  
ATTN: KRIS HANDSHOE

**INTERNET**

BRIGHTSPEED  
952-500-1596  
ATTN: BILL PARSONS

**NATURAL GAS TRANSMISSION MAIN**

ENERGY TRANSFER  
3990 CROOKED LAKE RD.  
HOWELL, MI 48843  
419-309-2885  
ATTN: RUSSEL LAYFIELD

**TELEPHONE**

AYERSVILLE TELEPHONE  
27932 WATSON RD.  
DEFIANCE, OH 43512  
419-395-2222  
ATTN: PHIL MAAG

**RIDGEVILLE TELEPHONE**

S732 CO. RD. 20B  
RIDGEVILLE CORNERS, OH 43555  
419-267-5285  
ATTN: DAVID GOBROGGE

**ELECTRIC**

TOLEDO EDISON (USIC)  
900 LEMOYNE RD  
NORTHWOOD, OH 43619  
419-249-5094  
ATTN: BRENT THORNE

TRI COUNTY RURAL ELECTRIC COOPERATIVE  
8945 COUNTY ROAD K2  
MALINTA, OH 43535  
ATTN: CHRIS OKULEY

**OTHER**

BRIGHTSPEED (STAKE CENTER)  
952-500-1596  
ATTN: BILL PARSONS

Drawing: X:\Holgeat\_Oh\703222\_Holgeat\_Village\DWG\Sheets\703222-GS.dwg | Plotter: G3 | Plotlet: 01/20/26 @ 01:07:12 | LastSavedBy: CurlyG

For Viewing Purposes Only - Visit [www.wesslerengineering.com](http://www.wesslerengineering.com) to purchase

Ohio Utilities Protection Service  
Call 811  
before you dig

SCALE VERIFICATION  BAR IS ONE INCH LONG ON ORIGINAL DRAWING	DRAWN BY	CLG	NO.	DATE	INITIALS	REVISION DESCRIPTIONS
	CHECKED BY	MAP				
	APPROVED BY	AMS				
	ISSUE DATE	FEBRUARY 2026				
	PROJECT NUMBER	703222-04-001				

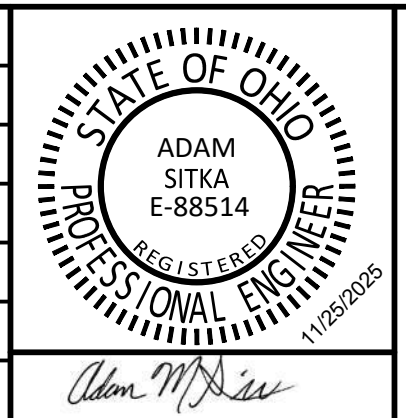

**WATER SYSTEM IMPROVEMENTS**

CONTRACT B NEW BOOSTER STATION AND WATER TREATMENT PLANT IMPROVEMENTS  
VILLAGE OF HOLGATE, OHIO

**SYMBOLS, ABBREVIATIONS AND GENERAL NOTES**

SHEET NO.	1G3
PAGE NO.	3
	DDAGW-4113



Drawing: X:\Hogdale\_Cht\703222\_Hogdale WTP\Contract B - Booster Station and WTP\DWG Sheets\703222-SS.dwg | Layout: IS1 | Plotter: 01/20/26 @ 01/07/13 | LastSavedBy: CurfSG

For Viewing Purposes Only - Visit [www.wesslerengineering.com](http://www.wesslerengineering.com) to Purchase

**STRUCTURAL GENERAL NOTES**

**A. GENERAL INFORMATION**

1. SHOP DRAWINGS OF ALL FABRICATED ITEMS SHALL BE SUBMITTED FOR REVIEW PRIOR TO FABRICATION.
2. VERIFY DIMENSIONS AND DETAILS BEFORE BEGINNING WORK. COORDINATE WALL OPENINGS WITH PROCESS / MECHANICAL / ARCHITECTURAL DRAWINGS. CONTRACTOR SHALL CHECK AND COORDINATE SIZES AND LOCATIONS OF ALL BLOCK-OUTS, CONDUITS, PIPE SLEEVES, EMBEDDED ITEMS, ETC. WITH MECHANICAL AND ELECTRICAL.
3. EXISTING CONDITIONS ARE TO BE VERIFIED IN THE FIELD BY THE CONTRACTOR. VERIFICATION IS THE RESPONSIBILITY OF THE CONTRACTOR. CONTRACTOR IS TO IMMEDIATELY NOTIFY THE ENGINEER OF ANY DISCREPANCIES OR CONFLICTS BETWEEN EXISTING CONDITIONS AND DESIGN AND DETAILS INDICATED BY THESE DRAWINGS.
4. DETAILS NOT SPECIFICALLY INDICATED SHALL BE SIMILAR TO DETAILS SHOWN FOR SIMILAR CONDITIONS.

**B. DESIGN**

**1. CODES AND SPECIFICATIONS**

- a. 2024 OHIO BUILDING CODE (2021 INTERNATIONAL BUILDING CODE).
- b. ASCE 7- 16: MINIMUM DESIGN LOADS FOR BUILDINGS AND OTHER STRUCTURES.
- c. ACI 318-19: BUILDING CODE REQUIREMENTS FOR REINFORCED CONCRETE.
- d. ACI 350-06: CODE REQUIREMENTS FOR ENVIRONMENTAL ENGINEERING CONCRETE STRUCTURES.
- e. ACI 301-16: SPECIFICATION FOR STRUCTURAL CONCRETE FOR BUILDINGS.
- f. ACI 315: DETAILS AND DETAILING OF CONCRETE REINFORCING.
- g. AISC 360-16: SPECIFICATIONS FOR STRUCTURAL STEEL FOR BUILDINGS.
- h. AMERICAN WELDING SOCIETY STANDARDS AND SPECIFICATIONS (AWS).

**C. FOUNDATIONS**

1. FOUNDATIONS ARE DESIGNED BASED ON RECOMMENDATIONS CONTAINED IN THE SUBSURFACE INVESTIGATION & FOUNDATION RECOMMENDATIONS REPORT PREPARED BY PATRIOT ENGINEERING AND ENVIRONMENTAL, IN., DATED JUNE 20, 2025

2. FOUNDATIONS ARE DESIGNED FOR THE FOLLOWING "NET" ALLOWABLE BEARING PRESSURE ( PSF ):

STRUCTURE DESCRIPTION( PSF )	
BOOSTER STATION	2500

3. CONSTRUCT FOOTINGS ON ADEQUATE SUBGRADE SOIL OR ENGINEERED FILL. IN ADDITION, PLACE 8 INCHES OF #57 OR #67 STONE BELOW ALL STRUCTURES.

4. PROOFROLL EXPOSED FOUNDATION AND SLAB ON GRADE SUBGRADE SOILS TO DELINEATE SOFT SOILS. REMOVE ANY UNSUITABLE SOIL AND REPLACE WITH WELL COMPACTED GRANULAR MATERIAL.

5. ALL FOUNDATION EXCAVATIONS SHALL BE INSPECTED BY A QUALIFIED GEOTECHNICAL ENGINEER OR HIS REPRESENTATIVE. VERIFY THAT THE STRUCTURE SUBGRADE MATERIALS ARE SUITABLE AND ARE CONSISTENT WITH THE SUBSURFACE INVESTIGATION & FOUNDATION RECOMMENDATIONS REPORT IDENTIFIED ABOVE. THE CONTRACTOR IS RESPONSIBLE FOR THE COST OF THIS REQUIREMENT.

6. PARTIAL DEPTH OVER EXCAVATION IS REQUIRED BELOW THE FOLLOWING STRUCTURES:

AREA	STRUCTURE	ESTIMATED DEPTH
1	BOOSTER STATION	5 FT

SEE SUBSURFACE INVESTIGATION & FOUNDATION RECOMMENDATIONS REPORT IDENTIFIED ABOVE.

**D. CONCRETE**

1. REINFORCING SHALL BE DETAILED ACCORDING TO THE ACI BUILDING MANUAL.
2. CAST-IN-PLACE CONCRETE SHALL HAVE A MINIMUM COMPRESSIVE STRENGTH AT 28 DAYS OF 4500 PSI UNLESS OTHERWISE NOTED.
3. THE FOLLOWING CONCRETE COVER SHALL BE PROVIDED FOR REINFORCEMENT UNLESS OTHERWISE INDICATED:
  - a. CONCRETE CAST AGAINST AND PERMANENTLY EXPOSED TO EARTH: 3 INCHES.
  - b. CONCRETE EXPOSED TO EARTH WEATHER OR FLUID SURFACES BUT CAST AGAINST FORMS: 2 INCHES.
  - c. SLABS: 1 INCH
4. REINFORCING DETAILS SHOWN REPRESENT MINIMUM REQUIREMENTS. ALTERNATE BUT EQUAL METHODS ARE ACCEPTABLE, BUT THEY SHALL NOT BE USED WITHOUT PRIOR APPROVAL BY THE ENGINEER. SEE SPECIFICATION SECTION 03200 "CONCRETE REINFORCEMENT" FOR SHOP DRAWING REQUIREMENTS.
5. REINFORCING BARS: BILLET STEEL, DEFORMED BARS TO COMPLY WITH ASTM A615, GRADE 60.
6. IF CONTRACTOR DESIRES TO INCREASE SLUMP ABOVE ALLOWABLE LIMITS INDICATED IN THE SPECIFICATION TO FACILITATE PLACEMENT OR PUMPING, THIS SHALL BE DONE UTILIZING AN APPROPRIATE APPROVED ADMIXTURE. NO WATER SHALL BE ADDED AT THE PROJECT SITE WITHOUT THE ENGINEER'S APPROVAL. ALL ADMIXTURES ARE TO BE SUBMITTED WITH THE CONCRETE MIX DESIGN AND ARE TO BE APPROVED PRIOR TO USE. CONCRETE WITH HIGH-RANGE WATER REDUCING ADMIXTURE SHALL HAVE A MAXIMUM SLUMP OF 3 INCHES PRIOR TO ADDING ADMIXTURE. THE CONTRACTOR, IN COLLABORATION WITH THE CONCRETE SUPPLIER, SHALL TAKE APPROPRIATE STEPS TO COMPENSATE FOR THE LOSS OF AIR-ENTRAINMENT DURING PUMPING.
7. WHERE NEW CONCRETE IS DEPOSITED AGAINST CONCRETE THAT IS GREATER THAN 28 DAYS OLD, THOROUGHLY CLEAN EXISTING SURFACE OF LAITANCE AND FOREIGN MATERIAL, AND APPLY BONDING AGENT FOLLOWING RECOMMENDATIONS OF MANUFACTURER.
8. ALL CONCRETE IS REINFORCED UNLESS SPECIFICALLY NOTED AS UNREINFORCED. REINFORCE ALL CONCRETE NOT OTHERWISE SHOWN WITH THE SAME REINFORCING AS IN SIMILAR SECTIONS OR AREAS.

**E. STRUCTURAL STEEL**

1. STRUCTURAL STEEL SHALL MEET ASTM A992, GRADE 50, EXCEPT AS FOLLOWS:
  - ANGLES AND PLATES SHALL MEET ASTM A36.
  - S SHAPES SHALL MEET ASTM A572, GRADE 50, FY = 50 KSI.
  - HSS SECTIONS SHALL MEET ASTM A500, GRADE C, FY = 50 KSI.
  - STEEL PIPE SHALL MEET ASTM A501 OR ASTM A53, GRADE B, FY = 35 KSI.
  - HEADED STUDS SHALL MEET ASTM A108 TYPE B, FU = 65 KSI.
  - STAINLESS STEEL: TO ASTM A276, TYPE 304, CLASS A
  - ANCHOR RODS: SHALL CONFORM TO ASTM F 1554, GRADE 36.
  - BOLTS, NUTS, AND WASHERS: TO ASTM A325, A563 AND A436 RESPECTIVELY.
  - BEVELED WASHERS REQUIRED FOR S BEAMS AND AT OTHER SLOPED CONNECTION SURFACES.
2. WELDING: AWS STANDARDS AND SPECIFICATIONS.
3. GROUT UNDER COLUMN BASE PLATES WITH 1 1/2 INCH MINIMUM NON-SHRINK GROUT, UNLESS OTHERWISE NOTED.
4. ALL METALS TO BE COATED IN ACCORDANCE WITH SPECIFICATION SECTION 09801

**F. SPECIAL INSPECTIONS AND TEST**

THE OWNER OR THE OWNER'S REPRESENTATIVE, OTHER THAN THE CONTRACTOR, IS TO EMPLOY ONE OR MORE SPECIAL INSPECTORS TO PROVIDE SPECIAL INSPECTIONS AND TESTS FOR THE FOLLOWING ITEMS AS OUTLINED IN CHAPTER 17 OF THE 2024 OHIO BUILDING CODE (OBC):

1. STEEL CONSTRUCTION PER OBC 1705.2 AND REQUIREMENTS OF AISC 360 (QA); DOCUMENT ACCEPTANCE OR REJECTION OF BOLTED CONNECTIONS.
2. CONCRETE CONSTRUCTION PER OBC 1705.3
  - a. INSPECT REINFORCEMENT AND VERIFY PLACEMENT. (PERIODIC)
  - b. INSPECT ANCHORS CAST IN CONCRETE. (PERIODIC)
  - c. VERIFY USE OF REQUIRED DESIGN MIX. (CONTINUOUS)
  - d. PERFORM STRENGTH TESTS, SLUMP AND AIR CONTENT TESTS, AND DETERMINE TEMPERATURE OF CONCRETE. (CONTINUOUS)
  - e. INSPECT CONCRETE PLACEMENT FOR PROPER APPLICATION TECHNIQUES. (CONTINUOUS)
  - f. VERIFY MAINTENANCE OF SPECIFIED CURING TEMPERATURE AND TECHNIQUES. (PERIODIC)
  - g. INSPECT FORMWORK FOR SHAPE, LOCATION AND DIMENSIONS OF THE CONCRETE MEMBERS BEING FORMED. (PERIODIC)
3. SOILS PER OBC 1705.6
  - a. VERIFY MATERIALS BELOW SHALLOW FOUNDATIONS ARE ADEQUATE TO SUPPORT THE DESIGN BEARING CAPACITY. (PERIODIC)
  - b. VERIFY EXCAVATIONS ARE EXTENDED TO PROPER DEPTH AND HAVE BEEN FILLED WITH PROPER MATERIAL. (PERIODIC)
  - c. DURING PLACEMENT OF FILL, VERIFY USE OF PROPER MATERIALS, VERIFY DENSITIES AND LIFT THICKNESSES DURING PLACEMENT AND COMPACTION OF COMPACTED FILL. (CONTINUOUS)
  - d. PRIOR TO PLACEMENT OF COMPACTED FILL, CHECK SUBGRADE AND VERIFY THAT SITE HAS BEEN PREPARED PROPERLY. (PERIODIC)
4. CONTRACTOR TO PROVIDE ALL LABOR, MATERIALS, TOOLS, EQUIPMENT AND INCIDENTALS AS REQUIRED TO COOPERATE WITH INDIVIDUAL SPECIAL INSPECTOR AND TESTING AGENCIES EMPLOYED BY THE OWNER TO FACILITATE SPECIAL INSPECTIONS.
5. CONTRACTOR TO NOTIFY SPECIAL INSPECTION LABORATORY AT LEAST 48 HOURS PRIOR TO START OF WORK.
6. STRUCTURAL OBSERVATIONS PER OBC 1704.6.1
  - a. THE BOOSTER STATION, CHEMICAL BUILDING, AND WATER TREATMENT BUILDING ARE CLASSIFIED AS RISK CATEGORY III, REQUIRING STRUCTURAL OBSERVATIONS BY A REGISTERED DESIGN PROFESSIONAL.
  - b. THE REGISTERED STRUCTURAL OBSERVER SHALL VISUALLY OBSERVE REPRESENTATIVE LOCATIONS OF STRUCTURAL SYSTEMS, DETAILS AND LOAD PATHS FOR GENERAL CONFORMANCE TO THE APPROVED CONSTRUCTION DOCUMENTS.
7. INSPECTIONS AND TESTS REQUIRED IN CHAPTER 17 DO NOT SUPERSEDE OR MAKE UNNECESSARY INSPECTIONS AND TESTS REQUIRED BY ANY LAW OR REGULATION.

SCALE VERIFICATION	DRAWN BY	CLG	NO.	DATE	INITIALS	REVISION DESCRIPTIONS
BAR IS ONE INCH LONG ON ORIGINAL DRAWING 	CHECKED BY	MAP				
	APPROVED BY	JCB				
	ISSUE DATE	FEBRUARY 2026				
	PROJECT NUMBER	703222-04-001				

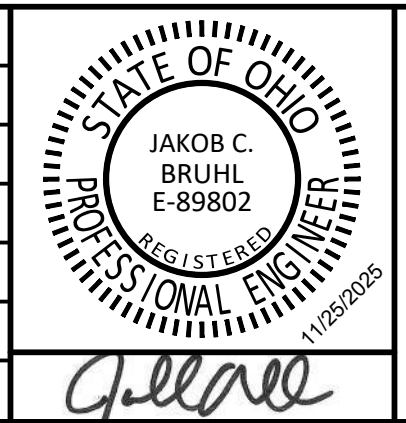

<b>WATER SYSTEM IMPROVEMENTS</b> CONTRACT B NEW BOOSTER STATION AND WATER TREATMENT PLANT IMPROVEMENTS VILLAGE OF HOGDALE, OHIO
<b>STRUCTURAL GENERAL NOTES</b>

SHEET NO.	1S1
PAGE NO.	4
	DDAGW-4113



Drawing: X:\hodge\01703222-Holgate WTP\DWG\Sheets\703222-MD-HVAC.dwg | Plotter: 01/2026 @ 01:54:47 | LastSavedBy: CurieS

For Viewing Purposes Only - Visit [www.wesslerengineering.com](http://www.wesslerengineering.com) to Purchase

**VALVES:**

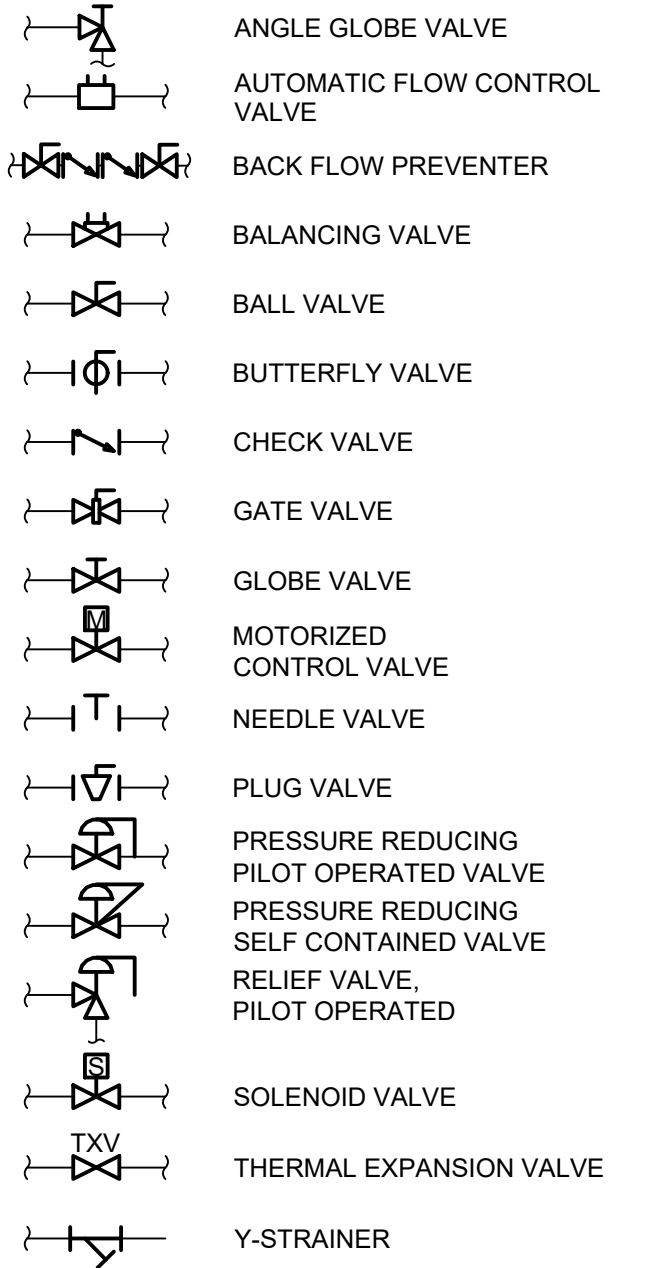

**PIPE AND PIPE FITTINGS:**

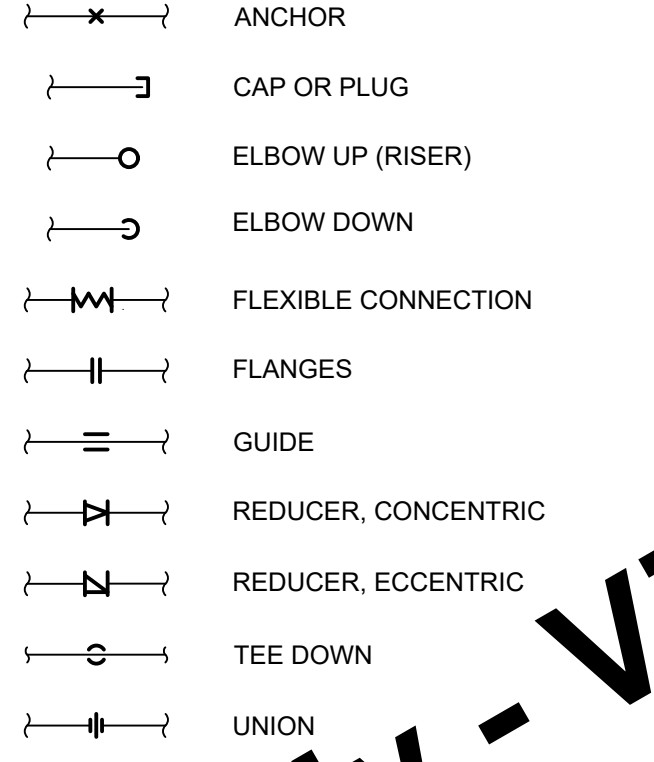

**DUCTWORK:**

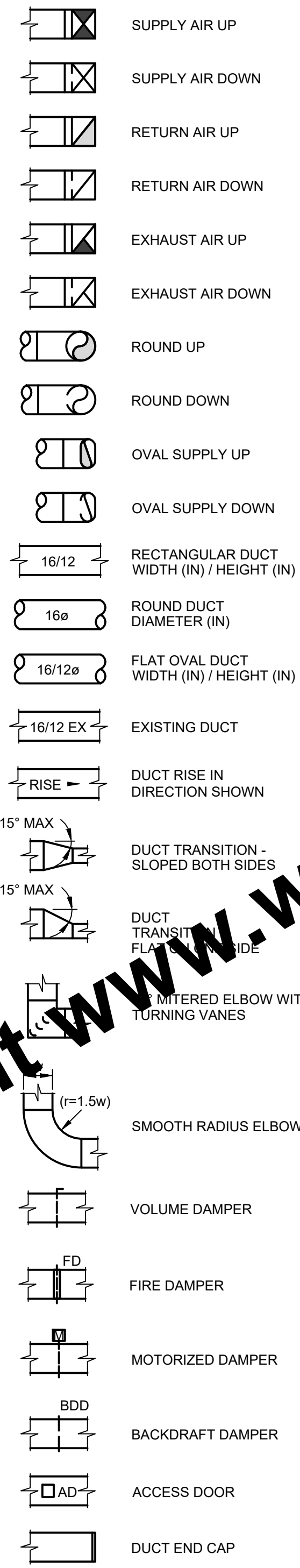

**GENERAL SYMBOLS:**

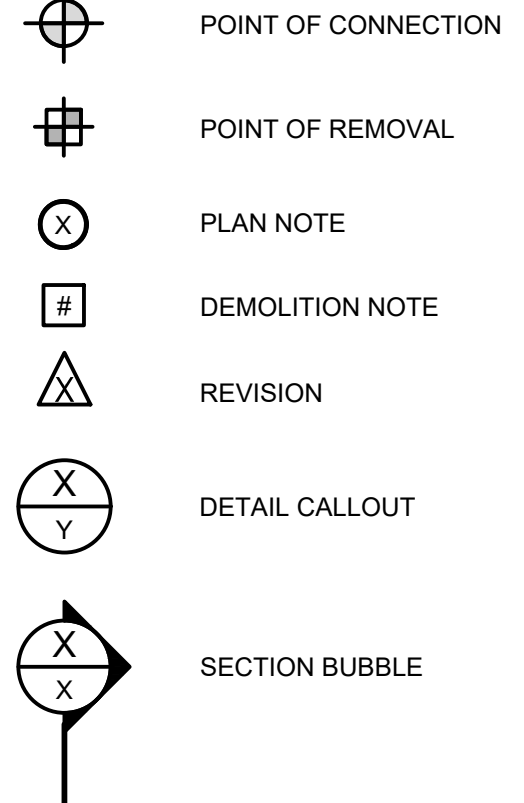

**GRILLES, REGISTERS AND DIFFUSER NOMENCLATURE**

NOTE: UNDERLINED EQUIPMENT TAGS INDICATE ITEM IS SCHEDULED.

**SUPPLY DIFFUSERS:**

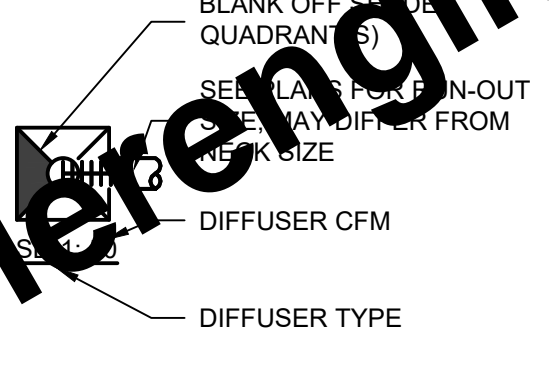

**RETURN (AND EXHAUST) GRILLES:**

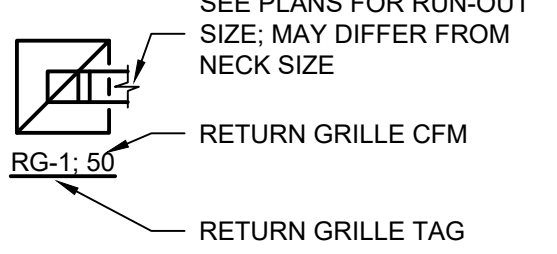

**LINEAR SLOT DIFFUSER:**

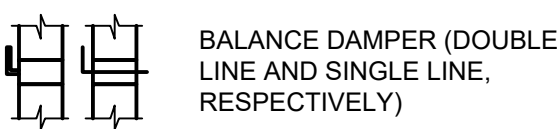
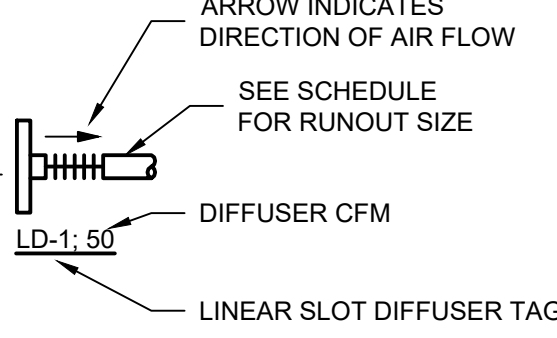

**SENSOR NOMENCLATURE:**

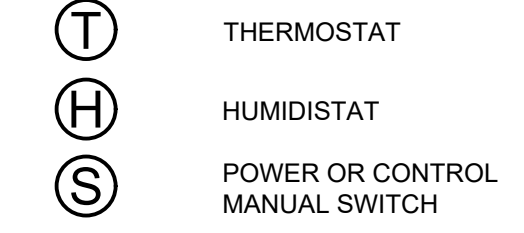

**MECHANICAL ABBREVIATIONS:**

AFF	ABOVE FINISHED FLOOR
AFG	ABOVE FINISHED GRADE
AHU	AIR HANDLING UNIT
AD	ACCESS DOOR
BD	BALANCE DAMPER
BDD	BACKDRAFT DAMPER
BFP	BACKFLOW PREVENTER
BHP	BRAKE HORSEPOWER
BLDG	BUILDING
BOD	BOTTOM OF DUCT
BOS	BOTTOM OF STEEL
BTU	BRITISH THERMAL UNITS
BTUH	BTUS PER HOUR
C	CONDENSATE
CA	COMPRESSED AIR
CD	CONDENSATE DRAIN
CO	CLEANOUT
D	DAMPER
DCW	DOMESTIC COLD WATER
DB	DRY BULB
DIA	DIAMETER
DN	DOWN
DHW	DOMESTIC HOT WATER
DHWR	DOMESTIC HOT WATER RETURN
DWH	DOMESTIC WATER HEATER
EF	EXHAUST FAN
ECRU	EXHAUST RESISTANT EPUH
EG	EXHAUST GRILLE (NO BD)
EP	ELECTRIC PROPELLER UNIT HEATER
ER	EXHAUST REGISTER (WITH INTEGRAL BD)
ERV	ENERGY RECOVERY VENTILATOR
ESP	EXTERNAL STATIC PRESSURE
EWUH	ELECTRIC WALL MOUNTED UNIT HEATER
EX	EXISTING
FD	FIRE DAMPER, FLOOR DRAIN
FDC	FIRE DEPARTMENT CONNECTION
FLA	FULL LOAD AMPS
FOB	FLAT ON BOTTOM
FOT	FLAT ON TOP
GFUH	GAS FIRED UNIT HEATER
HB	HOSE BIBB
HWRP	HOT WATER RECIRCULATION PUMP
IE	INVERT ELEVATION
IN	INCHES
L	LOUVER
LAV	LAVATORY
MB	MOP BASIN
NC	NORMALLY CLOSED
NO	NORMALLY OPEN
PIV	POST INDICATING VALVE
PRV	PRESSURE RELIEF VALVE
PSIA	POUNDS PER SQUARE INCH ABSOLUTE
PSIG	POUNDS PER SQUARE INCH GAUGE
RF	RETURN FAN
RG	RETURN GRILLE (NO BD)
RR	RETURN REGISTER (WITH INTEGRAL BD)
RO	REVERSE OSMOSIS
RPBP	REDUCED PRESSURE BACKFLOW PREVENTER
RIV	ROOF INTAKE VENTILATOR
RRV	ROOF RELIEF VENTILATOR
SAN	SANITARY
SD	SUPPLY DIFFUSER
SG	SUPPLY GRILLE (NO BD)
SR	SUPPLY REGISTER (WITH INTEGRAL BD)
SK	SINK
SSAC	SPLIT SYSTEM AIR CONDITIONER
SSHP	SPLIT SYSTEM HEAT PUMP
TD	TRENCH DRAIN
TG	TRANSFER GRILLE
TMV	THERMOSTATIC MIXING VALVE
TSP	TOTAL STATIC PRESSURE
V	SANITARY VENT
VD	VOLUME DAMPER
VFD	VARIABLE FREQUENCY DRIVE
VTR	VENT THRU ROOF
WB	WET BULB
WC	WATER CLOSET
WHYD	WALL HYDRANT

**GENERAL NOTES:**

- THIS CONTRACT INCLUDES THE PROJECT MANUAL AND ALL RELEVANT SPECIFICATIONS PROVIDED IN THE MANUAL.
- CONTRACTOR SHALL BE FAMILIAR WITH THE WORK SITE AND THE CONTRACT DOCUMENTS PRIOR TO SUBMITTING THEIR BID. SUBSTITUTIONS SHALL BE APPROVED PRIOR TO BID.
- NOTIFY THE ENGINEER OF ANY EXISTING INFORMATION FOUND IN THE CONTRACT DOCUMENTS AS SOON AS POSSIBLE AND PRIOR TO PROCEEDING WITH WORK IN THE VICINITY OR ON THE ABOVE LISTED SYSTEMS.
- CONTRACTOR SHALL CONTACT ALL APPLICABLE PERMITTING AGENCIES WITHIN THE TIME PERIOD SPECIFIED BY THAT AGENCY PRIOR TO THE COMMENCING WITH CONSTRUCTION.
- ALL WORK SHALL COMPLY WITH REQUIREMENTS OF ALL APPLICABLE CODES, LAWS, ORDINANCES AND REGULATIONS OF ALL AUTHORITIES HAVING JURISDICTION. THIS CONTRACTOR SHALL OBTAIN AND PAY FOR ALL PERMITS, FEES, ETC. AND FURNISH SIGNED, CERTIFIED AND ACCEPTABLE COPIES TO THE OWNER FOR HIS RECORD.
- DRAWINGS ARE DIAGRAMMATIC AND SHOW THE GENERAL SCOPE, DESIGN INTENT, ARRANGEMENT, AND GENERAL EXTENT OF SYSTEMS. THIS CONTRACTOR IS RESPONSIBLE FOR FIELD COORDINATING WITH OTHER ALL OTHER TRADES PRIOR TO THE FABRICATION AND ASSEMBLY OF MECHANICAL SYSTEMS.
- ALL MATERIALS AND EQUIPMENT SHALL BE INSTALLED IN ACCORDANCE WITH MANUFACTURER'S WRITTEN REQUIREMENTS.
- ALL EQUIPMENT SHALL BE MAINTAINABLE AND ACCESSIBLE, AND MANUFACTURER'S RECOMMENDED ACCESS SHALL NOT BE OBSTRUCTED BY THE WORK OF ANY TRADE. COORDINATE SYSTEM INSTALLATION PRIOR TO SUBMITTING ASSOCIATED SHOP DRAWINGS.
- CONTRACTOR IS RESPONSIBLE FOR MAINTAINING THE FIRE RATING OF ALL STRUCTURAL AND ARCHITECTURAL WALLS, CEILINGS, ETC. AT ALL PENETRATIONS.
- SOME MATERIALS AND EQUIPMENT MAY BE INSTALLED IN HAZARDOUS AREAS. CONTRACTOR IS RESPONSIBLE FOR ENSURING ALL INSTALLED MATERIALS AND EQUIPMENT COMPLY WITH THE ASSOCIATED HAZARD RATING.
- CONTRACTOR SHALL BE RESPONSIBLE FOR LOCATING AND INSTALLING ALL SLEEVES, INSERTS AND SUPPORTS REQUIRED FOR INSTALLATION OF THE WORK. ALL SUPPORTS FROM STRUCTURE AND ALL WALL, FLOOR AND ROOF PENETRATIONS SHALL BE VERIFIED WITH THE GENERAL CONTRACTOR AND STRUCTURAL ENGINEER PRIOR TO INSTALLATION.
- CONTRACTOR IS RESPONSIBLE FOR THE REPAIR OF ANY DAMAGE THEY CAUSE TO THE FACILITIES OR SITE OF THIS PROJECT.
- CONTRACTOR SHALL DETERMINE FROM THE OWNER IF ANY REMOVED MATERIAL, EQUIPMENT, ETC. IS TO BE TURNED OVER TO THE OWNER.
- CONTRACTOR IS RESPONSIBLE FOR PROVIDING COMPLETE AND OPERABLE SYSTEMS SHOWN ON THE PLANS, INCLUDING TEST AND BALANCE OF EACH WATER AND AIR MOVING SYSTEM.

SCALE VERIFICATION BAR IS ONE INCH LONG ON ORIGINAL DRAWING	DRAWN BY	CLG	NO.	DATE	INITIALS	REVISION DESCRIPTIONS
	CHECKED BY	SPR				
	APPROVED BY	WCM				
	ISSUE DATE	FEBRUARY 2026				
	PROJECT NUMBER	703222-04-001				

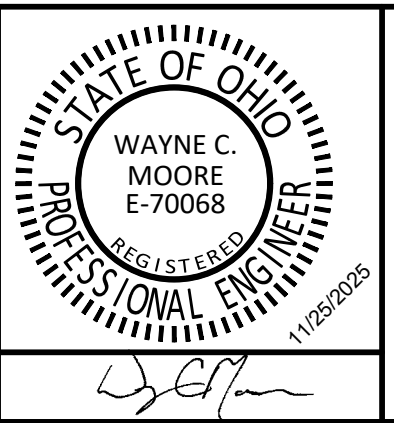

**WATER SYSTEM IMPROVEMENTS**

CONTRACT B NEW BOOSTER STATION AND WATER TREATMENT PLANT IMPROVEMENTS  
VILLAGE OF HOLTGATE, OHIO

**MECHANICAL SYMBOLS AND NOTATION**

SHEET NO.  
**1M1**

PAGE NO.  
**5**

DDAGW-4113

APPROVED Environmental Protection Agency 02/20/2026

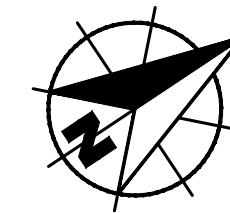



0 5 10 20 FT  
1" = 10'

**GENERAL NOTES:**

1. INSTALL EROSION AND SEDIMENT CONTROL MEASURES AS SHOWN ON THE PLAN SHEETS AND AS NECESSARY TO PROVIDE ADEQUATE CONTROL FOR THE CONSTRUCTION AREA. SEE SPECIFICATION 02101.
2. ACCESS TO THE CONSTRUCTION SITE IS TO BE VERIFIED WITH LOCAL AGENCIES PRIOR TO THE BEGINNING OF CONSTRUCTION.
3. ROADS ARE TO BE MONITORED FOR SEDIMENT TRACKING AND SWEEP AS NEEDED.

**LEGEND**

-  INLET PROTECTION
-  CONCRETE WASHOUT AREA
-  SILT FENCING

**KEYED NOTES**

- 01 DEMOLISH EXISTING WATER TREATMENT PLANT BUILDING. SEE SHEET 2D2
- 02 DEMOLISH EXISTING DETENTION TANK AND AERATOR. SEE SPECIFICATIONS
- 03 ABANDON WELL NO. 1 AND DEMOLISH EXISTING WELL HOUSE. SEE SPECIFICATIONS
- 04 CUT AND CAP EXISTING 6" WATER MAIN
- 05 REMOVE EXISTING GATE VALVE AND BOX
- 06 REMOVE SECTION OF EXISTING WATER MAIN
- 07 DEMOLISH EXISTING CONCRETE PAD, SANITARY MANHOLES AND STORM INLET TO REMAIN
- 08 DEMOLISH EXISTING SITE FENCING AND GATES COMPLETE
- 09 PLUG EXISTING SANITARY LINE AT MANHOLE
- 10 DEMOLISH EXISTING CONCRETE SIDEWALK
- 11 COORDINATE WITH OWNER TO CLOSE VALVE AND CUT AND CAP EXISTING 8" WATER MAIN
- 12 COORDINATE WITH GAS UTILITY TO SHUT OFF AND DEMOLISH EXISTING GAS SERVICE
- 13 EXISTING ELECTRICAL FEED TO HSP BUILDING TO REMAIN IN SERVICE UNTIL BUILDING IS REFERED FROM NEW TREATMENT PLANT BUILDING. SEE SPECIFICATION SECTION 01550



For Viewing Purposes Only - Visit [www.wesslerengineering.com](http://www.wesslerengineering.com) to Purchase

Drawing: X:\Hogate\_OH\703222\Hogate\WTP\Contract B - Booster Station and WTP\DWG\Sheets\703222-EX-WTP.dwg | Layout: 2D1 | Plotfile: 01/20/26 @ 01:29:58 | LastSavedBy: ConisG

<b>SCALE VERIFICATION</b> BAR IS ONE INCH LONG ON ORIGINAL DRAWING 	DRAWN BY	CLG	NO.	DATE	INITIALS	REVISION DESCRIPTIONS
	CHECKED BY	MAP				
	APPROVED BY	AMS				
	ISSUE DATE	FEBRUARY 2026				
	PROJECT NUMBER	703222-04-001				

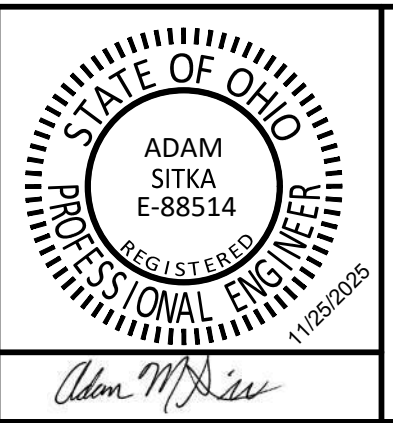

**WATER SYSTEM IMPROVEMENTS**

CONTRACT B NEW BOOSTER STATION AND WATER TREATMENT PLANT IMPROVEMENTS  
VILLAGE OF HOGATE, OHIO

---

**EXISTING WATER TREATMENT PLANT  
DEMOLITION SITE PLAN**

SHEET NO.	<b>2D1</b>
PAGE NO.	<b>6</b>
	DDAGW-4113 02/20/2026

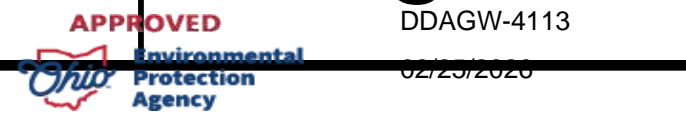



**EXISTING WELL NO. 1 AND AERATOR**  
SCALE: NONE



**EXISTING WATER TREATMENT PLANT BUILDING**  
SCALE: NONE



**EXISTING DETENTION TANK**  
SCALE: NONE



**EXISTING FILTER ROOM**  
SCALE: NONE



**EXISTING LOW SERVICE PUMP ROOM**  
SCALE: NONE

**GENERAL NOTES:**

1. DEMOLISH EXISTING WELLHOUSE COMPLETE INCLUDING BUILDING ROOF, WALLS, FLOOR SLAB, AND FOUNDATIONS. REMOVE ALL PIPING, WELL PUMP AND MOTOR, AND OTHER EQUIPMENT. ABANDON EXISTING WELL NO. 1 IN ACCORDANCE WITH SPECIFICATION 02050.
2. DEMOLISH EXISTING CONCRETE DETENTION TANK COMPLETE INCLUDING ROOF, WALLS, ACCESS HATCHES, AND OTHER EXISTING FEATURES. REFER TO SPECIFICATIONS FOR HISTORIC DRAWINGS OF TANK.
3. DEMOLISH EXISTING WATER TREATMENT PLANT BUILDING COMPLETE INCLUDING ALL ROOF, WALLS, FLOOR SLAB AND FOUNDATIONS. REFER TO SPECIFICATIONS FOR LEAD AND ASBESTOS TESTING RESULTS.
4. DEMOLISH ALL WATER TREATMENT EQUIPMENT INCLUDING BUT NOT LIMITED TO ALL PROCESS PIPING, PUMPS AND MOTORS, FILTERS, ELECTRICAL EQUIPMENT, TELEMTRY EQUIPMENT, AND MISCELLANEOUS OFFICE EQUIPMENT.
5. SALVAGE AND RELOCATE CHLORINE ANALYZER TO NEW WATER TREATMENT BUILDING. REFER TO SPECIFICATION 02050 FOR COMPLETE SALVAGE LIST.

For Viewing Purposes Only - Visit [www.wesslerengineering.com](http://www.wesslerengineering.com) to Purchase

Drawing: X:\Hogate\_OH\703222\_Hogate\_WTP\Contract B - Booster Station and WTP\DWG Sheets\703222-04-001-EX-WTP.dwg | Layout: 202 | Plotter: 01/20/26 @ 01:43:49 | LastSavedBy: ConisG

<p style="text-align: center; font-weight: bold;">NOTICE!</p> <p style="text-align: center; font-weight: bold;">PRINT SHEET IN COLOR</p> <p style="font-size: 0.8em;">THIS SHEET WAS CREATED WITH COLOR LINEWORK, SHADING AND/OR PHOTOS, AND MUST BE PRINTED IN COLOR FOR IMPROVEMENTS TO BE CLEARLY VISIBLE.</p>	SCALE VERIFICATION	DRAWN BY	CLG	NO.	DATE	INITIALS	REVISION DESCRIPTIONS			WATER SYSTEM IMPROVEMENTS	SHEET NO.
	BAR IS ONE INCH LONG ON ORIGINAL DRAWING	CHECKED BY	MAP							2D2	
		APPROVED BY	AMS							PAGE NO.	
		ISSUE DATE	FEBRUARY 2026							7	
		PROJECT NUMBER	703222-04-001							DDAGW-4113	
							EXISTING WATER TREATMENT PLANT DEMOLITION NOTES	02/20/2026			



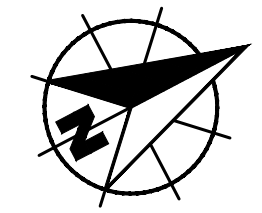

0 5 10 20 FT  
1" = 10'

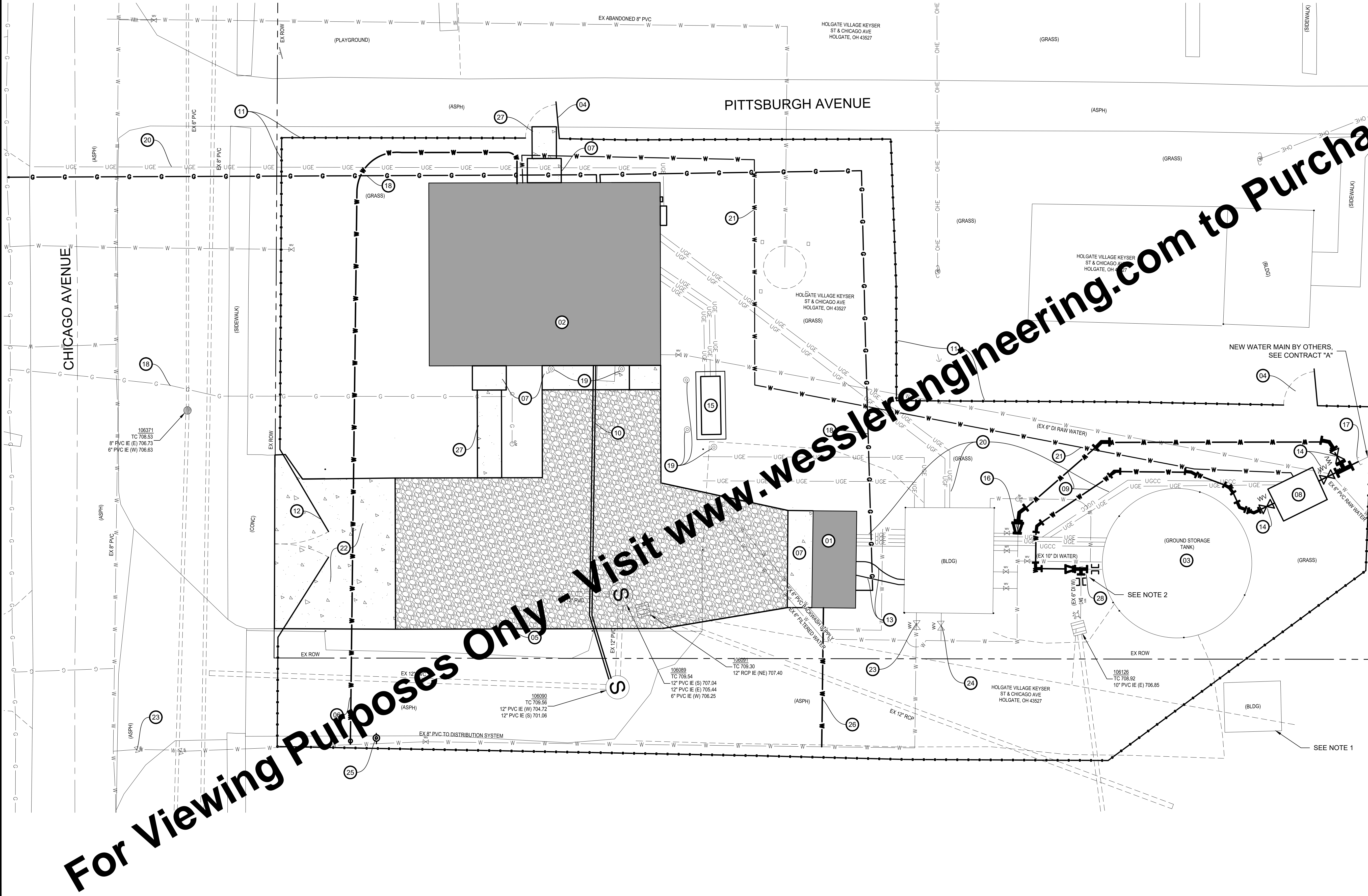

**GENERAL NOTES:**

- EXISTING CONCESSION STAND TO BE REMOVED BY OWNER PRIOR TO CONSTRUCTION.
- EXPOSE EXISTING 6" MAIN. ENSURE EVERY JOINT IS RESTRAINED. IF NOT RESTRAINED, ADD JOINT OR FITTING RESTRAINT AT EACH EXISTING JOINT.

**KEYED NOTES ○**

- NEW CHEMICAL BUILDING. SEE AREA 03
- NEW WATER TREATMENT BUILDING. SEE AREA 04
- GROUND STORAGE TANK IMPROVEMENTS. SEE AREA 05
- NEW PEDESTRIAN SWING GATE. SEE DETAIL SHEET 7MD1
- NEW CRUSHED STONE ACCESS DRIVE. SEE DETAIL SHEET 7MD2
- NEW 1 1/2" HDPE WATER SERVICE LINE
- NEW CONCRETE STOOP
- NEW METER AND VALVE VAULT. SEE DETAIL SHEET 5C1
- NEW 8" DUCTILE IRON WATER MAIN
- NEW 6" PVC BUILDING SANITARY SEWER WITH MINIMUM 1% SLOPE AND CONNECT TO EXISTING MANHOLE. SEE DETAIL SHEET 7MD3
- NEW GALVANIZED CHAIN LINK FENCE. SEE DETAIL SHEET 7MD1
- NEW ACCESS GATE. SEE DETAIL SHEET 7MD1
- NEW BURIED CHEMICAL LINES. SEE AREA 03
- NEW 8" MJ GATE VALVE AND BOX
- NEW GENERATOR AND CONCRETE PAD. SEE ELECTRICAL SHEETS
- REMOVE CAP/PLUG AND CONNECT TO EXISTING 10" X 8" TEE WITH 10" X 8" MJ REDUCER
- REMOVE CAP AND CONNECT TO NEW WATER MAIN BY OTHERS
- COORDINATE WITH GAS UTILITY FOR NEW GAS SERVICE TO NEW WATER TREATMENT BUILDING AND NEW CHEMICAL BUILDING
- NEW BOLLARDS. SEE DETAIL SHEET 7MD3
- NEW ELECTRICAL LINES. SEE ELECTRICAL SHEET 2E1
- NEW 1/2" HDPE PRE-TREATMENT WATER SAMPLE LINE
- NEW CONCRETE ACCESS DRIVE. SEE DETAIL SHEET 7MD2
- REPLACE EXISTING 8" VALVE
- REPLACE EXISTING 6" VALVE
- NEW ASSE 1057-2023 FREEZE RESISTANT SANITARY YARD HYDRANT WITH BACKFLOW PREVENTION. SEE DETAIL SHEET 7MD1
- NEW 1" HDPE WATER SUPPLY TO CHEMICAL BUILDING
- NEW 5' CONCRETE SIDEWALK
- CUT OUT EXISTING 6" 90° BEND. NEW 6" X 6" MJ TEE, 6" X 8" MJ REDUCER AND (2) 6" MJ SLEEVES. SEE SHEET 5C1.

For Viewing Purposes Only - Visit [www.wesslerengineering.com](http://www.wesslerengineering.com) to Purchase

Vertical text on the left edge: Drawing: X:\Hogate\_Oh\703222\_Hogate\_WTP\Contract B - Booster Station and WTP\DWG\Sheets\703222-NEW-HTR.dwg | Layout: 2Y1 | Plotter: 0128226 @ 08:55:15 | LastSavedBy: Curtiss

SCALE VERIFICATION BAR IS ONE INCH LONG ON ORIGINAL DRAWING 	DRAWN BY	CLG	NO.	DATE	INITIALS	REVISION DESCRIPTIONS
	CHECKED BY	MAP				
	APPROVED BY	AMS				
	ISSUE DATE	FEBRUARY 2026				
	PROJECT NUMBER	703222-04-001				

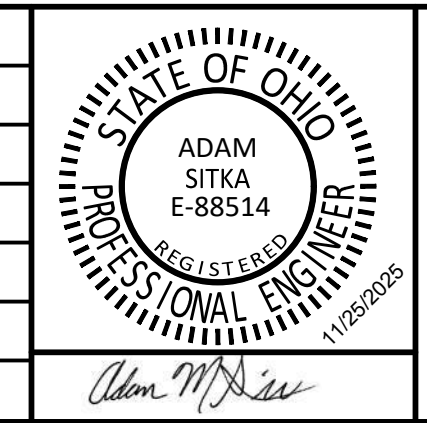

**WATER SYSTEM IMPROVEMENTS**  
 CONTRACT B NEW BOOSTER STATION AND WATER TREATMENT PLANT IMPROVEMENTS  
 VILLAGE OF HOGGATE, OHIO

**EXISTING WATER TREATMENT PLANT  
 SITE IMPROVEMENTS PLAN**

SHEET NO.  
**2Y1**

PAGE NO.  
**8**

DDAGW-4113  
02/23/2026



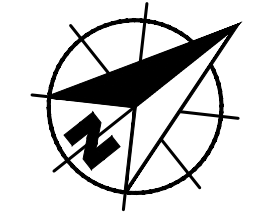

0 5 10 20 FT  
1" = 10'

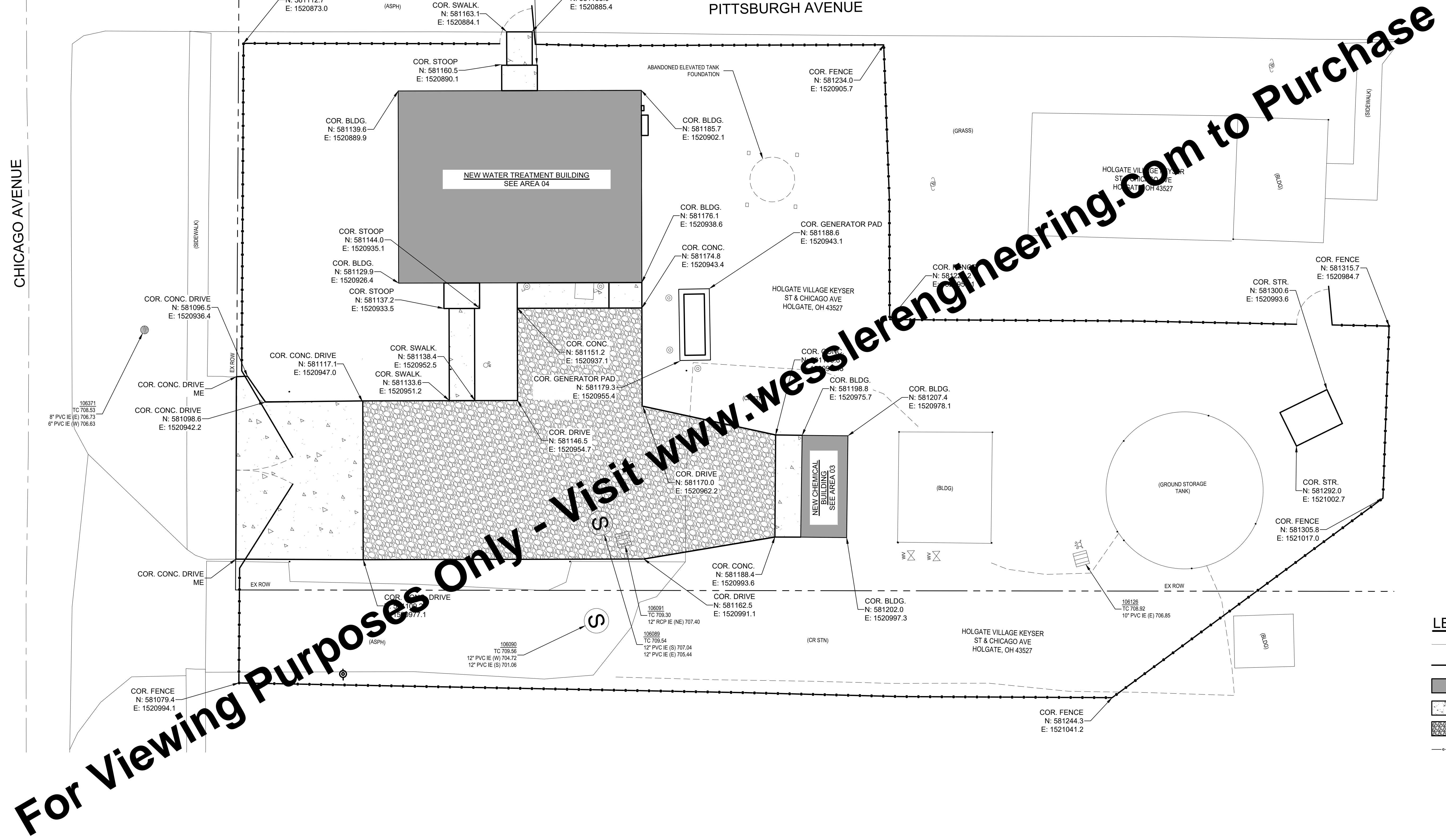

For Viewing Purposes Only - Visit [www.wesslerengineering.com](http://www.wesslerengineering.com) to Purchase

**LEGEND**

- EXISTING FEATURES
- NEW FEATURES
- NEW STRUCTURES
- NEW CONCRETE DRIVE  
SIDEWALK
- NEW CRUSHED STONE DRIVE
- NEW CHAINLINK FENCING

Drawing: X:\Hogate\_OH\703222\_Hogate WTP\Contract B - Booster Station and WTP\DWG Sheets\703222-PN-SC-WTP.dwg | Layout: 2Y2 | Plotted: 01/22/26 @ 09:18:53 | Last Saved By: Curtis G

SCALE VERIFICATION BAR IS ONE INCH LONG ON ORIGINAL DRAWING	DRAWN BY	CLG	NO.	DATE	INITIALS	REVISION DESCRIPTIONS
	CHECKED BY	MAP				
	APPROVED BY	AMS				
	ISSUE DATE	FEBRUARY 2026				
	PROJECT NUMBER	703222-04-001				

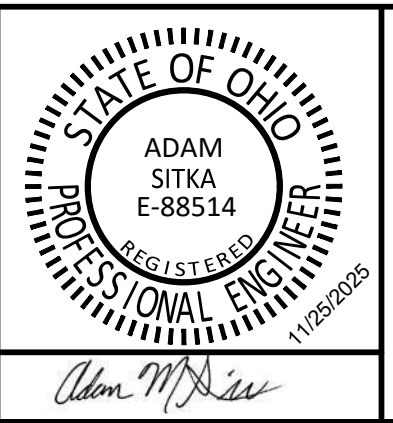

<b>WATER SYSTEM IMPROVEMENTS</b>
CONTRACT B NEW BOOSTER STATION AND WATER TREATMENT PLANT IMPROVEMENTS VILLAGE OF HOLGATE, OHIO
<b>EXISTING WATER TREATMENT PLANT SITE GEOMETRY PLAN</b>

SHEET NO. <b>2Y2</b>
PAGE NO. <b>9</b>
DDAGW-4113 02/20/2026

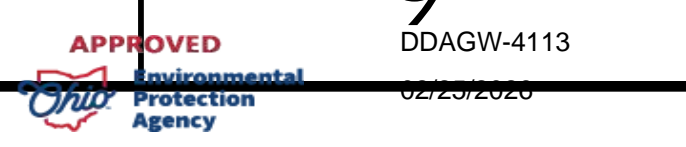

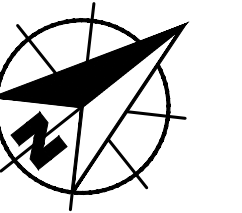

0 5 10 20 FT  
1" = 10'

**GENERAL NOTES:**

1. INSTALL EROSION AND SEDIMENT CONTROL MEASURES AS SHOWN ON THE PLAN SHEETS AND AS NECESSARY TO PROVIDE ADEQUATE CONTROL FOR THE CONSTRUCTION AREA. SEE SPECIFICATION 02101.
2. ACCESS TO THE CONSTRUCTION SITE IS TO BE VERIFIED WITH LOCAL AGENCIES PRIOR TO THE BEGINNING OF CONSTRUCTION. ROADS ARE TO BE MONITORED FOR SEDIMENT TRACKING AND SWEEP AS NEEDED.

**GRADING NOTE:**

1. ALL SLOPES PROVIDED ARE APPROXIMATE. HOLD SPOT ELEVATIONS TO DEVELOP SITE GRADING.
2. GRADE ADJACENT TO THE TANK SHOULD BE 6" BELOW TO TOP OF THE EXISTING CONCRETE PAD

**LEGEND**

- INLET PROTECTION
- CONCRETE WASHOUT AREA
- SILT FENCING
- EXISTING FEATURES
- NEW FEATURES
- NEW STRUCTURES
- NEW CONCRETE DRIVE/SIDEWALK
- NEW CRUSHED STONE DRIVE
- NEW CHAINLINK FENCING
- EXISTING CONTOURS
- PROPOSED CONTOURS

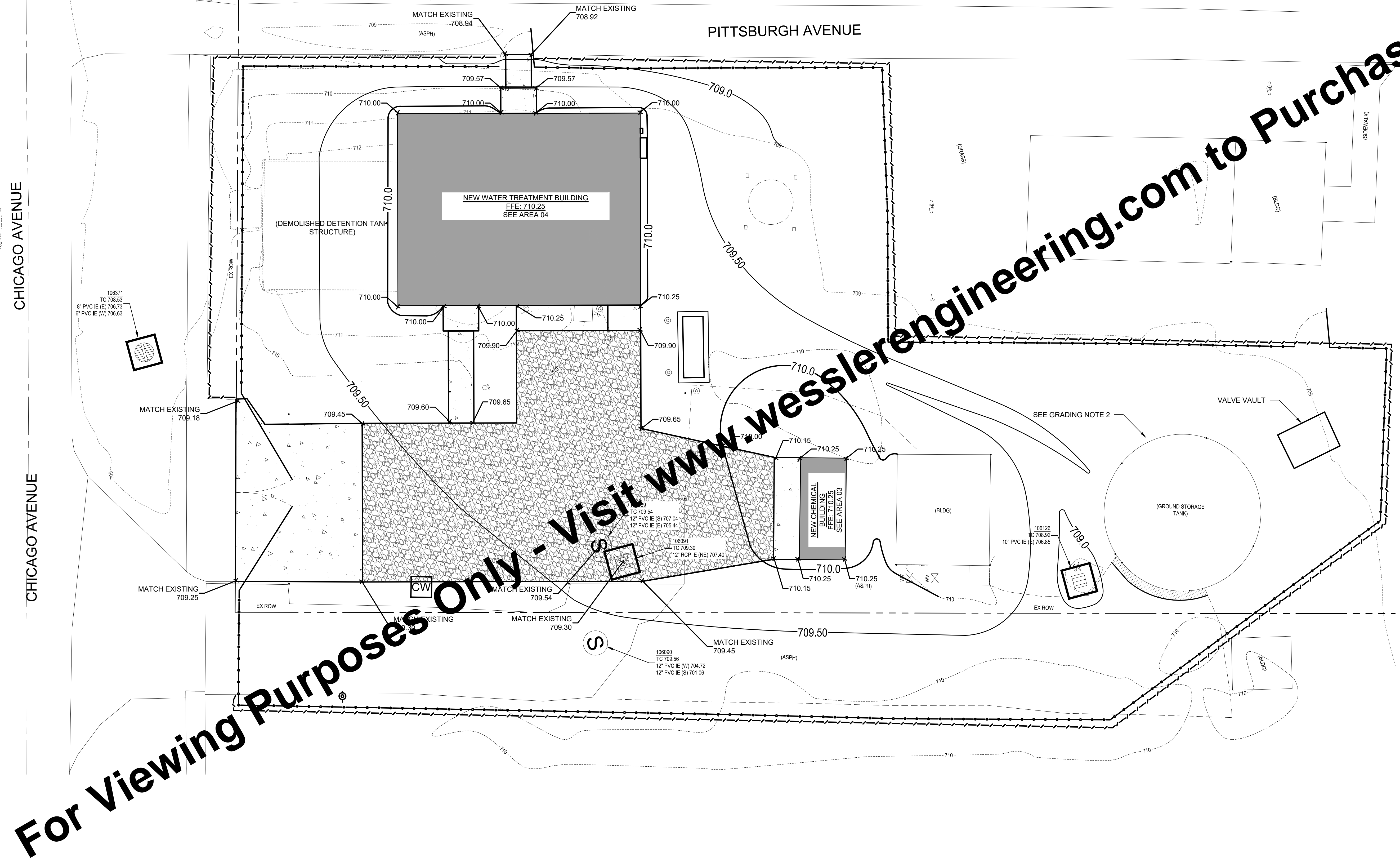

For Viewing Purposes Only - Visit [www.wesslerengineering.com](http://www.wesslerengineering.com) to Purchase

SCALE VERIFICATION	DRAWN BY	CLG	NO.	DATE	INITIALS	REVISION DESCRIPTIONS
BAR IS ONE INCH LONG ON ORIGINAL DRAWING 	CHECKED BY	MAP				
	APPROVED BY	AMS				
	ISSUE DATE	FEBRUARY 2026				
	PROJECT NUMBER	703222-04-001				

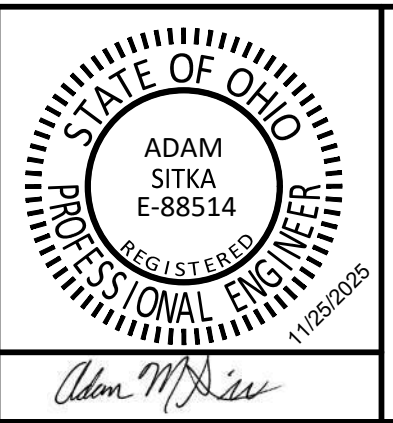

**WATER SYSTEM IMPROVEMENTS**  
 CONTRACT B NEW BOOSTER STATION AND WATER TREATMENT PLANT IMPROVEMENTS  
 VILLAGE OF HOLGATE, OHIO

**EXISTING WATER TREATMENT PLANT  
 GRADING AND EROSION CONTROL PLAN**

SHEET NO.  
**2Y3**

PAGE NO.  
**10**

DDAGW-4113  
02/23/2026



Drawing: X:\Holgeatle\_Ohio\703222\_Holgeatle\_WTP\DWG\Sheets\703222-PN-CR-AWG | Layout: 2Y3 | Plotlet: 01/20/26 @ 01:49:23 | LastSavedBy: CortisG

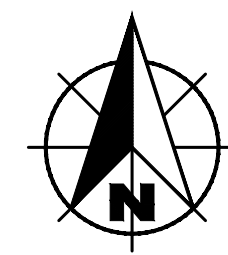

0 5 10 20 FT  
1" = 10'

GENERAL NOTES:  
1. BOOSTER STATION SHALL BE A MIN. OF 90' SETBACK FROM CL OF COUNTRY RD. 14

- KEYED NOTES** ○
- 01 NEW BOOSTER STATION, SEE AREA 06
  - 02 NEW CRUSHED STONE ACCESS DRIVE, SEE DETAIL SHEET 7MD2
  - 03 NEW 8" DUCTILE IRON WATER MAIN
  - 04 REMOVE CAP AND CONNECT TO EXISTING WATER MAINS BY OTHERS, SEE CONTRACT A
  - 05 NEW GALVANIZED CHAIN LINK FENCE (APPROX. 345 LF), SEE DETAIL SHEET 7MD1
  - 06 NEW ACCESS GATE, SEE DETAIL SHEET 7MD1
  - 07 NEW GENERATOR AND CONCRETE PAD, SEE ELECTRICAL SHEETS
  - 08 NEW CONCRETE STOOP, SEE DETAIL SHEET 7MD2
  - 09 NEW TYPE 1 BOLLARDS, SEE DETAIL SHEET 7MD3
  - 10 NEW ELECTRICAL EQUIPMENT, SEE ELECTRICAL SHEETS
  - 11 NEW MECHANICAL EQUIPMENT AND CONCRETE PAD, SEE MECHANICAL SHEETS
  - 12 NEW ELECTRICAL SERVICE, SEE 2E1

**LEGEND**

- EXISTING FEATURES
- NEW FEATURES
- NEW STRUCTURES
- ▨ NEW CONCRETE DRIVE SIDEWALK
- ▩ NEW CRUSHED STONE DRIVE
- NEW CHAINLINK FENCING

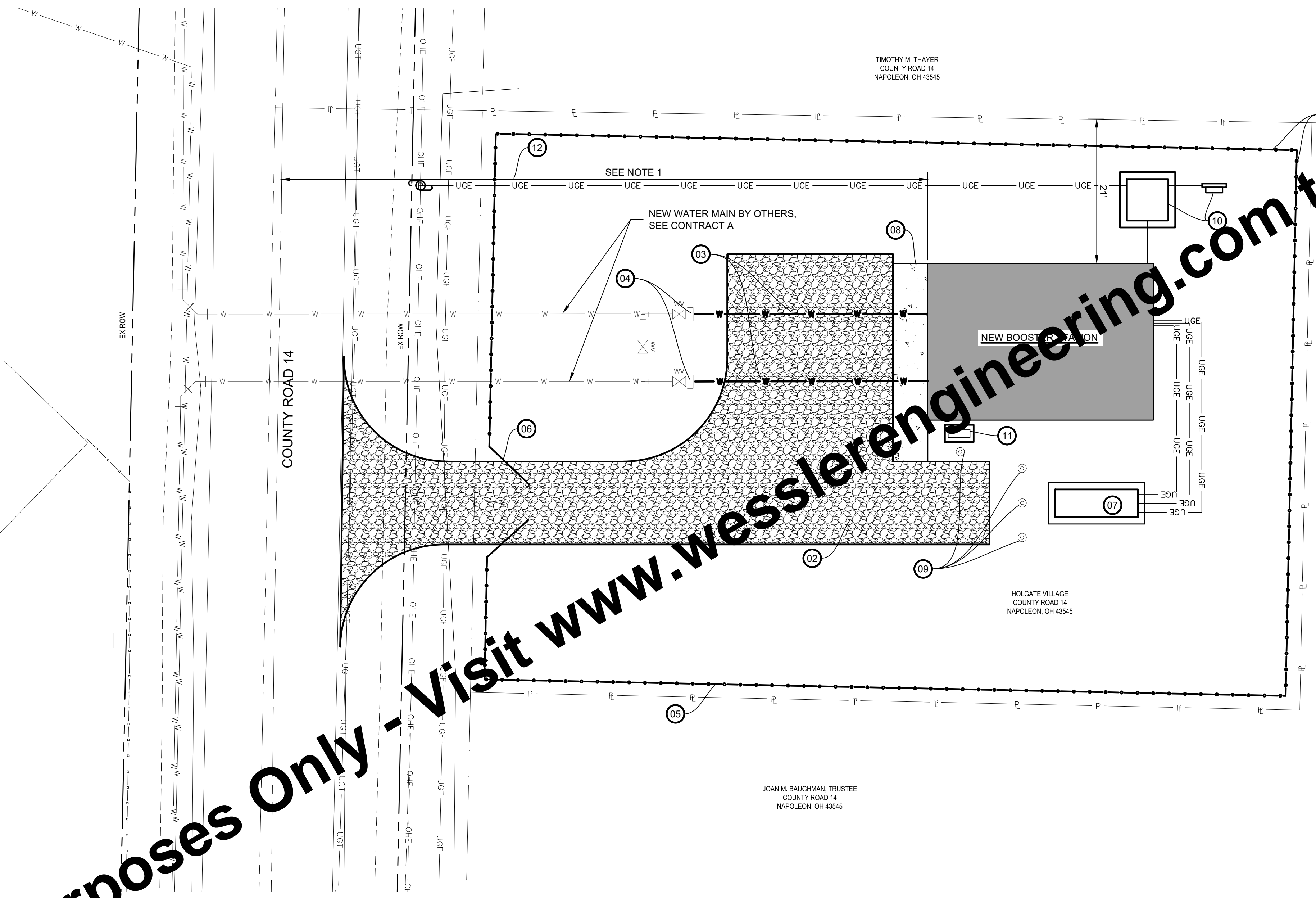

For Viewing Purposes Only - Visit [www.wesslerengineering.com](http://www.wesslerengineering.com) to Purchase

Drawing: X:\Hogdale\_Oh\703222\_Hogdale\WTP\Contract B - Booster Station and WTP\DWG\Sheets\703222-SHNEW-BS.dwg | Layout: 214 | Plotfile: 01/20/26 @ 01:51:17 | LastSavedBy: CmsiG

SCALE VERIFICATION	DRAWN BY	CLG	NO.	DATE	INITIALS	REVISION DESCRIPTIONS
BAR IS ONE INCH LONG ON ORIGINAL DRAWING 	CHECKED BY	MAP				
	APPROVED BY	AMS				
	ISSUE DATE	FEBRUARY 2026				
	PROJECT NUMBER	703222-04-001				

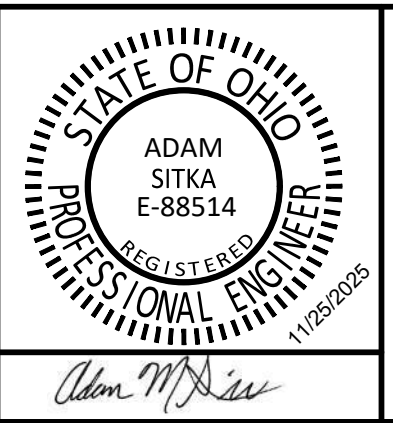

**WATER SYSTEM IMPROVEMENTS**  
 CONTRACT B NEW BOOSTER STATION AND WATER TREATMENT PLANT IMPROVEMENTS  
 VILLAGE OF HOGDALE, OHIO

**NEW BOOSTER STATION  
 SITE IMPROVEMENTS PLAN**

SHEET NO.  
**2Y4**

PAGE NO.  
**11**

DDAGW-4113  
02/20/2026

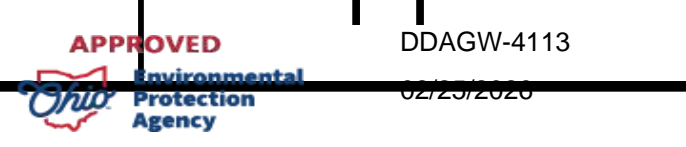



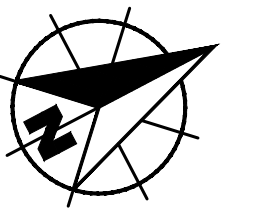

0 5 10 20 FT  
1" = 10'

**GENERAL NOTES:**

1. SEE AREA 08 DRAWINGS FOR ONE LINE DIAGRAMS AND EXACT CONDUIT/WIRE SIZES AND QUANTITIES.

**KEYED NOTES ○**

- 01 NEW CHEMICAL BUILDING, SEE AREA 03
- 02 WATER TREATMENT BUILDING, SEE AREA 04
- 03 GROUND STORAGE TANK IMPROVEMENTS, SEE AREA 05
- 04 EXISTING HSP BUILDING, SEE AREA 03
- 05 UNDERGROUND POWER AND CONTROLS BETWEEN WATER TREATMENT BUILDING AND HSP BUILDING. SEE AREA 08 ONE LINE DIAGRAMS.
- 06 UNDERGROUND POWER AND CONTROLS BETWEEN WATER TREATMENT BUILDING AND GENERATOR. SEE AREA 08 FOR ONE LINE DIAGRAMS.
- 07 NEW UTILITY METERING EQUIPMENT. CONTRACTOR TO COORDINATE WITH UTILITY FOR REQUIRED EQUIPMENT AND LOCATION.
- 08 NEW ELECTRICAL UTILITY SERVICE. CONTRACTOR TO COORDINATE WITH UTILITY ON ROUTING. CONTRACTOR TO PROVIDE 4" C. UTILITY TO PROVIDE WIRE.
- 09 UNDERGROUND POWER AND CONTROLS BETWEEN EXISTING HSP BUILDING AND NEW CHEMICAL BUILDING. SEE AREA 08 FOR ONE LINE DIAGRAMS.
- 10 NEW GENERATOR ON CONCRETE PAD, SEE DETAIL SHEET 8E6
- 11 NEW METER AND VALVE VAULT, SEE AREA 05
- 12 UNDERGROUND POWER AND CONTROLS BETWEEN EXISTING HSP BUILDING AND EXISTING METER AND VALVE VAULT. SEE AREA 05 AND AREA 08 FOR ONE LINE DIAGRAMS.
- 13 UNDERGROUND POWER AND CONTROLS BETWEEN EXISTING HSP BUILDING AND EXISTING GROUND STORAGE TANK. SEE AREA 05 AND AREA 08 FOR ONE LINE DIAGRAMS AND CONDUIT SIZES AND QUANTITIES.

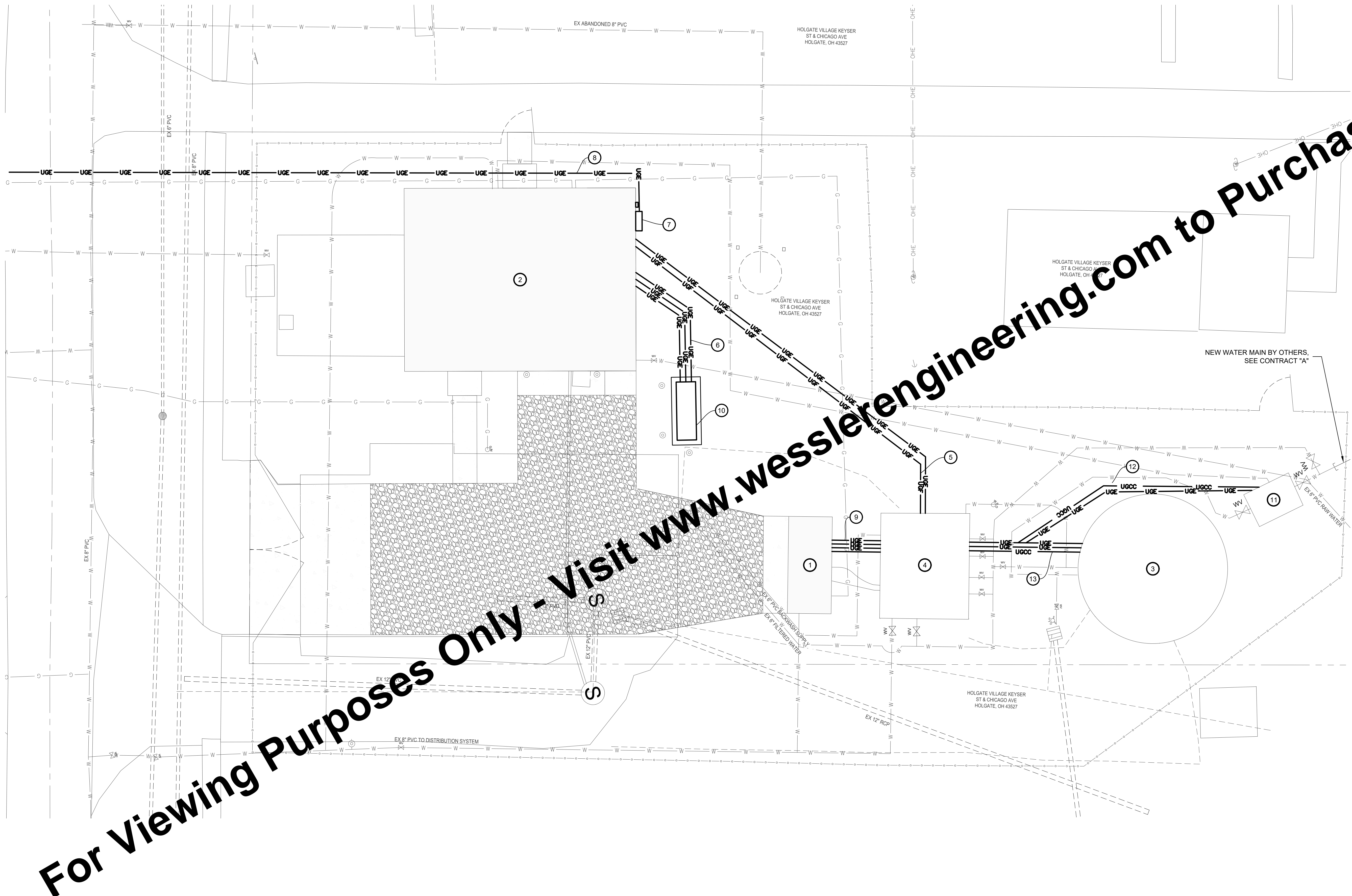

For Viewing Purposes Only - Visit [www.wesslerengineering.com](http://www.wesslerengineering.com) to Purchase

Drawing: X:\Holgeatle\_OH\703222\Holgeatle WTP\Contract B - Booster Station and WTP\DWG\Sheets\703222-04-NEW-HTR.dwg | Layout: 2E1 | Plotter: D20926 @ 03/14/14 | LastSavedBy: CurtBS

SCALE VERIFICATION BAR IS ONE INCH LONG ON ORIGINAL DRAWING 	DRAWN BY	JLK	NO.	DATE	INITIALS	REVISION DESCRIPTIONS
	CHECKED BY	JAP				
	APPROVED BY	WCM				
	ISSUE DATE	FEBRUARY 2026				
	PROJECT NUMBER	703222-04-001				

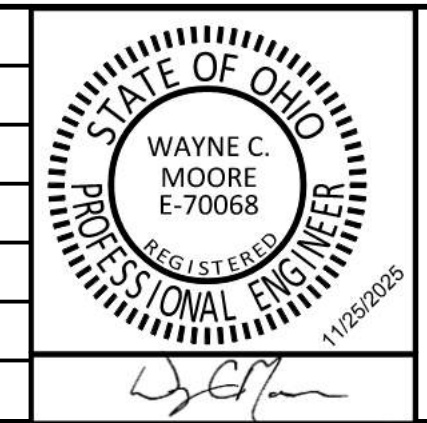

**WATER SYSTEM IMPROVEMENTS**  
 CONTRACT B NEW BOOSTER STATION AND WATER TREATMENT PLANT IMPROVEMENTS  
 VILLAGE OF HOLGATE, OHIO

**EXISTING WATER TREATMENT PLANT  
 ELECTRICAL SITE PLAN**

SHEET NO.	<b>2E1</b>
PAGE NO.	<b>13</b>
DDAGW-4113	

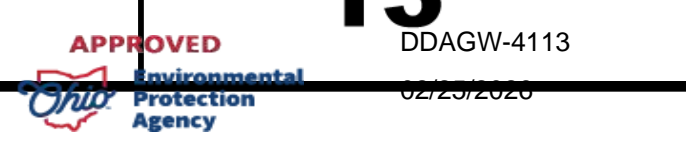

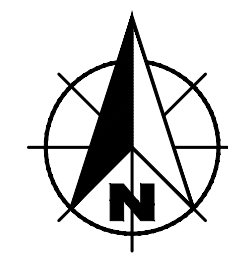

0 5 10 20 FT  
1" = 10'

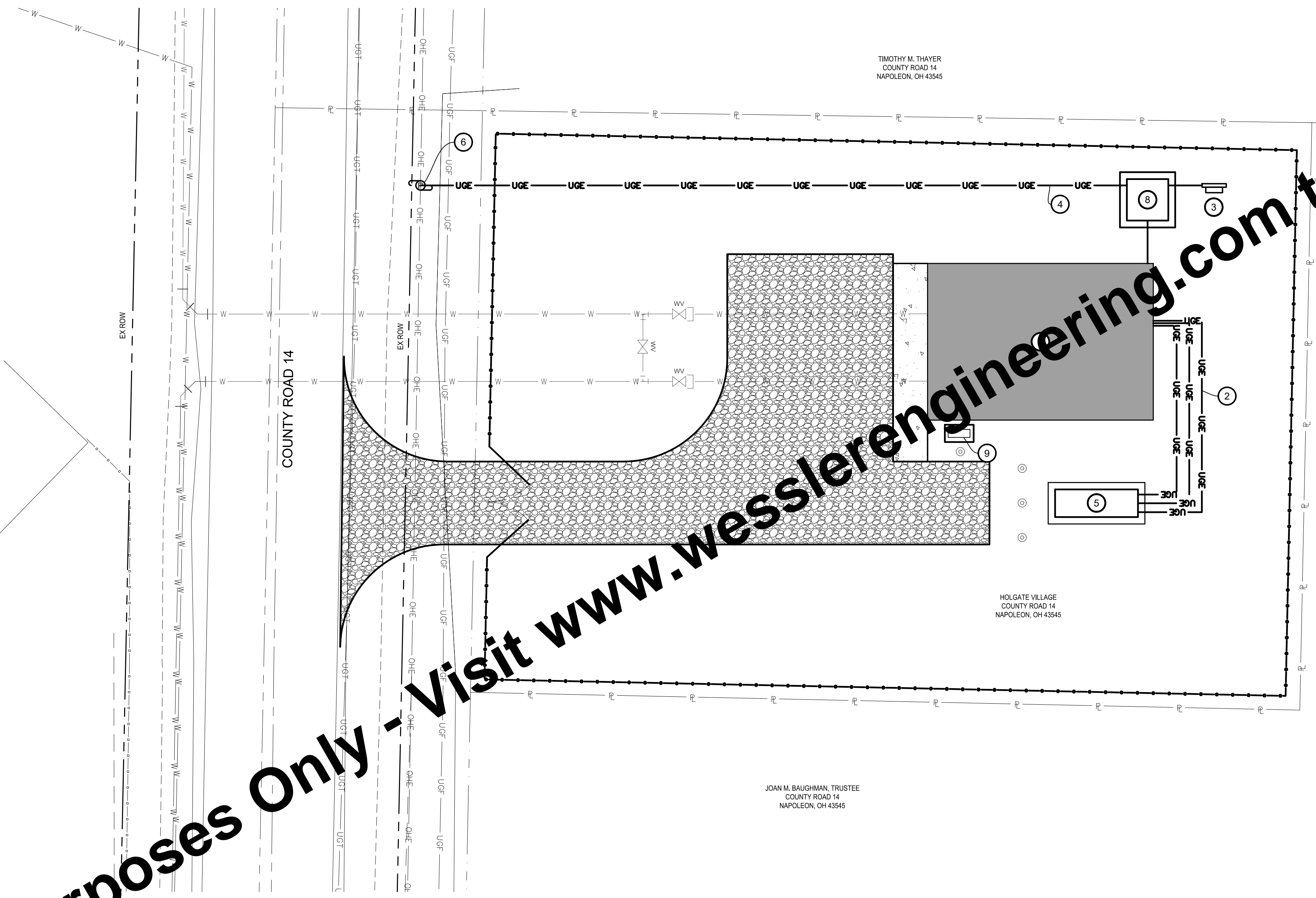

**GENERAL NOTES:**

- SEE AREA 08 DRAWINGS FOR ONE LINE DIAGRAMS AND EXACT CONDUIT/WIRE SIZES AND QUANTITIES.

**KEYED NOTES ○**

- NEW BOOSTER STATION. SEE AREA 06
- UNDERGROUND POWER AND CONTROLS BETWEEN BOOSTER STATION AND GENERATOR. SEE AREA 08 FOR ONE LINE DIAGRAMS.
- NEW UTILITY METERING EQUIPMENT PROVIDED BY UTILITY. CONTRACTOR TO INSTALL METER BASE AND UTILITY WILL PROVIDE AND INSTALL METER.
- NEW ELECTRICAL UTILITY SERVICE. CONTRACTOR TO COORDINATE WITH UTILITY ON ROUTING. CONTRACTOR TO INSTALL 4" C. UTILITY TO PROVIDE WIRE.
- NEW GENERATOR ON CONCRETE PAD.
- NEW POLE BY UTILITY. INSTALL CONDUIT TO POLE AS REQUIRED BY UTILITY.
- INCOMING UTILITY 480/277V UTILITY SERVICE TO BOOSTER STATION. CONDUIT AND WIRE BY CONTRACTOR.
- NEW TRANSFORMER AND TRANSFORMER PAD - BOTH PROVIDED BY UTILITY. CONTRACTOR TO INSTALL TRANSFORMER PAD.
- NEW HVAC EQUIPMENT. SEE SHEET 06E1 FOR POWER REQUIREMENTS.

For Viewing Purposes Only - Visit [www.wesslerengineering.com](http://www.wesslerengineering.com) to Purchase

Drawing: X:\Holgate\_OH\703222\_Holgate WTP\Contract B - Booster Station and WTP\DWG\Sheets\703222-SHNEW-BS.dwg | Layout: 2E2 | Plot: 01/20/26 @ 01:51:48 | LastSavedBy: ChrisG

SCALE VERIFICATION	DRAWN BY	CLG	NO.	DATE	INITIALS	REVISION DESCRIPTIONS
BAR IS ONE INCH LONG ON ORIGINAL DRAWING 	CHECKED BY	MAP				
	APPROVED BY	AMS				
	ISSUE DATE	FEBRUARY 2026				
	PROJECT NUMBER	703222-04-001				

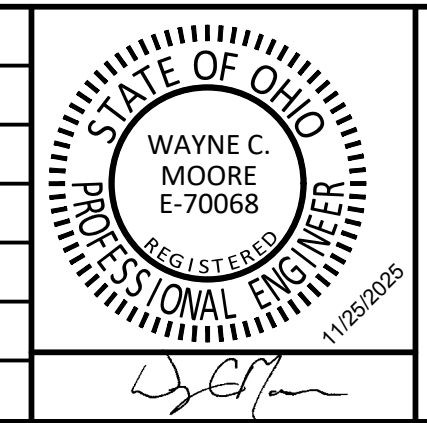

**WATER SYSTEM IMPROVEMENTS**

CONTRACT B NEW BOOSTER STATION AND WATER TREATMENT PLANT IMPROVEMENTS  
VILLAGE OF HOLGATE, OHIO

---

**NEW BOOSTER STATION  
ELECTRICAL SITE PLAN**

SHEET NO. <b>2E2</b>
PAGE NO. <b>14</b>
DDAGW-4113 02/20/2026

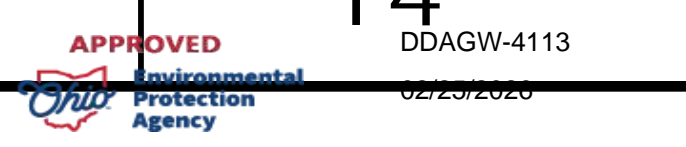

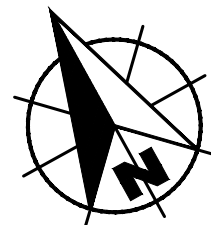

0 1 2 4 FT  
1/2"=1'-0"

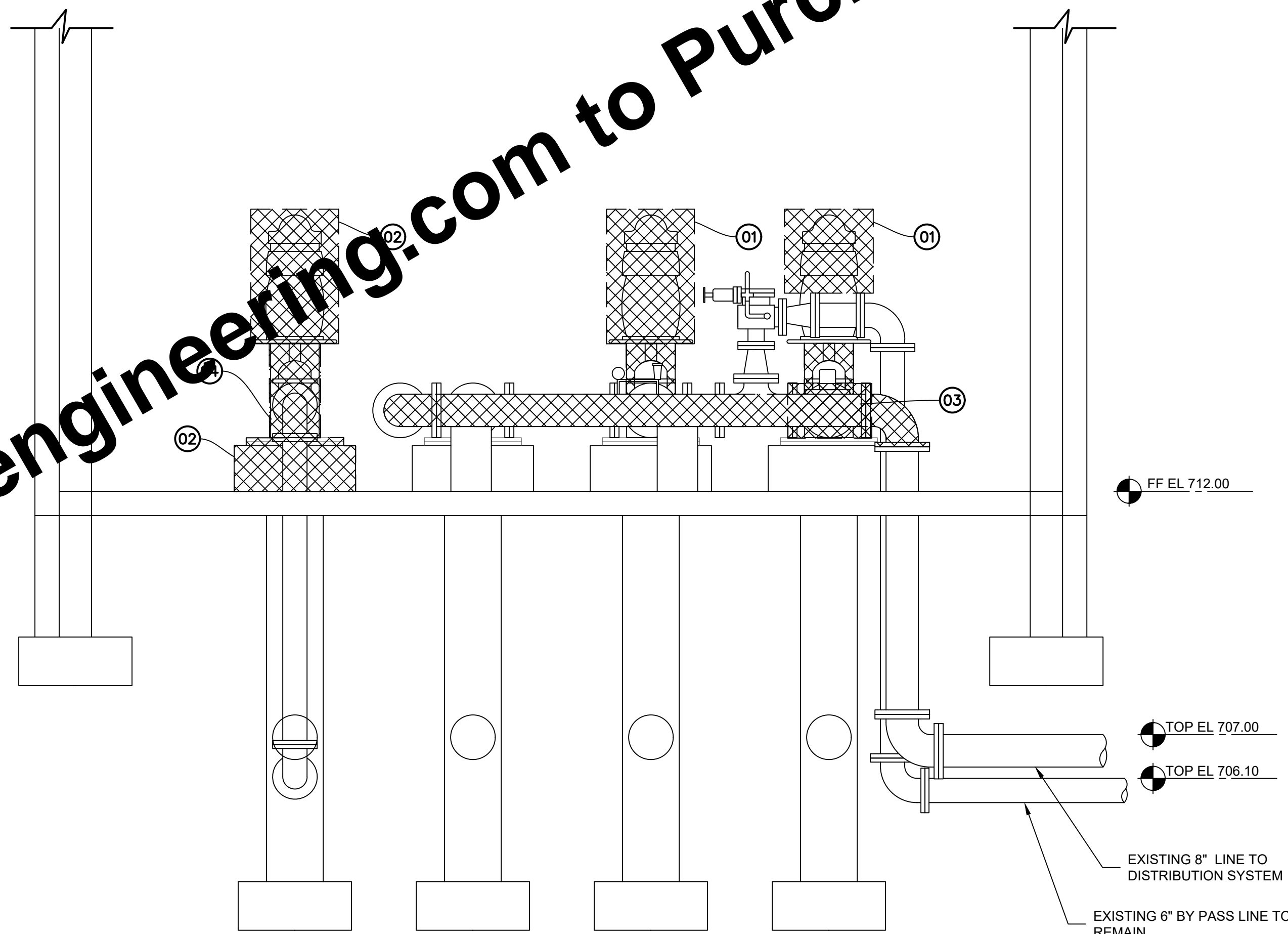
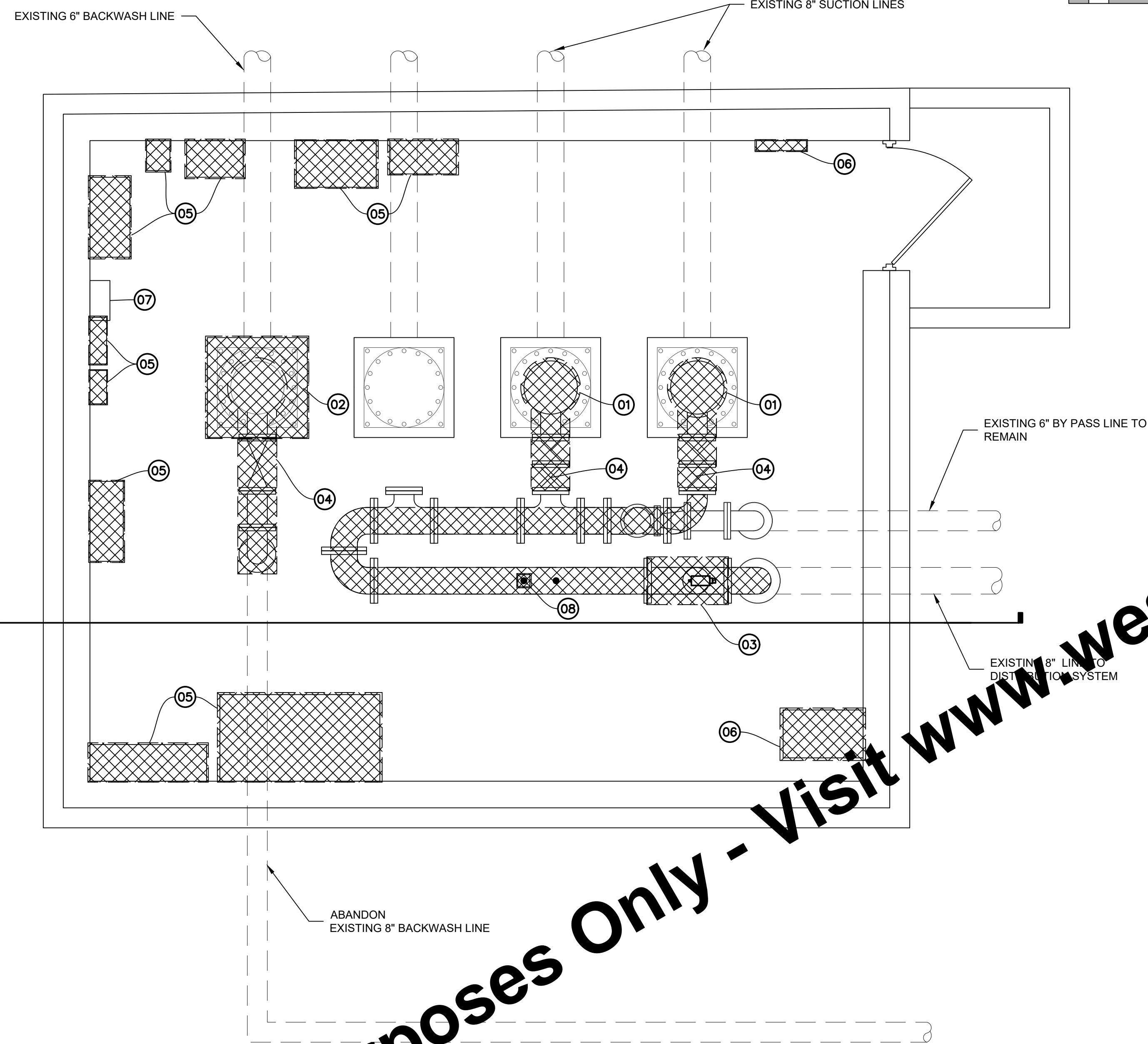

- KEYED NOTES**
- 01 DEMOLISH EXISTING HIGH SERVICE PUMPS COMPLETE AND INSPECT PUMP CANS
  - 02 DEMOLISH EXISTING BACKWASH PUMP AND CONCRETE PUMP BASE COMPLETE
  - 03 DEMOLISH EXISTING FLOW METER
  - 04 DEMOLISH EXISTING PROCESS PIPING AND VALVES
  - 05 DEMOLISH EXISTING ELECTRICAL EQUIPMENT
  - 06 DEMOLISH EXISTING MECHANICAL EQUIPMENT
  - 07 REMOVE EXISTING ELEVATED STORAGE TANK PRESSURE TRANSMITTER. EXISTING GROUND STORAGE TANK PRESSURE TRANSMITTER AND PANEL TO REMAIN
  - 08 REMOVE EXISTING AIR RELEASE VALVE AND PRESSURE GAUGE
- SECTION**  
SCALE: 1/4" = 1'-0"
- LEGEND**
- EXISTING FEATURES TO REMAIN
  - DEMOLISH EXISTING FEATURES

**EXISTING HIGH SERVICE PUMP BUILDING  
FLOOR PLAN**  
SCALE: 1/2" = 1'-0"

For Viewing Purposes Only - Visit [www.wesslerengineering.com](http://www.wesslerengineering.com) to Purchase

Drawing: X:\Hogdale\_OH\703222\_Hogdale\_WTP\Contract B - Booster Station and WTP\DWG Sheets\703222-EX-HSP.dwg | Layout: 3D1 | Plotter: 01/20/26 @ 02:30:18 | LastSavedBy: CursiG

SCALE VERIFICATION	DRAWN BY	CLG	NO.	DATE	INITIALS	REVISION DESCRIPTIONS
BAR IS ONE INCH LONG ON ORIGINAL DRAWING	CHECKED BY	MAP				
	APPROVED BY	AMS				
	ISSUE DATE	FEBRUARY 2026				
	PROJECT NUMBER	703222-04-001				

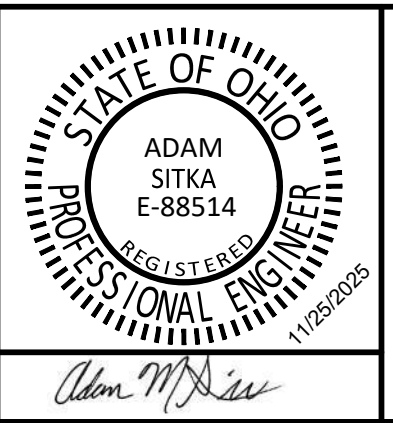

**WATER SYSTEM IMPROVEMENTS**

CONTRACT B NEW BOOSTER STATION AND WATER TREATMENT PLANT IMPROVEMENTS  
VILLAGE OF HOGDALE, OHIO

**EXISTING HIGH SERVICE PUMP BUILDING  
DEMOLITION PLAN**

SHEET NO.  
**3D1**

PAGE NO.  
**15**

DDAGW-4113  
02/20/2026

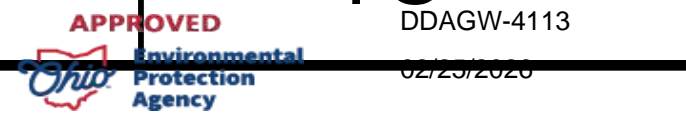

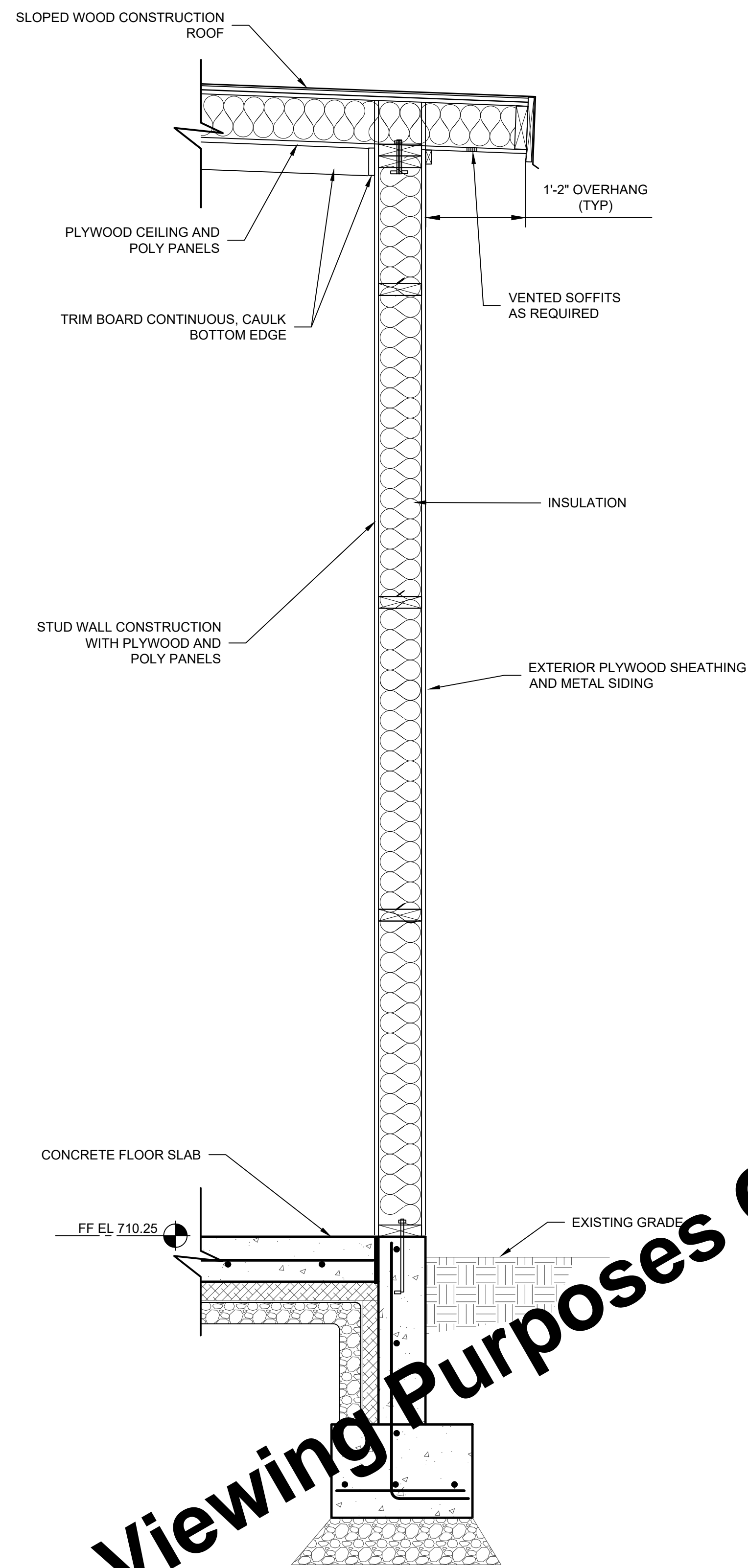

**TYPICAL WALL SECTION**  
SCALE: 1" = 1'-0"

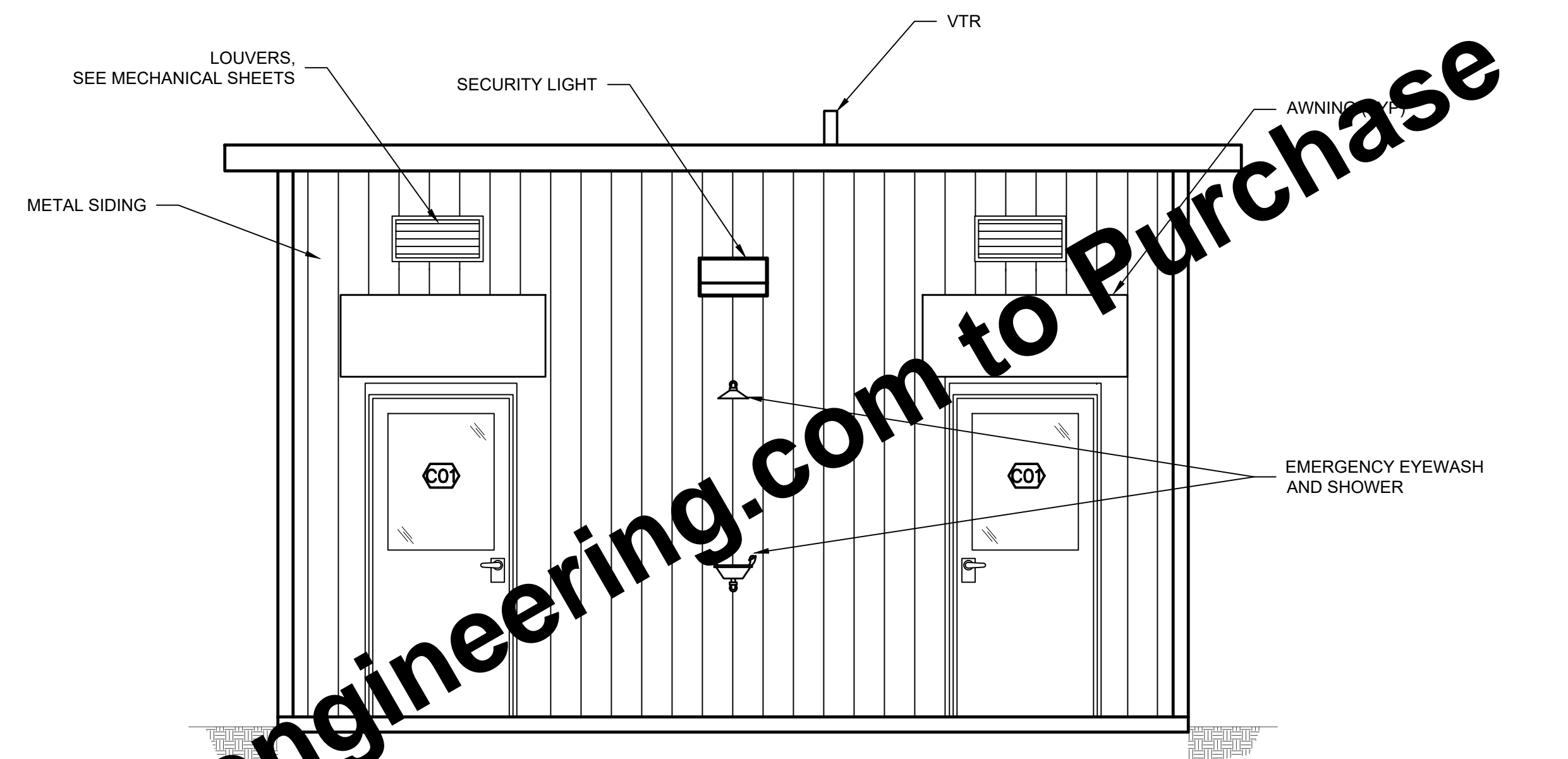

**SOUTH ELEVATION**  
SCALE: 3/8" = 1'-0"

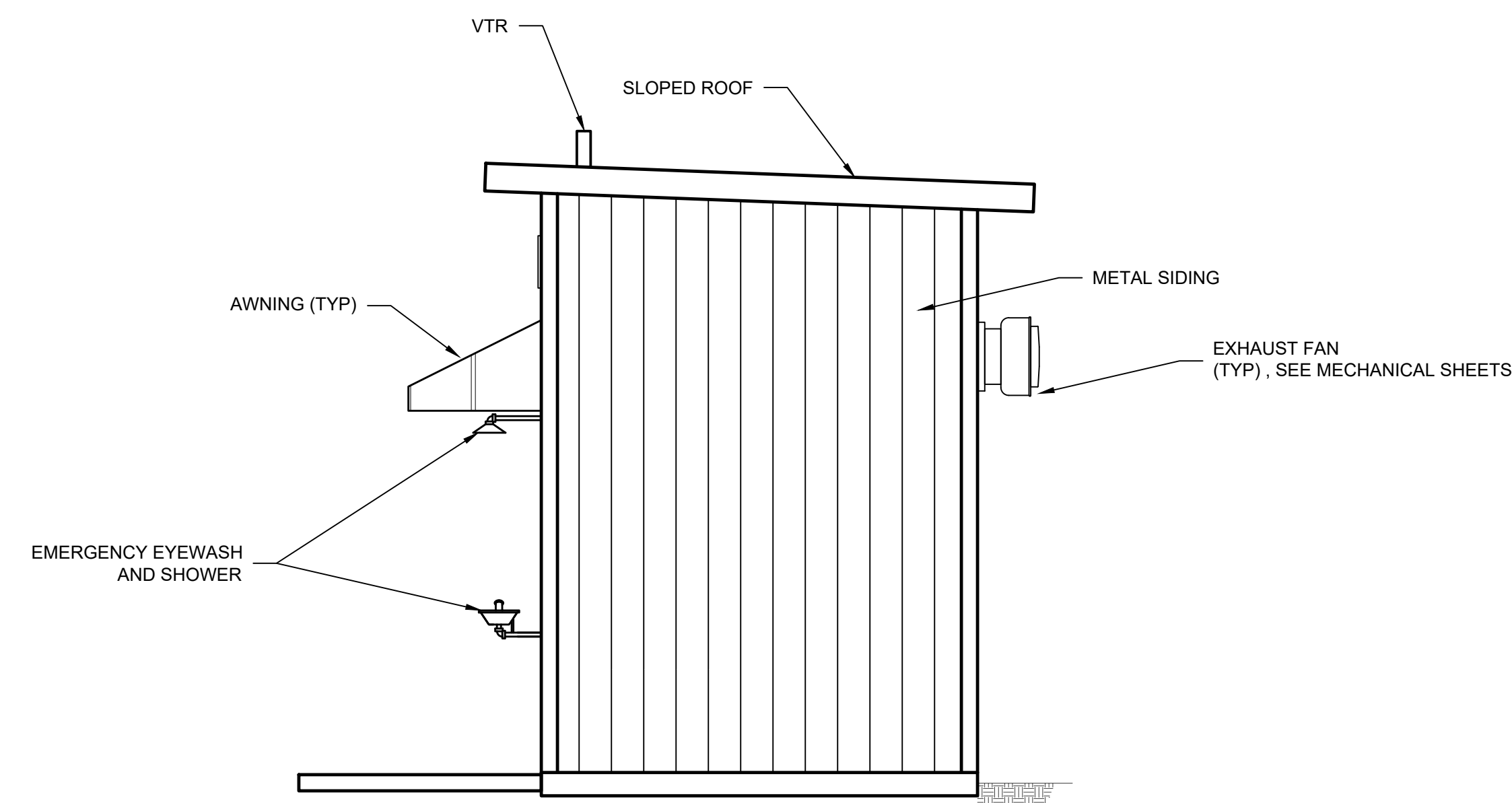

**EAST ELEVATION**  
SCALE: 3/8" = 1'-0"

For Viewing Purposes Only - Visit [www.wesslerengineering.com](http://www.wesslerengineering.com) to Purchase

Drawing: X:\Hogdale\_OH\703222\_Hogdale\_WTP\Contract B - Booster Station and WTP\DWG Sheets\703222-EX-465.dwg | Layout: 3A1 | Plotter: 01/2/2026 @ 02:30:35 | LastSavedBy: ChrisG

SCALE VERIFICATION	DRAWN BY	CLG	NO.	DATE	INITIALS	REVISION DESCRIPTIONS
BAR IS ONE INCH LONG ON ORIGINAL DRAWING 	CHECKED BY	MAP				
	APPROVED BY	AMS				
	ISSUE DATE	FEBRUARY 2026				
	PROJECT NUMBER	703222-04-001				

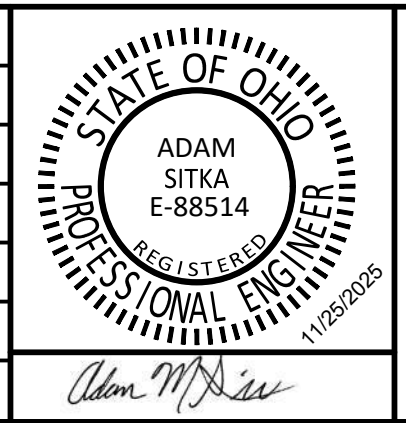

**WATER SYSTEM IMPROVEMENTS**

CONTRACT B NEW BOOSTER STATION AND WATER TREATMENT PLANT IMPROVEMENTS  
VILLAGE OF HOGDALE, OHIO

---

**NEW CHEMICAL BUILDING SECTIONS AND ELEVATIONS**

SHEET NO.  
**3A1**

PAGE NO.  
**16**

DDAGW-4113  
02/20/2026



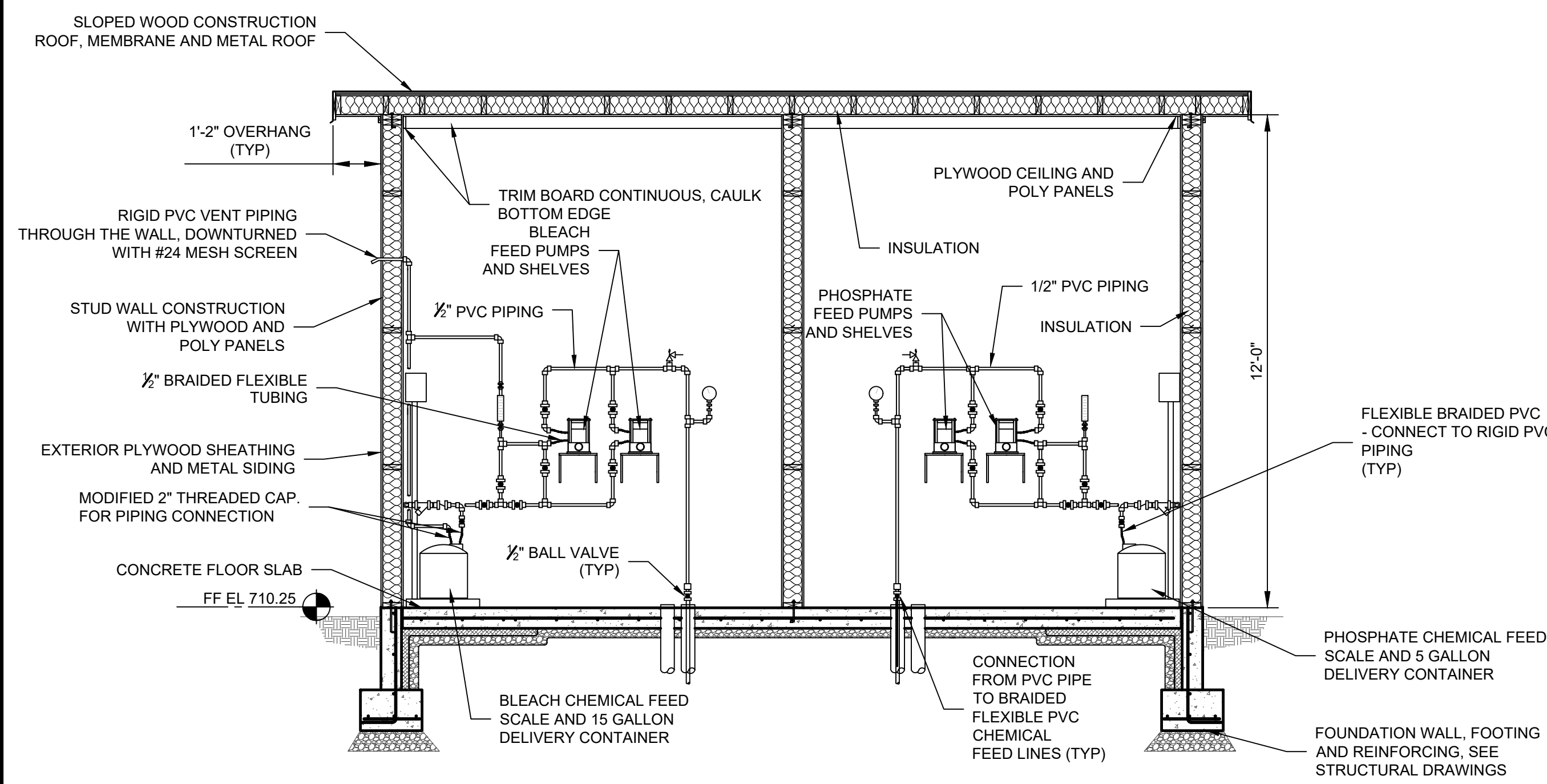

SECTION A  
SCALE: 3/8" = 1'-0"

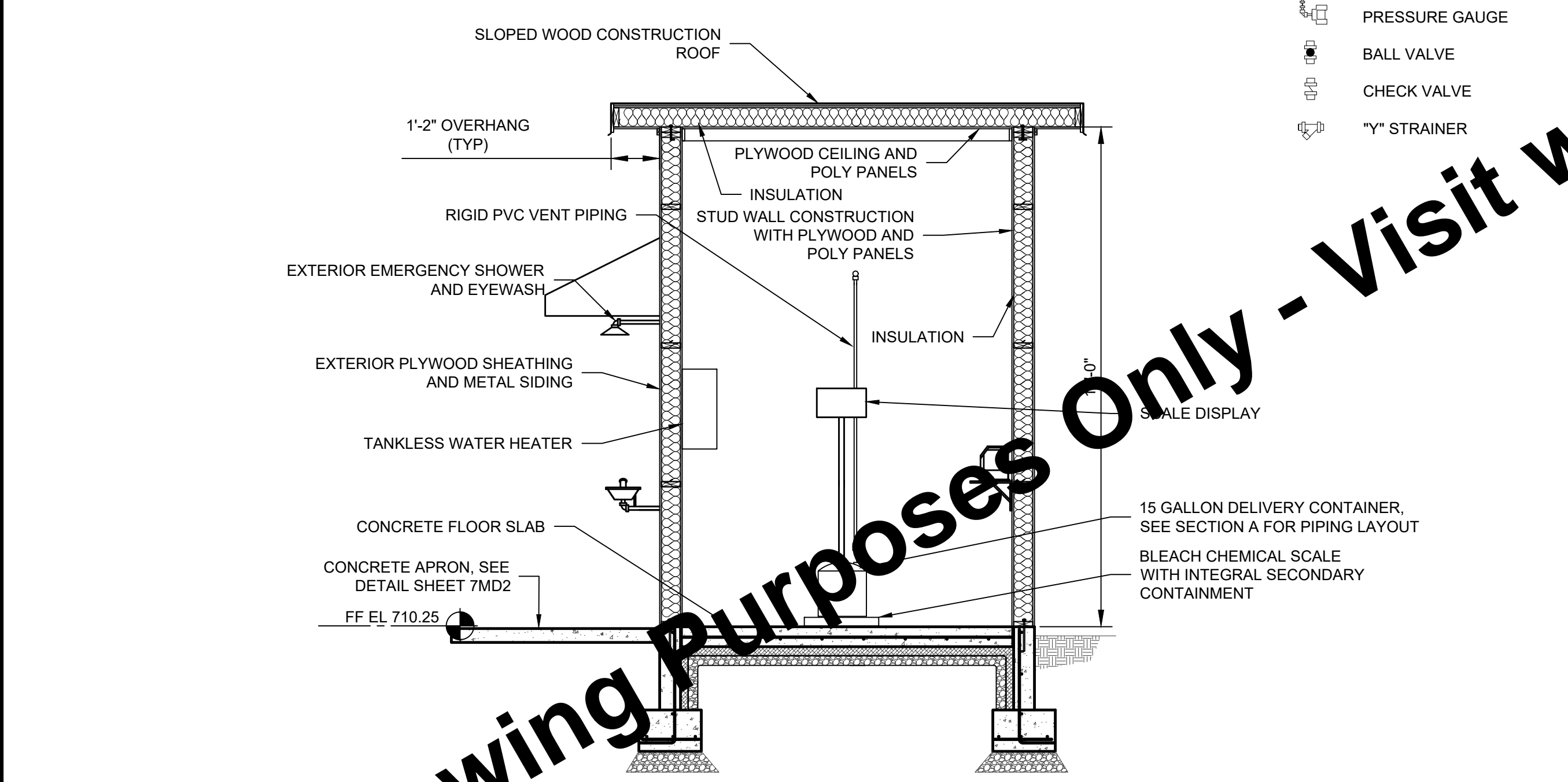

SECTION B  
SCALE: 3/8" = 1'-0"

- LEGEND:**
- CALIBRATION COLUMN
  - PRESSURE RELIEF VALVE
  - PRESSURE GAUGE
  - BALL VALVE
  - CHECK VALVE
  - "Y" STRAINER

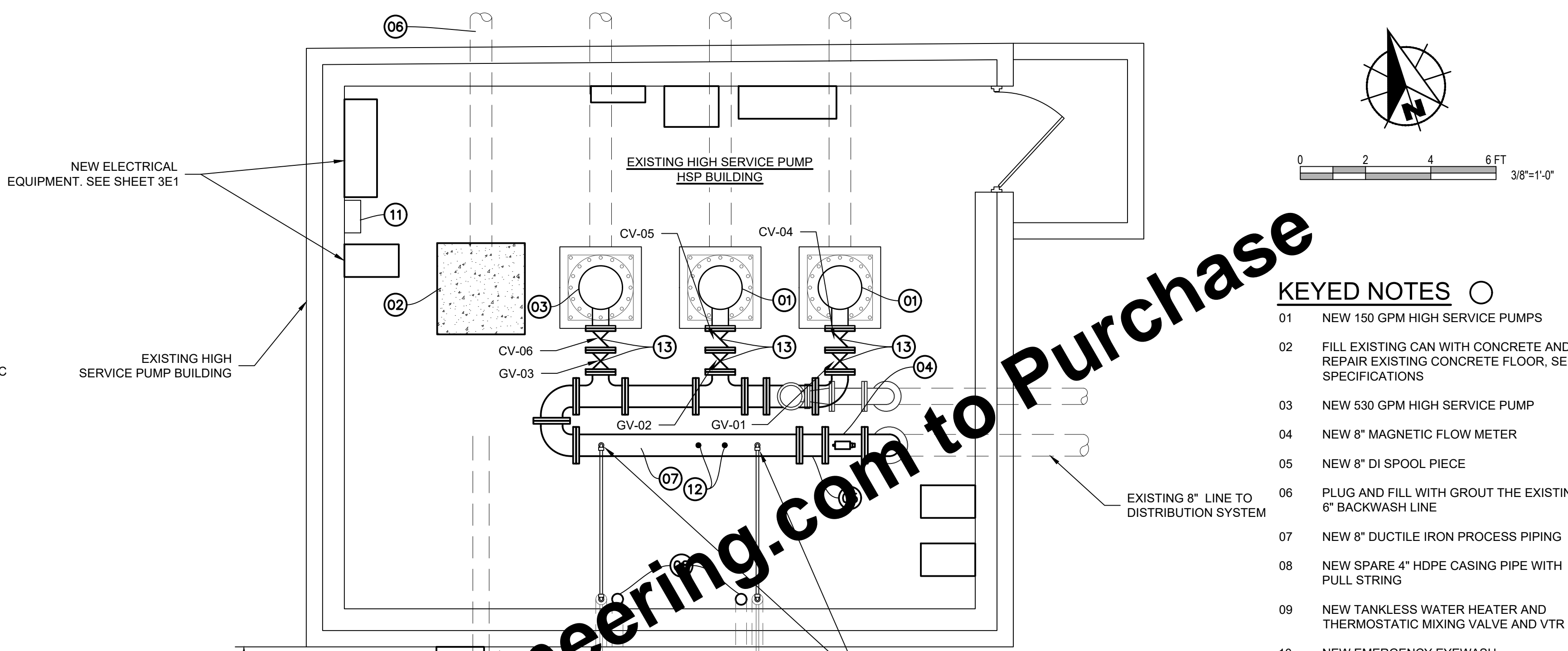

- KEYED NOTES**
- 01 NEW 150 GPM HIGH SERVICE PUMPS
  - 02 FILL EXISTING CAN WITH CONCRETE AND REPAIR EXISTING CONCRETE FLOOR, SEE SPECIFICATIONS
  - 03 NEW 530 GPM HIGH SERVICE PUMP
  - 04 NEW 8" MAGNETIC FLOW METER
  - 05 NEW 8" DI SPOOL PIECE
  - 06 PLUG AND FILL WITH GROUT THE EXISTING 6" BACKWASH LINE
  - 07 NEW 8" DUCTILE IRON PROCESS PIPING
  - 08 NEW SPARE 4" HDPE CASING PIPE WITH PULL STRING
  - 09 NEW TANKLESS WATER HEATER AND THERMOSTATIC MIXING VALVE AND VTR
  - 10 NEW EMERGENCY EYEWASH
  - 11 REPLACE EXISTING GROUND STORAGE TANK PRESSURE TRANSMITTER
  - 12 NEW AIR RELEASE VALVE AND PRESSURE GAUGE
  - 13 NEW 6" CHECK VALVE AND 6" GATE VALVE AND FLANGE FILLERS AS REQUIRED

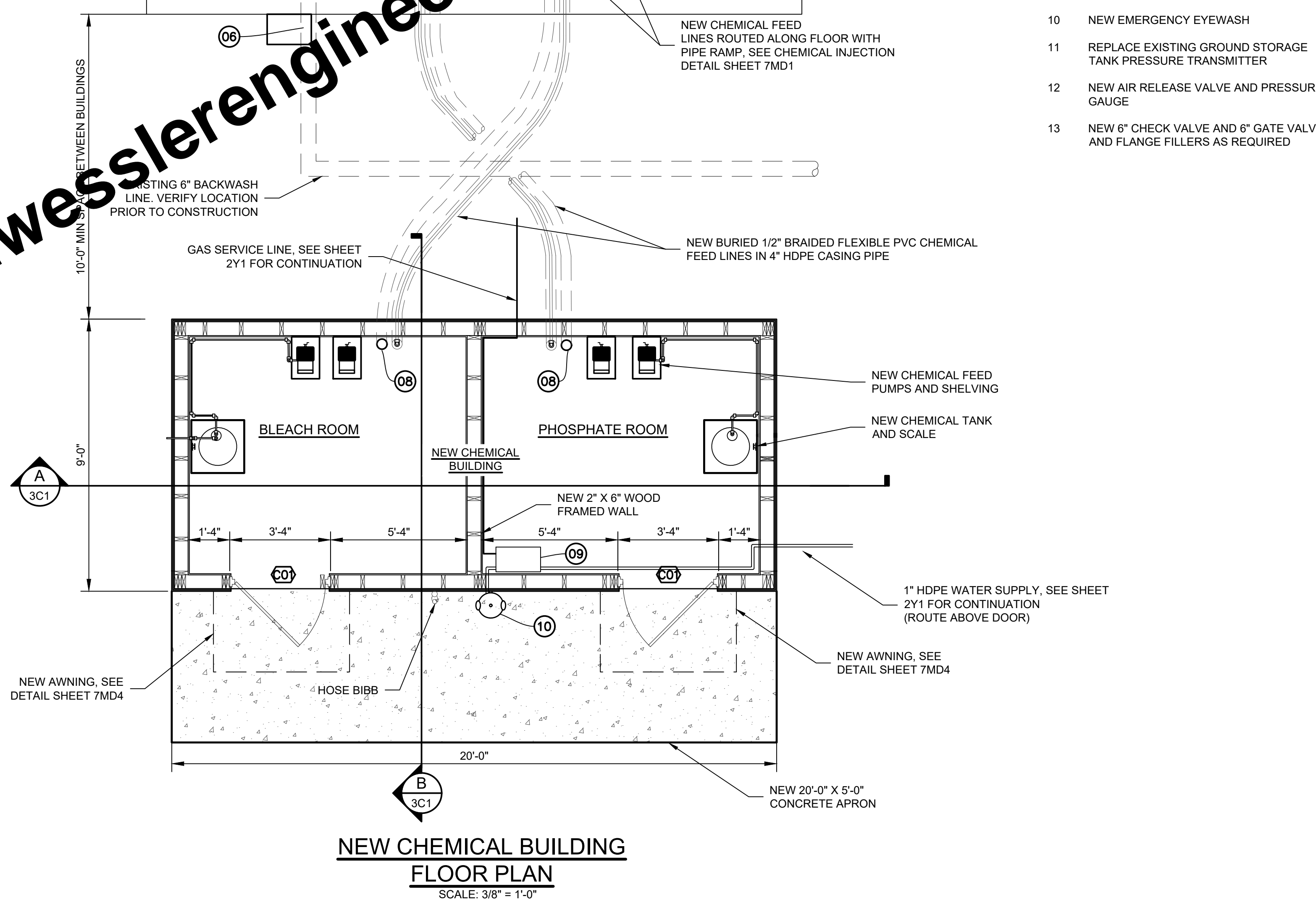

NEW CHEMICAL BUILDING FLOOR PLAN  
SCALE: 3/8" = 1'-0"

For Viewing Purposes Only - Visit [www.wesslerengineering.com](http://www.wesslerengineering.com) to Purchase

SCALE VERIFICATION	DRAWN BY	CLG	NO.	DATE	INITIALS	REVISION DESCRIPTIONS
BAR IS ONE INCH LONG ON ORIGINAL DRAWING	CHECKED BY	MAP				
	APPROVED BY	AMS				
	ISSUE DATE	FEBRUARY 2026				
	PROJECT NUMBER	703222-04-001				

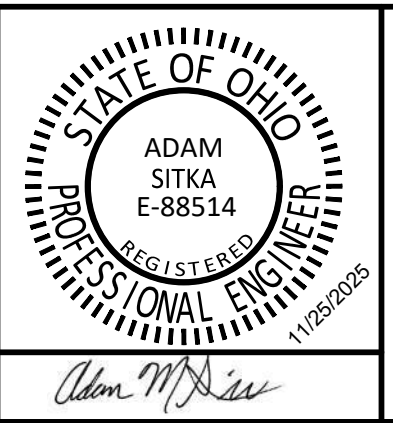

**WATER SYSTEM IMPROVEMENTS**

CONTRACT B NEW BOOSTER STATION AND WATER TREATMENT PLANT IMPROVEMENTS  
VILLAGE OF HOLGATE, OHIO

**NEW CHEMICAL AND EXISTING HIGH SERVICE PUMP BUILDINGS**

**FLOOR PLAN**

SHEET NO.  
**3C1**

PAGE NO.  
**17**

DDAGW-4113

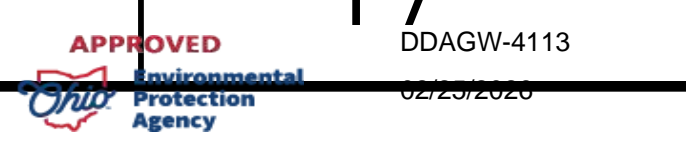

Drawing: X:\Holgeatle\_Ohio\703222\_Holgeatle\_WTP\DWG\Sheets\703222-EX-468P.dwg | Layout: 3C1 | Plotter: 01/20/26 @ 02:29:51 | LastSavedBy: CursiG

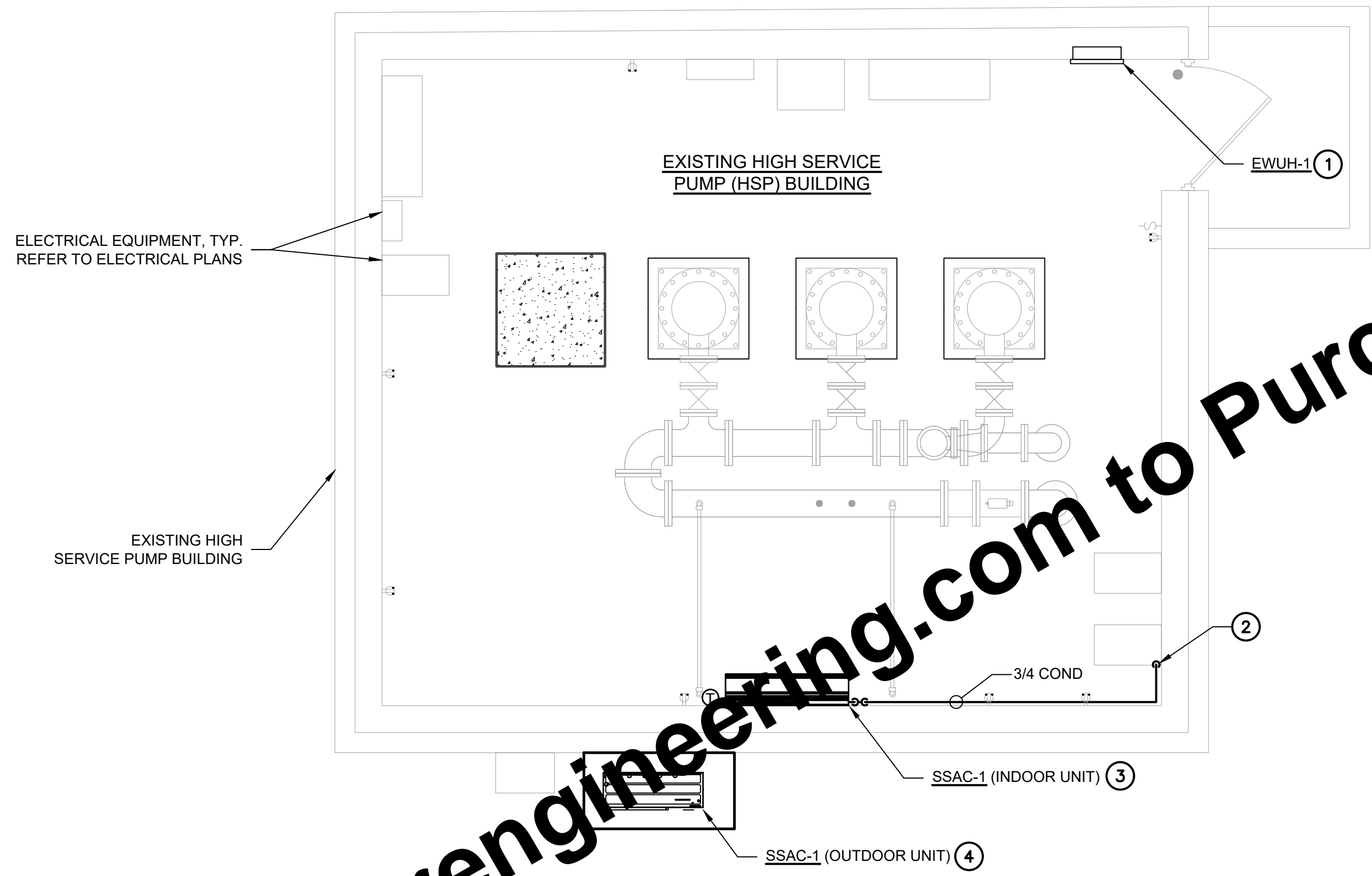
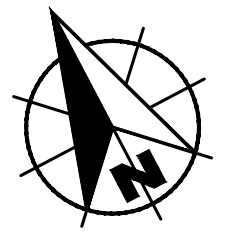

**LEGEND**

EXISTING OR WORK BY OTHERS

NEW FEATURES

- GENERAL NOTES**
- REFER TO SHEET 1M1 MECHANICAL SYMBOLS AND NOTATION FOR ADDITIONAL REQUIREMENTS.
  - INSULATE DUCTWORK BETWEEN EXTERIOR WALL AND MOTORIZED ISOLATION DAMPERS.
  - ALL DUCTWORK, SUPPORTS, HANGERS AND FASTENERS IN THE CHEMICAL BUILDING SHALL BE STAINLESS STEEL. SEE EQUIPMENT SCHEDULES FOR EQUIPMENT MATERIALS.

- KEYED NOTES**
- EXPAND EXISTING OPENING IN WALL AS NEEDED TO RECESS NEW UNIT HEATER. SET INTEGRAL THERMOSTAT TO MAINTAIN 50°.
  - ROUTE CONDENSATE LINE DOWN ON WALL FROM UNIT TO BELOW ELECTRICAL OUTLETS. SLOPE TO DRAIN AS SHOWN. TERMINATE AT EXISTING FLOOR OPENING WITH AIR GAP FITTING.
  - MOUNT INDOOR UNIT AT 8'-0" A.F.F.
  - MOUNT OUTDOOR UNIT ON 8" HOUSEKEEPING PAD, TOP AT 4" ABOVE GRADE, MINIMUM 6" WIDER THAN UNIT IN EACH DIRECTION.
  - MOUNT BOTTOM OF FAN AT 8'-0" A.F.F.
  - MOUNT BOTTOM AT 8'-0" A.F.F. PROVIDE WALL REINFORCEMENT AS NEEDED FOR FACTORY WALL MOUNT KIT.
  - STAINLESS STEEL SHEET METAL SLEEVE THROUGH WALL, CENTERED ON DOOR, BOTTOM AT 10'-0" A.F.F. COVER OPENING WITH 1/2" x 1/2" STAINLESS STEEL WIRE MESH.
  - DROP DUCT TO 6" A.F.F., COVER OPENING WITH 1/2" x 1/2" STAINLESS STEEL WIRE MESH.
  - EXHAUST FAN SWITCH BY E.C., PROVIDE PLACARD ADJACENT TO SWITCH WITH 1/2" LETTERING THAT READS "VENTILATE ROOM PRIOR TO ENTRY"
  - NEMA 4X CORROSION RESISTANT LINE VOLTAGE THERMOSTAT.

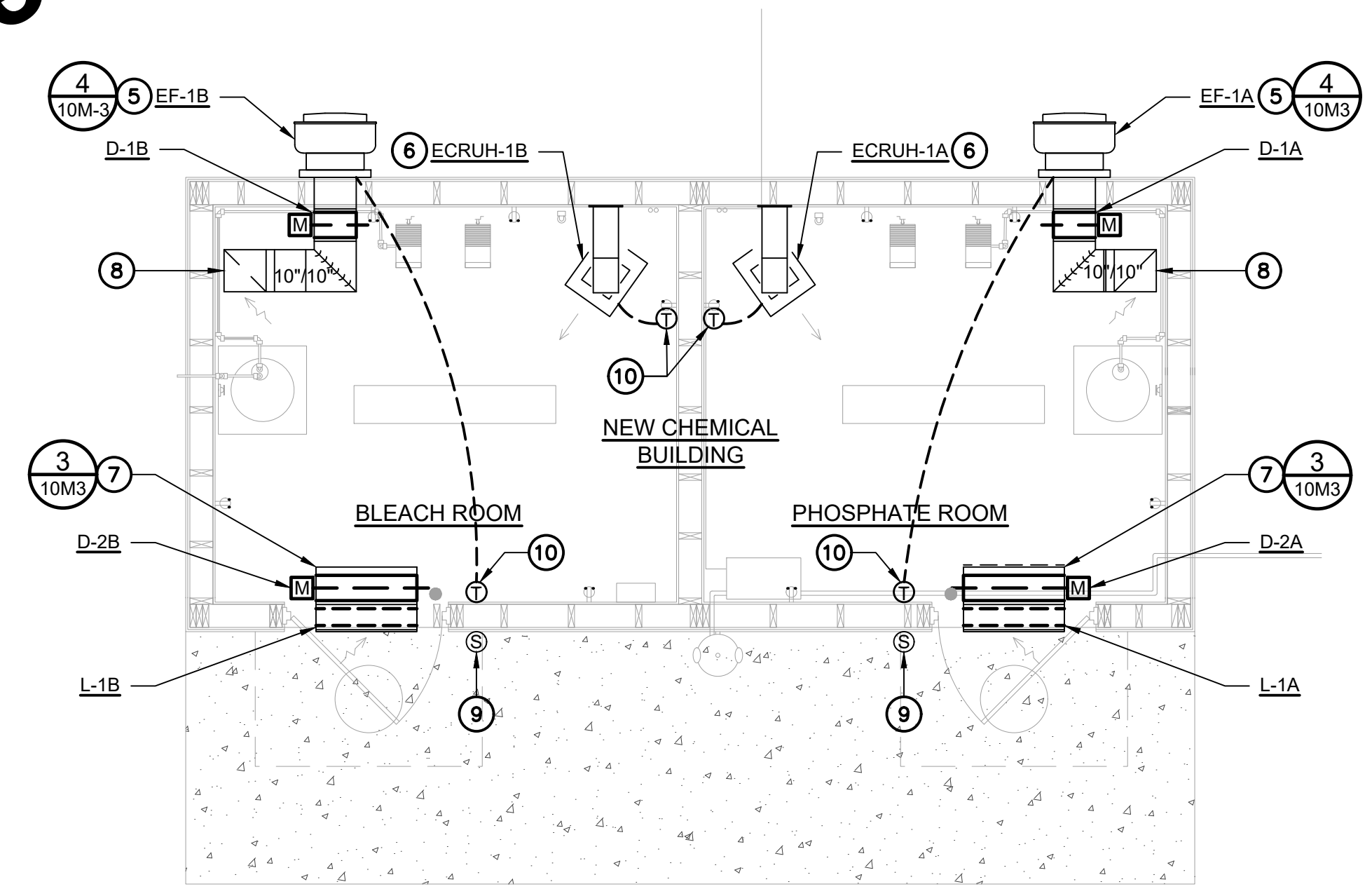

For Viewing Purposes Only - Visit [www.wesslerengineering.com](http://www.wesslerengineering.com) to Purchase

SCALE VERIFICATION	DRAWN BY	CLG	NO.	DATE	INITIALS	REVISION DESCRIPTIONS
BAR IS ONE INCH LONG ON ORIGINAL DRAWING	CHECKED BY	SPR				
	APPROVED BY	WCM				
	ISSUE DATE	FEBRUARY 2026				
	PROJECT NUMBER	703222-04-001				

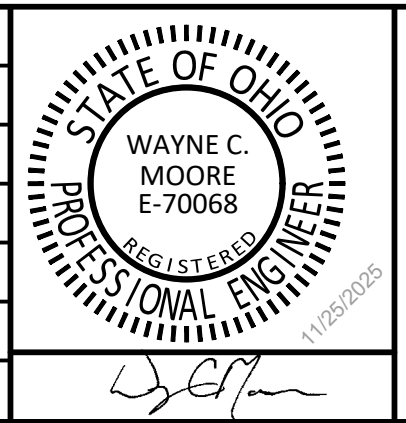

**WATER SYSTEM IMPROVEMENTS**

CONTRACT B NEW BOOSTER STATION AND WATER TREATMENT PLANT IMPROVEMENTS  
VILLAGE OF HOLGATE, OHIO

**NEW CHEMICAL AND EXISTING HIGH SERVICE PUMP BUILDINGS**

**HVAC PLAN**

SHEET NO.  
**3M1**

PAGE NO.  
**18**

DDAGW-4113

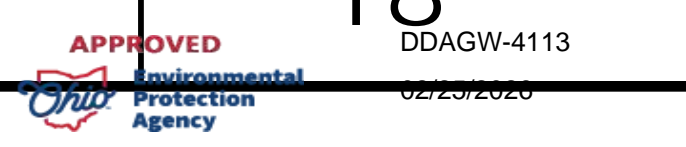

Drawing: X:\Hologate\_C01703222\_Hologate\_Village\WTP\Contract B - Booster Station and WTP\DWG Sheets\703222-04-001-MECH.dwg | Layout: 3M1 | Printer: 01/20/26 @ 02:35:56 | User: Smeadby, CursiG

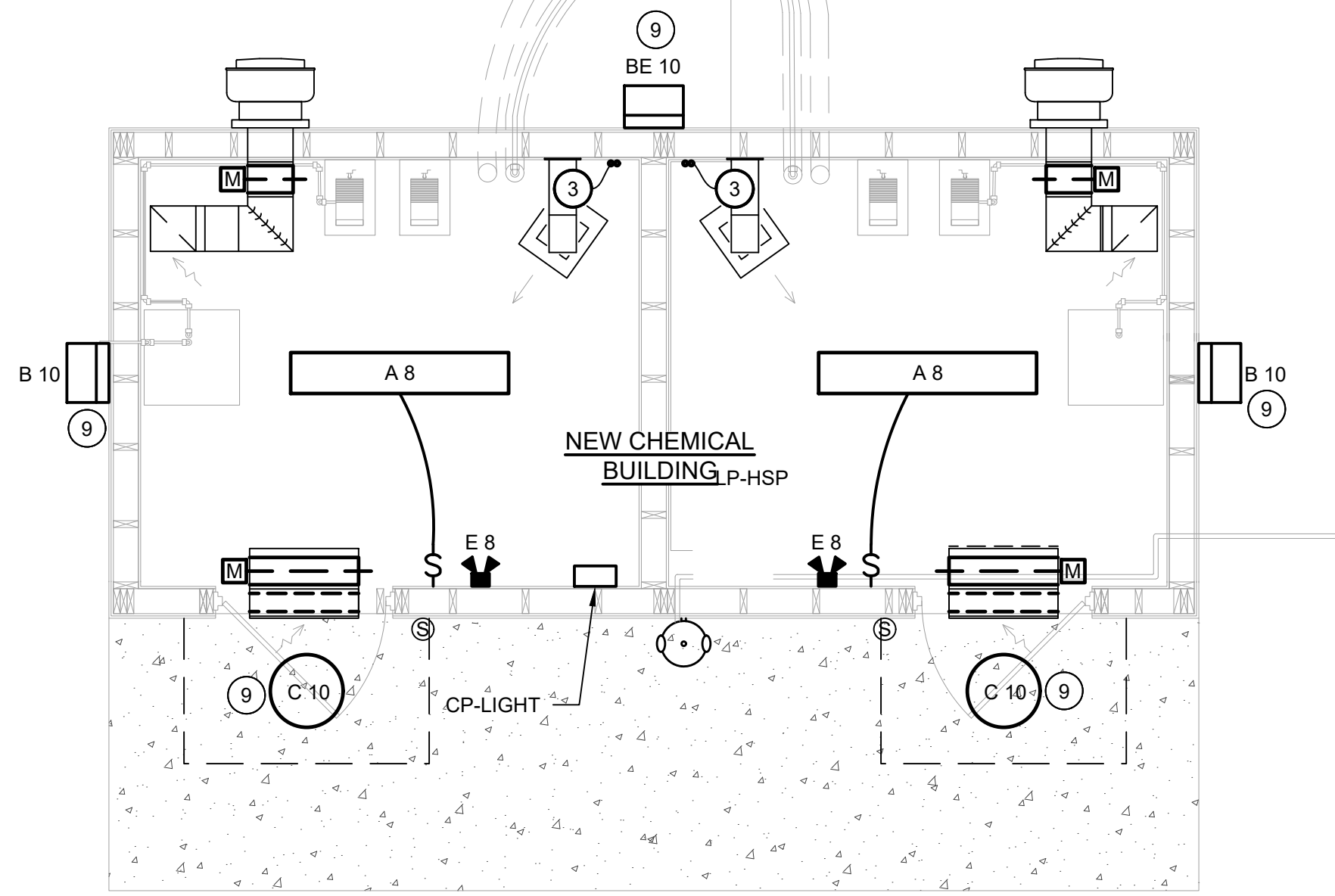
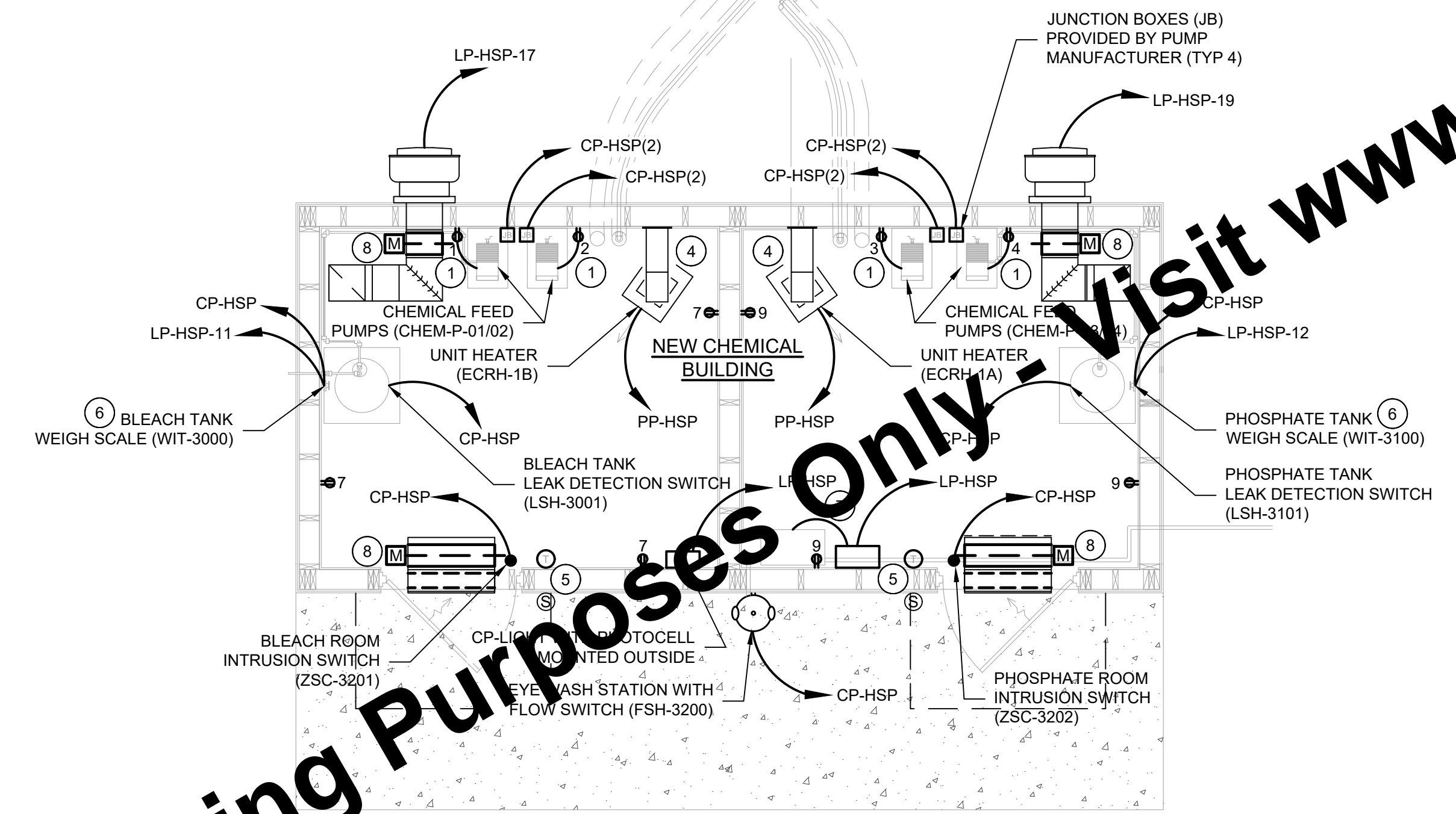
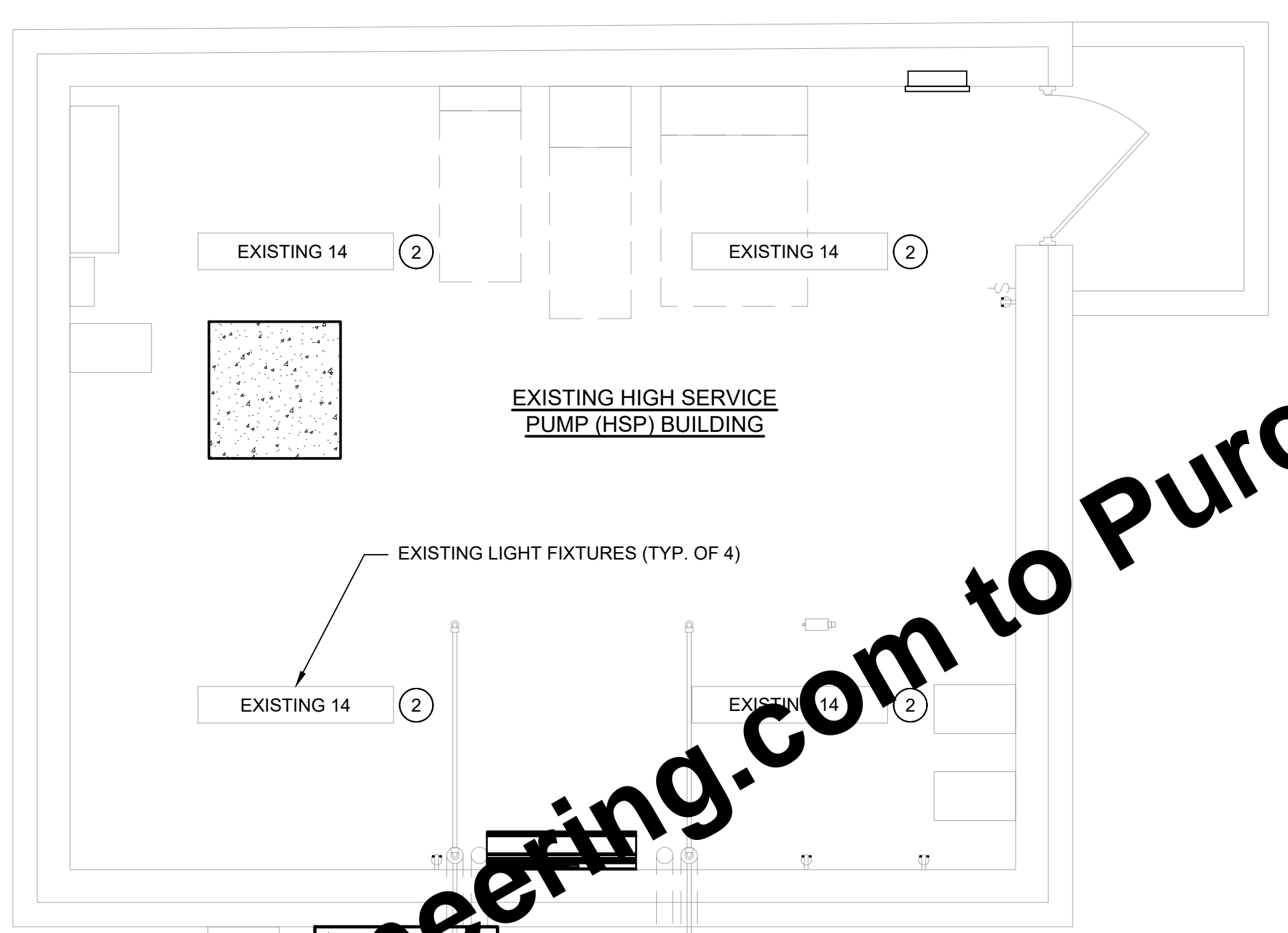
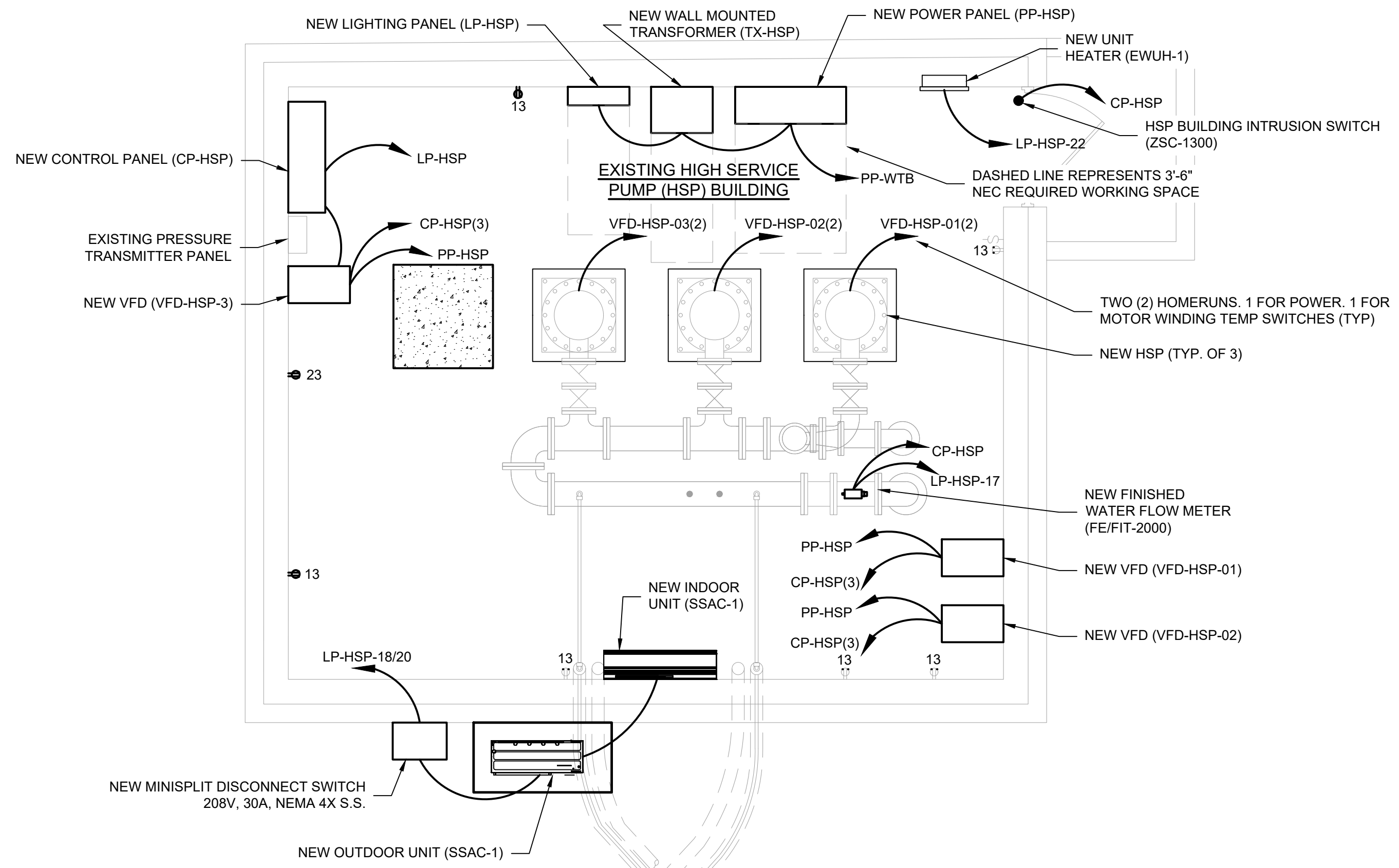

**ELECTRICAL PLAN**  
SCALE: 3/8" = 1'-0"

**LIGHTING PLAN**  
SCALE: 3/8" = 1'-0"

- KEYED NOTES**
1. DEDICATED RECEPTACLE FOR CHEMICAL FEED PUMP. EACH FEED PUMP TO HAVE ITS OWN DEDICATED CIRCUIT AS SHOWN.
  2. REWIRE EXISTING LIGHT FIXTURES TO NEW LP-HSP PANELBOARD AS SHOWN.
  3. PROVIDE FOUR (4) SPARE CONDUITS BETWEEN THE HSP BUILDING AND THE NEW CHEMICAL BUILDING (2 PER CHEMICAL ROOM):  
2X 1" C FROM LP-HSP TO EACH CHEMICAL ROOM  
2X 1" C FROM CP-HSP TO EACH CHEMICAL ROOM
  4. STUB UP AND CAP ALL CONDUITS. UNIT HEATER PROVIDED WITH INTEGRAL DISCONNECT SWITCH BY MANUFACTURER. WALL SWITCH AND TEMPERATURE SWITCH TO CONTROL CORRESPONDING CHEMICAL ROOM EXHAUST FAN. SWITCH TO BE PROVIDED WITH WEATHER PROOF COVER AND CLEARLY LABELED FOR EXHAUST FAN. PROVIDE ALL NECESSARY WIRING FOR DAMPERS IN 3/4" C MINIMUM. WIRING SCHEMATIC LOCATED ON SHEET 8E7.
  5. PROVIDE SMALL, ROTARY, WALL MOUNTED, NEMA4X SWITCH TO ACT AS LOCAL DISCONNECT FOR THIS EQUIPMENT.
  6. TANKLESS GAS WATER HEATER AND LOCAL NEMA4X DISCONNECT SWITCH.
  7. INTERLOCK DAMPERS WITH EXHAUST FAN AS DESCRIBED ON SHEET 10M3. PROVIDE CONDUIT AND WIRE AS REQUIRED.
  8. CP-LIGHT TO CONTROL ALL EXTERIOR MOUNTED LIGHTING FIXTURES. SEE DETAIL ON SHEET 8E7.

- GENERAL NOTES:**
1. ALL CONDUIT IN CHEMICAL AREAS TO BE SCHEDULE 80 PVC.
  2. ALL RECEPTACLES IN CHEMICAL AREAS TO BE 20A, CORROSION RESISTANT AND INSTALLED WITH "IN USE" COVERS.
  3. ALL OUTDOOR RECEPTACLES TO BE WEATHER RESISTANT, 20A, GFCI PROTECTED, AND INSTALLED WITH "IN USE" COVERS.
  4. REFEED ALL EXISTING 120/208V EQUIPMENT IN THE HSP BUILDING FROM NEW PANELBOARD LP-HSP, INCLUDING LIGHTING AND RECEPTACLES AS SHOWN. REPLACE ALL WIRE, RECEPTACLES, AND SWITCHES; REUSE EXISTING CONDUIT WHERE FEASIBLE. EXISTING WIRING DEVICES ARE SHOWN HALF-TONE FOR CLARITY BUT SHALL BE REPLACED. NEW WIRING DEVICES (3 RECEPTACLES SHOWN IN BOLD) REQUIRE NEW CONDUIT.

For Viewing Purposes Only - Visit [www.wesslerengineering.com](http://www.wesslerengineering.com) to Purchase

SCALE VERIFICATION	DRAWN BY	JLK	NO.	DATE	INITIALS	REVISION DESCRIPTIONS
BAR IS ONE INCH LONG ON ORIGINAL DRAWING	CHECKED BY	JAP				
	APPROVED BY	WCM				
	ISSUE DATE	FEBRUARY 2026				
	PROJECT NUMBER	703222-04-001				

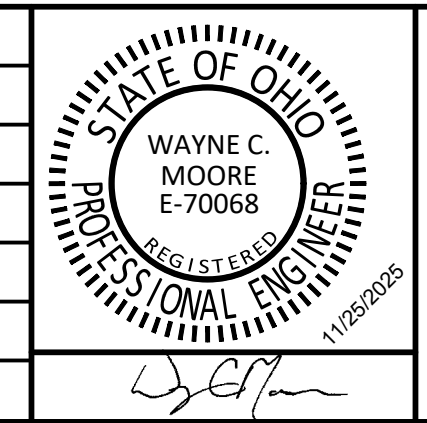

<b>WATER SYSTEM IMPROVEMENTS</b>	SHEET NO.
CONTRACT B NEW BOOSTER STATION AND WATER TREATMENT PLANT IMPROVEMENTS VILLAGE OF HOLGATE, OHIO	3E1
<b>NEW CHEMICAL AND EXISTING HIGH SERVICE BUILDINGS</b>	PAGE NO.
<b>ELECTRICAL PLAN</b>	19
	DDAGW-4113

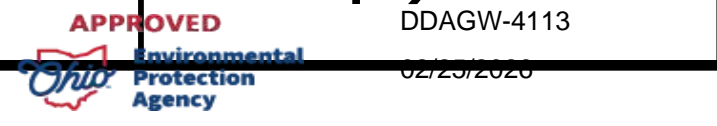

Drawing: X:\Holgeat\_Chi\703222\_Holgeat\_WTP\Contract B - Booster Station and WTP\DWG\Sheets\703222-EX-HSP-EL.dwg | Layout: 3E1 | Plot: 01/20/26 @ 10:09:26 | LastSavedBy: jshk

For Viewing Purposes Only - Visit [www.wesslerengineering.com](http://www.wesslerengineering.com) to Purchase



PERSPECTIVE VIEW - SOUTHWEST

SCALE: NONE

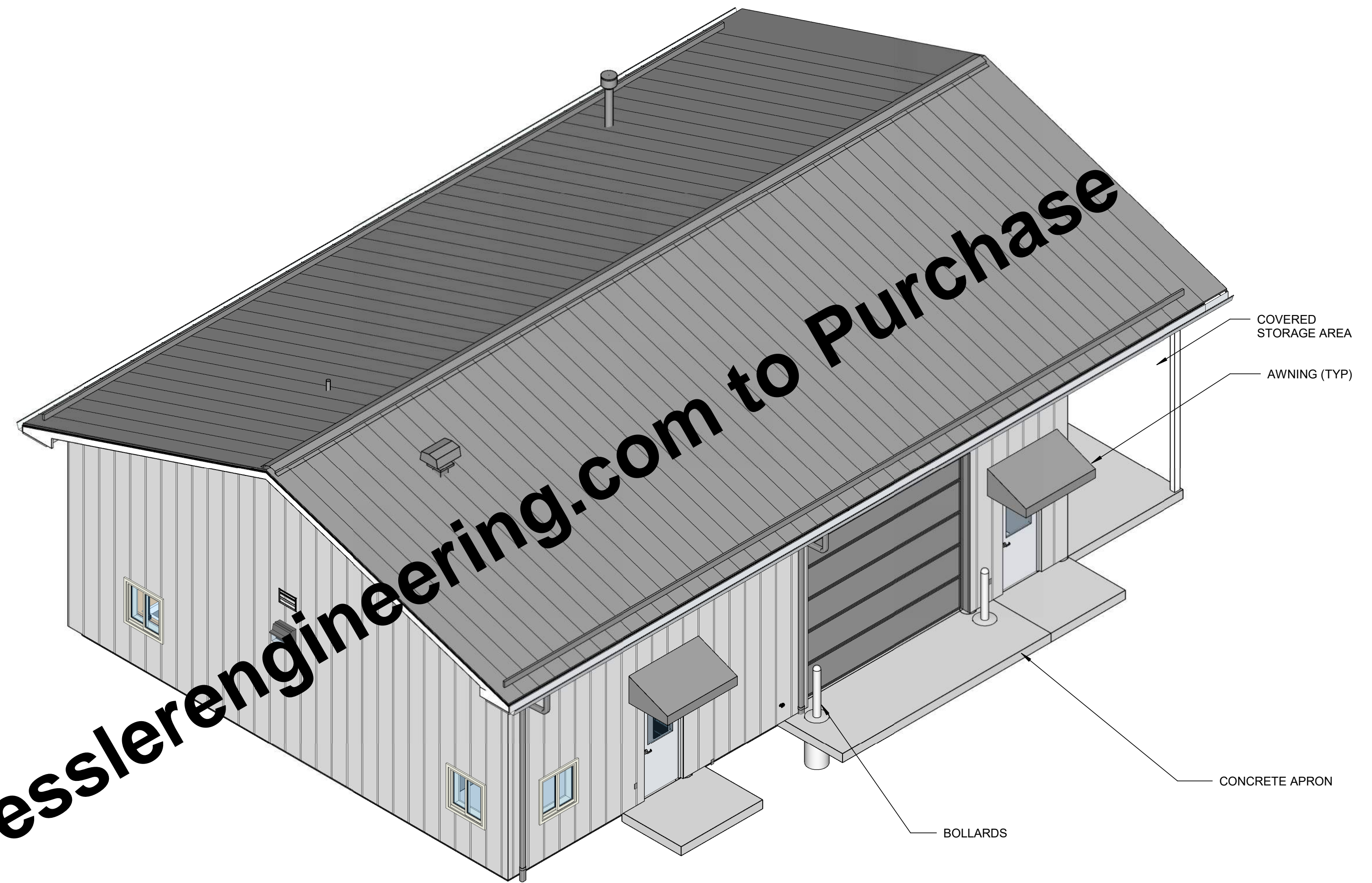

PERSPECTIVE VIEW - NORTHEAST

SCALE: NONE

Plotted: 1/22/2026 8:20:54 AM C:\Autodesk\Revit Local\703222-1MB-NEW-GEN-PCS\_CurtisGramann.rvt

SCALE VERIFICATION  BAR IS ONE INCH LONG ON ORIGINAL DRAWING  	DRAWN BY	CLG	NO.	DATE	INITIALS	REVISION DESCRIPTION
	CHECKED BY	MAP				
	APPROVED BY	AMS				
	ISSUE DATE					
	FEBRUARY 2026					
PROJECT NUMBER						
703222-04-001						

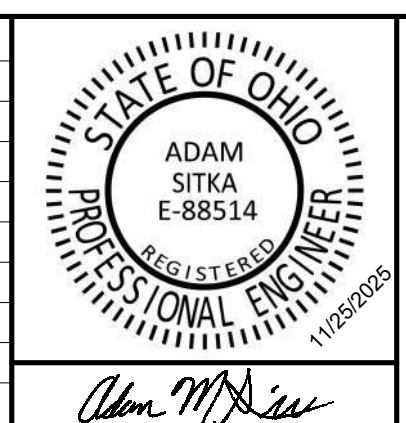

**WATER SYSTEM IMPROVEMENTS**

CONTRACT B NEW BOOSTER STATION AND TREATMENT PLANT IMPROVEMENTS  
VILLAGE OF HOLGATE, OHIO

**NEW WATER TREATMENT BUILDING**

**PERSPECTIVE VIEWS**

SHEET NO.	4G1
PAGE NUMBER	20
DDAGW-4113	02/25/2026



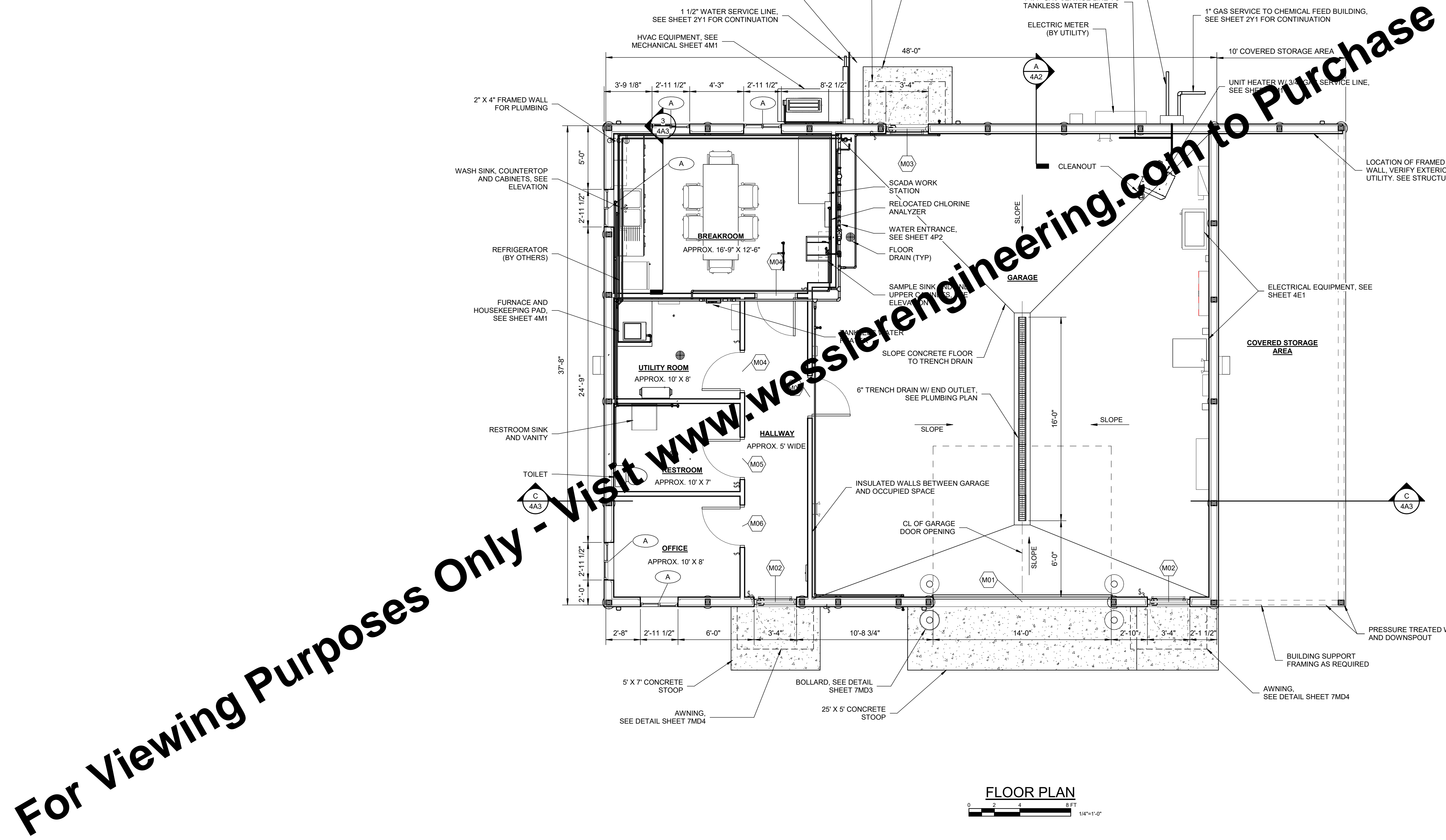
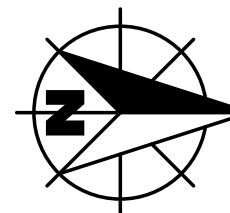

**FLOOR PLAN**  
 0 2 4 8 FT  
 1/4"=1'-0"

**For Viewing Purposes Only - Visit [www.wesslerengineering.com](http://www.wesslerengineering.com) to purchase**

SCALE VERIFICATION	DRAWN BY	CLG	NO.	DATE	INITIALS	REVISION DESCRIPTION
BAR IS ONE INCH LONG ON ORIGINAL DRAWING 	CHECKED BY	MAP				
	APPROVED BY	AMS				
	ISSUE DATE	FEBRUARY 2026				
	PROJECT NUMBER	703222-04-001				

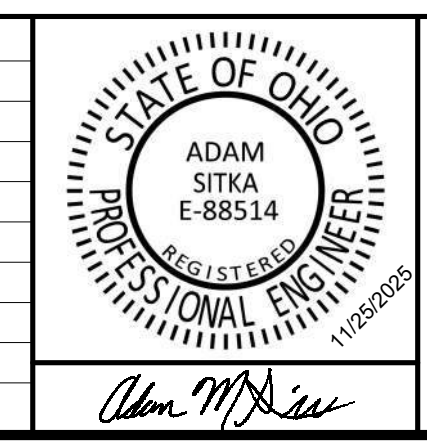

**WATER SYSTEM IMPROVEMENTS**  
 CONTRACT B NEW BOOSTER STATION AND TREATMENT PLANT IMPROVEMENTS  
 VILLAGE OF HOLGATE, OHIO  
**NEW WATER TREATMENT BUILDING**  
**FLOOR PLAN**

SHEET NO.	<b>4A1</b>
PAGE NUMBER	21
DDAGW-4113	02/25/2026



Plotted: 1/22/2026 8:22:29 AM C:\Autodesk\Revit Local\703222-MB-NEW-GEN-PCS\_CurtisGraham.rvt

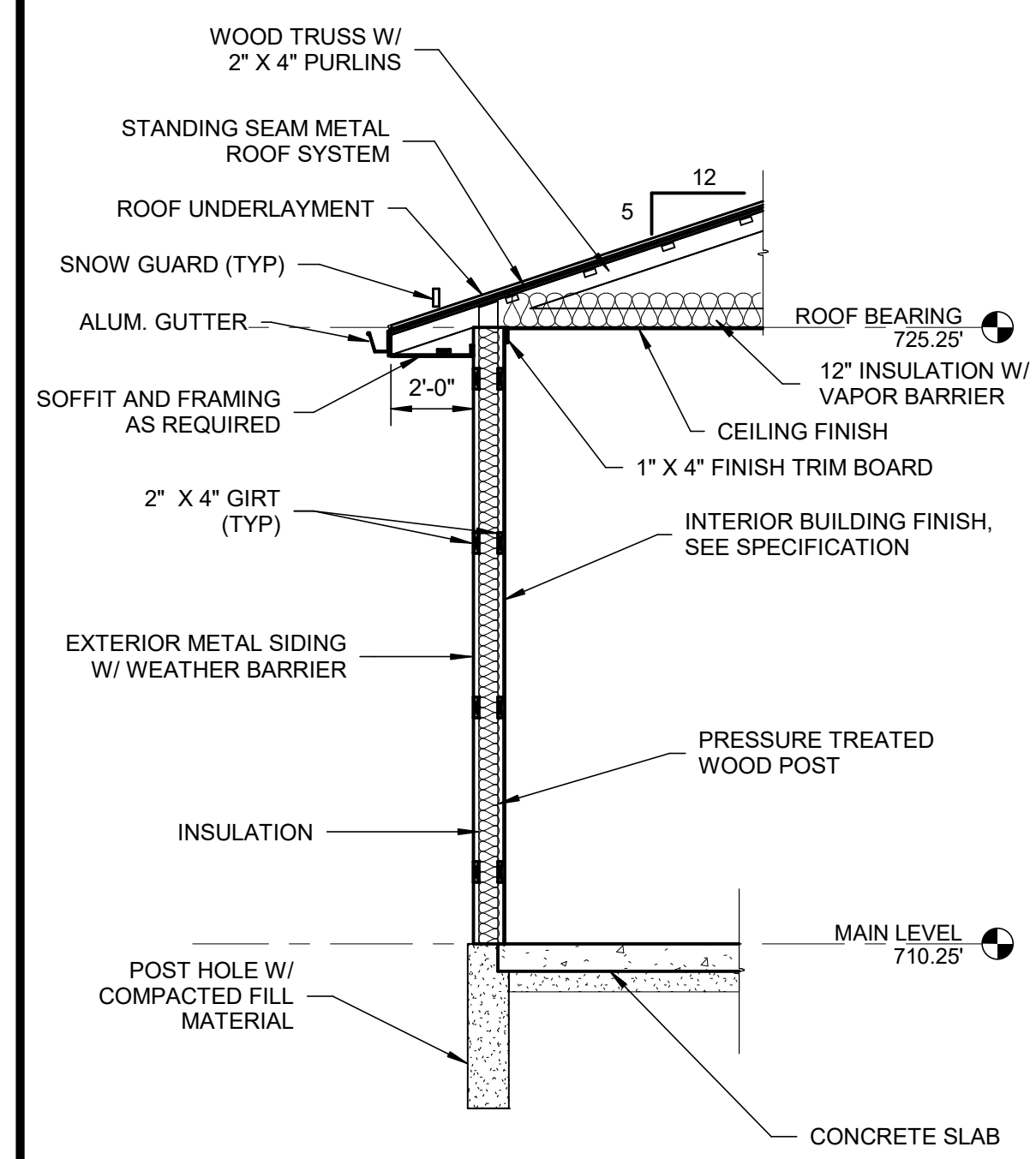

**EXTERIOR WALL SECTION**

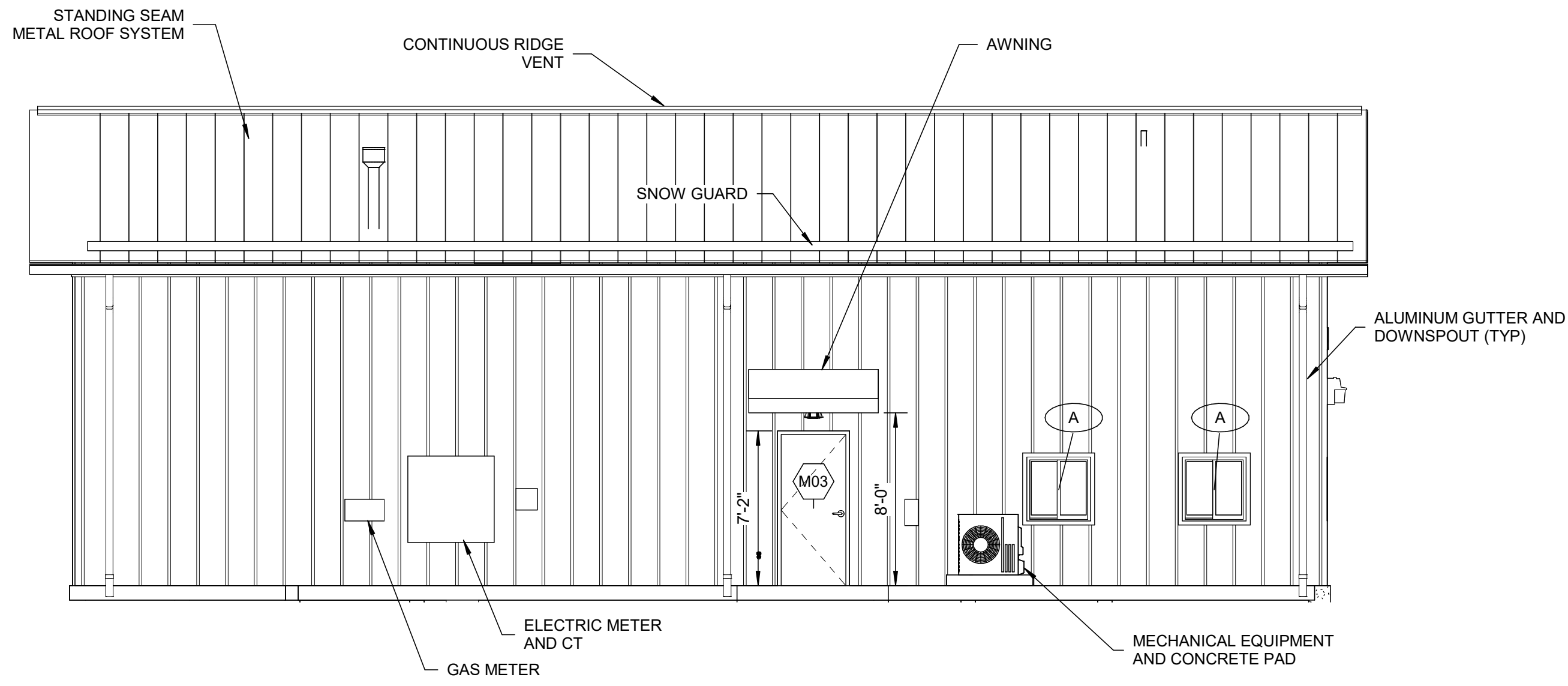
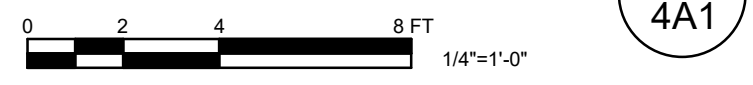

**WEST ELEVATION**  
SCALE: 3/16" = 1'-0"

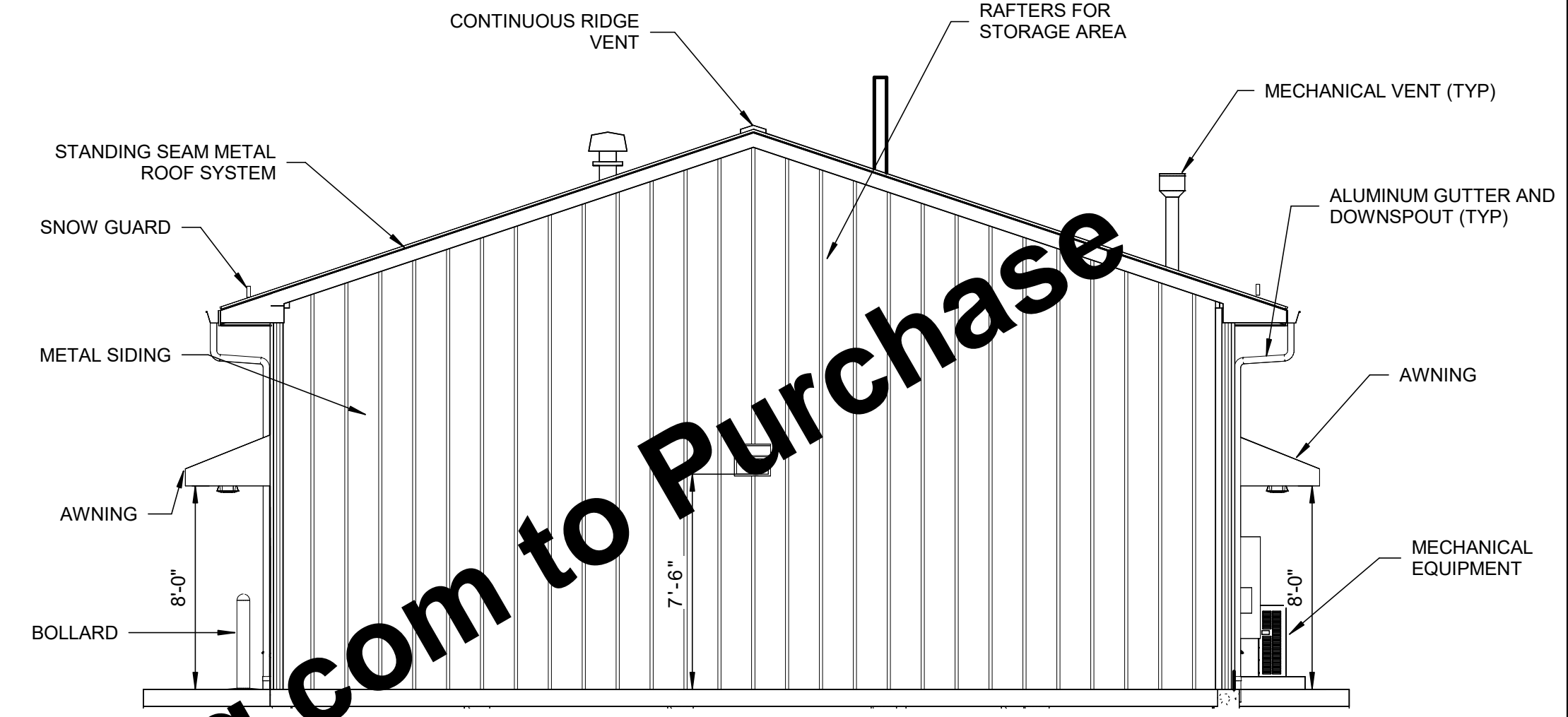

**NORTH ELEVATION**  
SCALE: 3/16" = 1'-0"

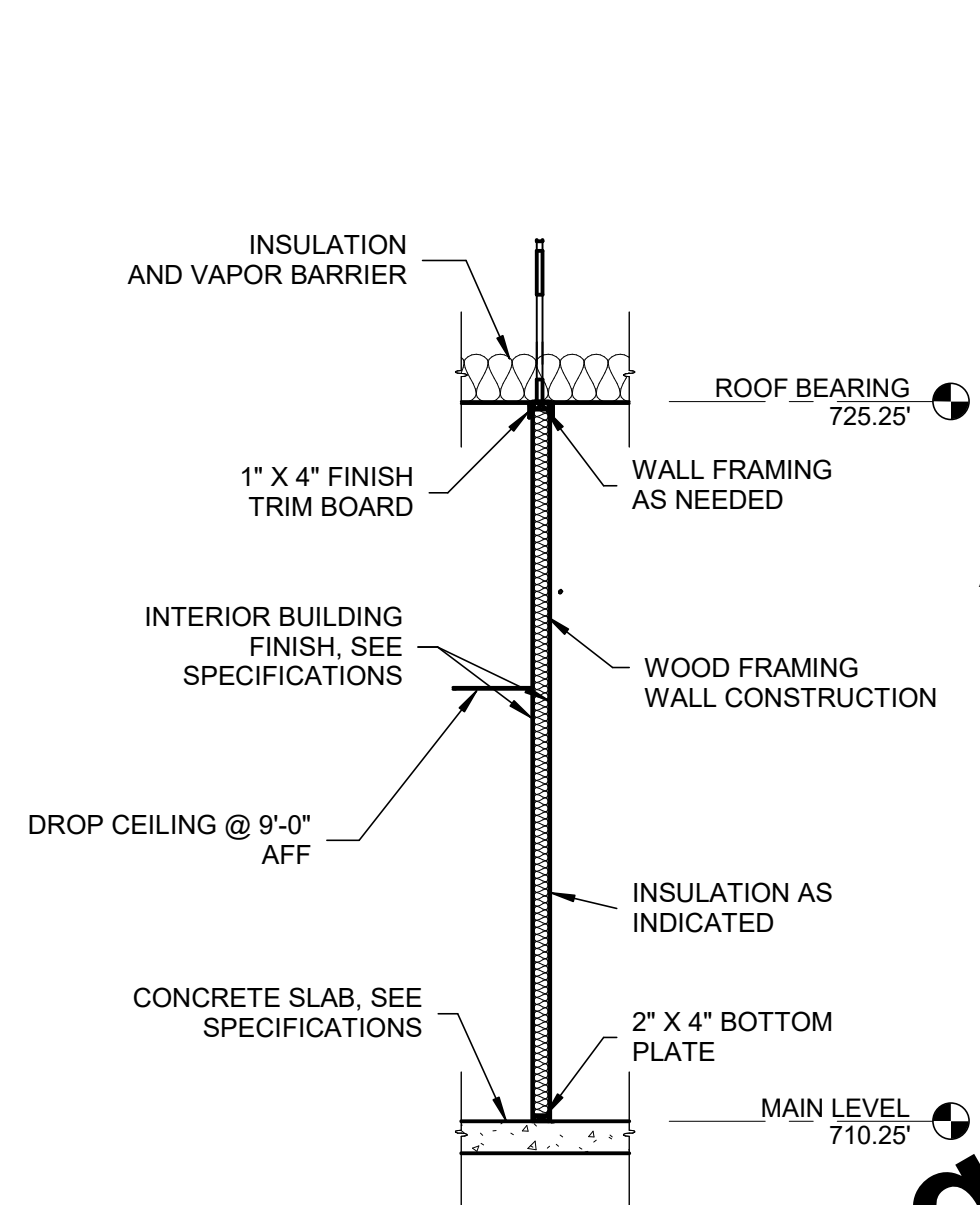

**INTERIOR WALL SECTION**

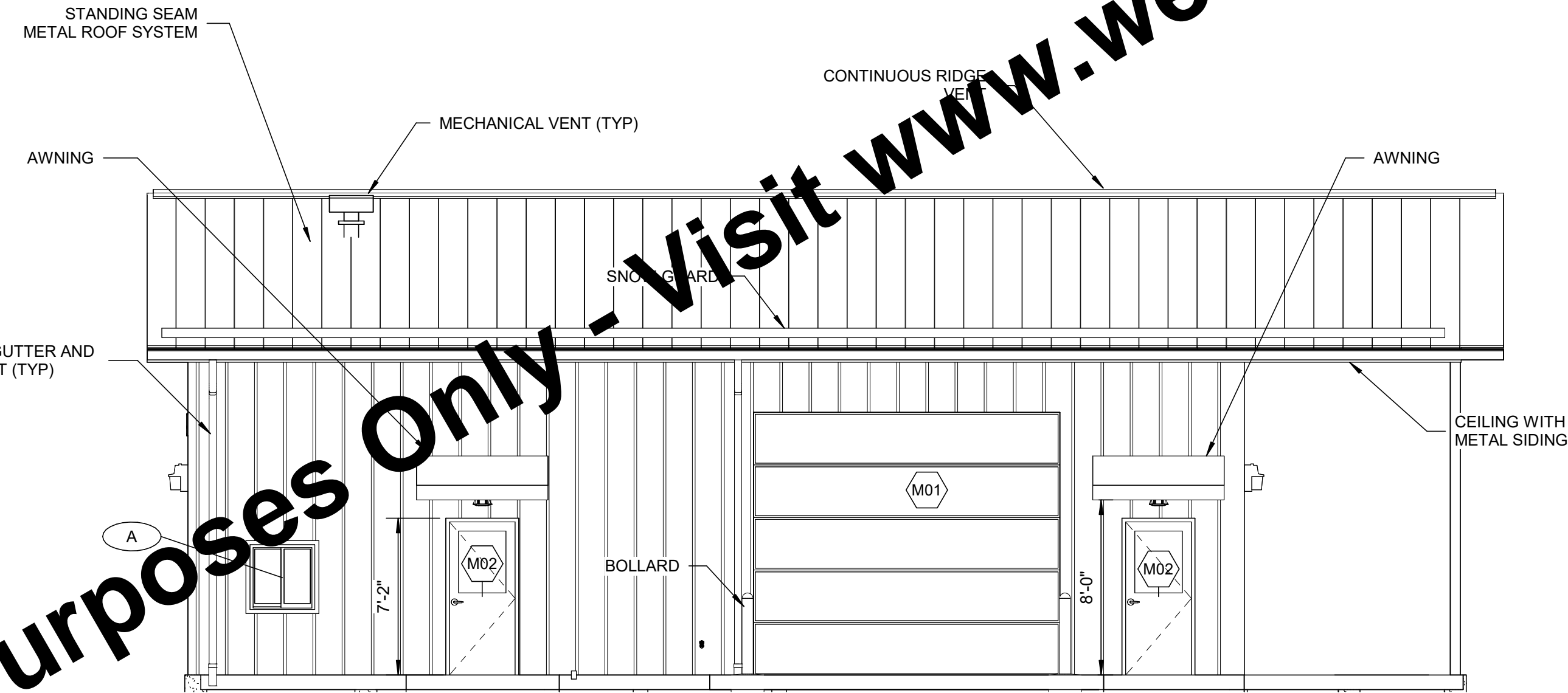

**EAST ELEVATION**  
SCALE: 3/16" = 1'-0"

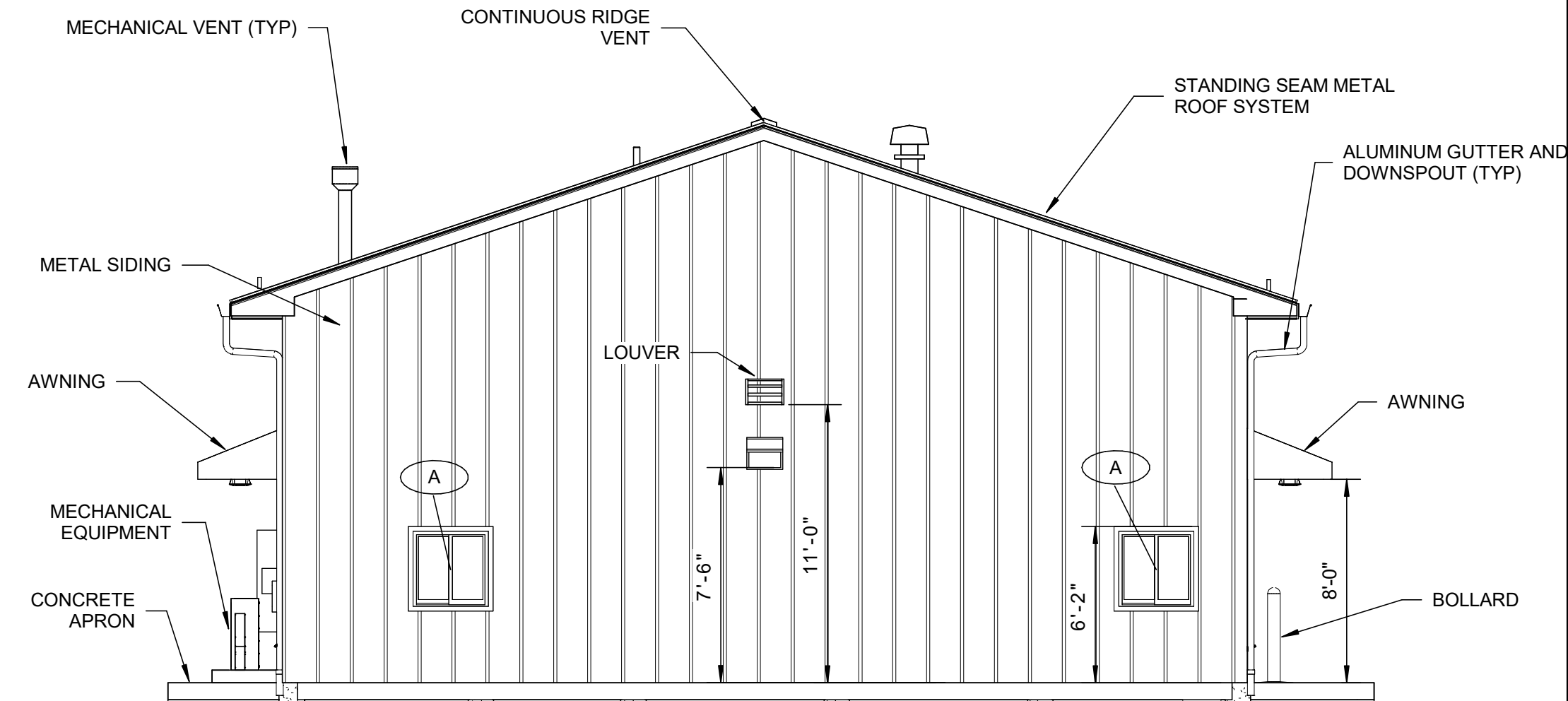

**SOUTH ELEVATION**  
SCALE: 3/16" = 1'-0"

For Viewing Purposes Only - Visit [www.wesslerengineering.com](http://www.wesslerengineering.com) to Purchase

Plotted: 1/22/2026 8:24:51 AM C:\Autodesk\Revit Local\703222\MB-NEW-VENT-R25\_CurtisGraham.rvt

SCALE VERIFICATION  BAR IS ONE INCH LONG ON ORIGINAL DRAWING	DRAWN BY	CLG	NO.	DATE	INITIALS	REVISION DESCRIPTION
	CHECKED BY	MAP				
	APPROVED BY	AMS				
	ISSUE DATE					
	FEBRUARY 2026					
PROJECT NUMBER						
703222-04-001						

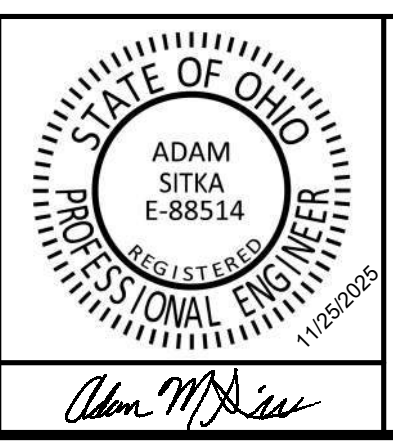

**WATER SYSTEM IMPROVEMENTS**  
CONTRACT B NEW BOOSTER STATION AND TREATMENT PLANT IMPROVEMENTS  
VILLAGE OF HOLGATE, OHIO

**NEW WATER TREATMENT BUILDING ELEVATIONS**

SHEET NO.  
**4A2**

PAGE NUMBER  
**22**

DDAGW-4113  
02/25/2026



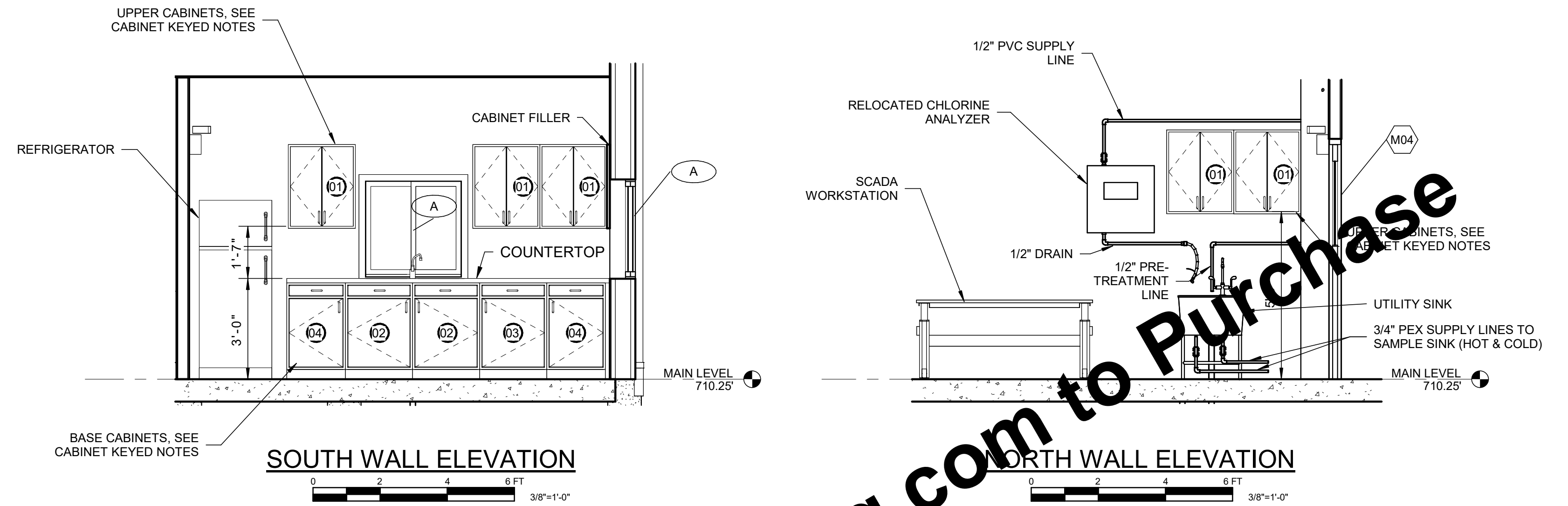

- CABINET KEYED NOTES**
- 01 24"W X 12"D X 35 3/4"H BASE CABINET W/ 2 DOOR AND 1 ADJ. SHELF
  - 02 48"W X 24"D X 35 3/4"H BASE SINK CABINET W/ 2 DOOR AND S.S. STAINLESS STEEL BOWL SINK
  - 03 24"W X 24"D X 35 3/4"H BASE CABINET W/ 1 DOOR AND 1 ADJ. SHELF
  - 04 21"W X 24"D X 35 3/4"H BASE CABINET W/1 DOOR AND 1 ADJ. SHELF

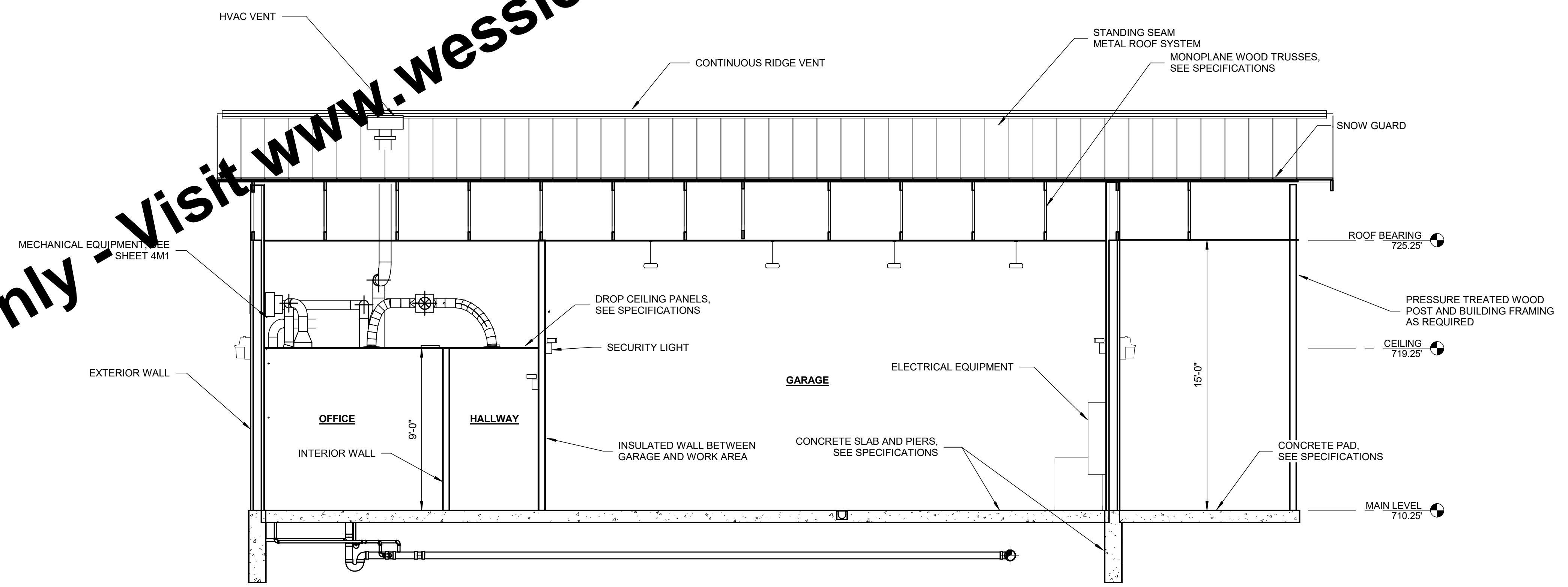

For Viewing Purposes Only - Visit [www.wesslerengineering.com](http://www.wesslerengineering.com) to Purchase

SCALE VERIFICATION	DRAWN BY	CLG	NO.	DATE	INITIALS	REVISION DESCRIPTION	
BAR IS ONE INCH LONG ON ORIGINAL DRAWING 	CHECKED BY	MAP					
	APPROVED BY	AMS					
	ISSUE DATE						
	FEBRUARY 2026						
PROJECT NUMBER							
703222-04-001							

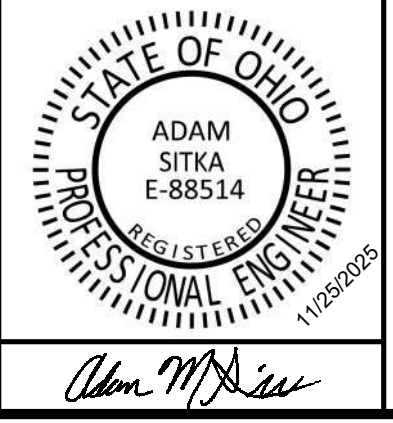

**WATER SYSTEM IMPROVEMENTS**  
 CONTRACT B NEW BOOSTER STATION AND TREATMENT PLANT IMPROVEMENTS  
 VILLAGE OF HOLGATE, OHIO

**NEW WATER TREATMENT BUILDING**  
**SECTION AND ELEVATIONS**

SHEET NO.  
**4A3**

PAGE NUMBER  
**23**

DDAGW-4113  
 02/25/2026



Plotted: 1/22/2026 8:26:20 AM C:\Autodesk\Revit Local\703222-MB-NEW-CENT-R25\_CurtisGramann.rvt



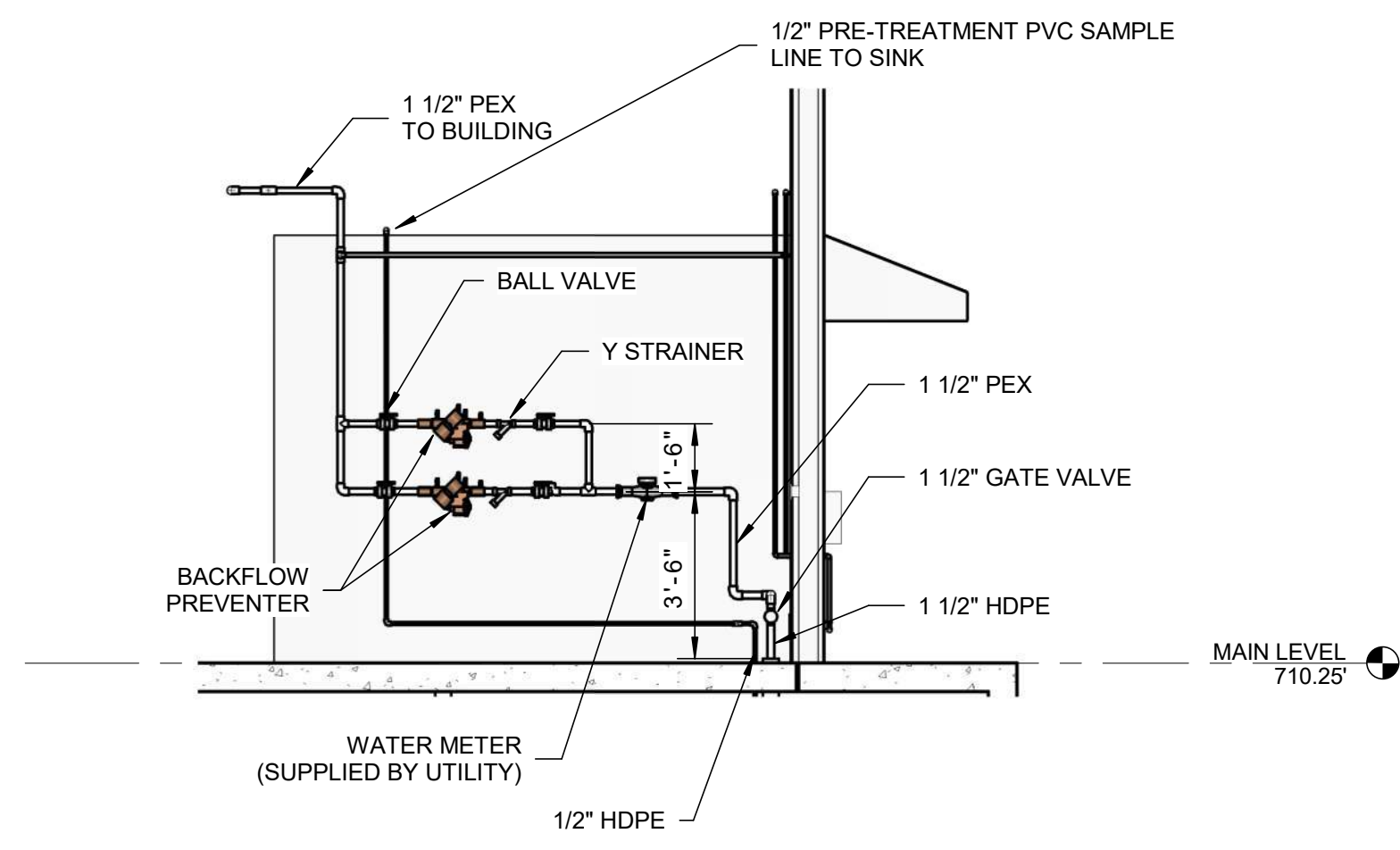

**WATER ENT. SECTION**  
 0 2 4 8 FT  
 1/4"=1'-0"

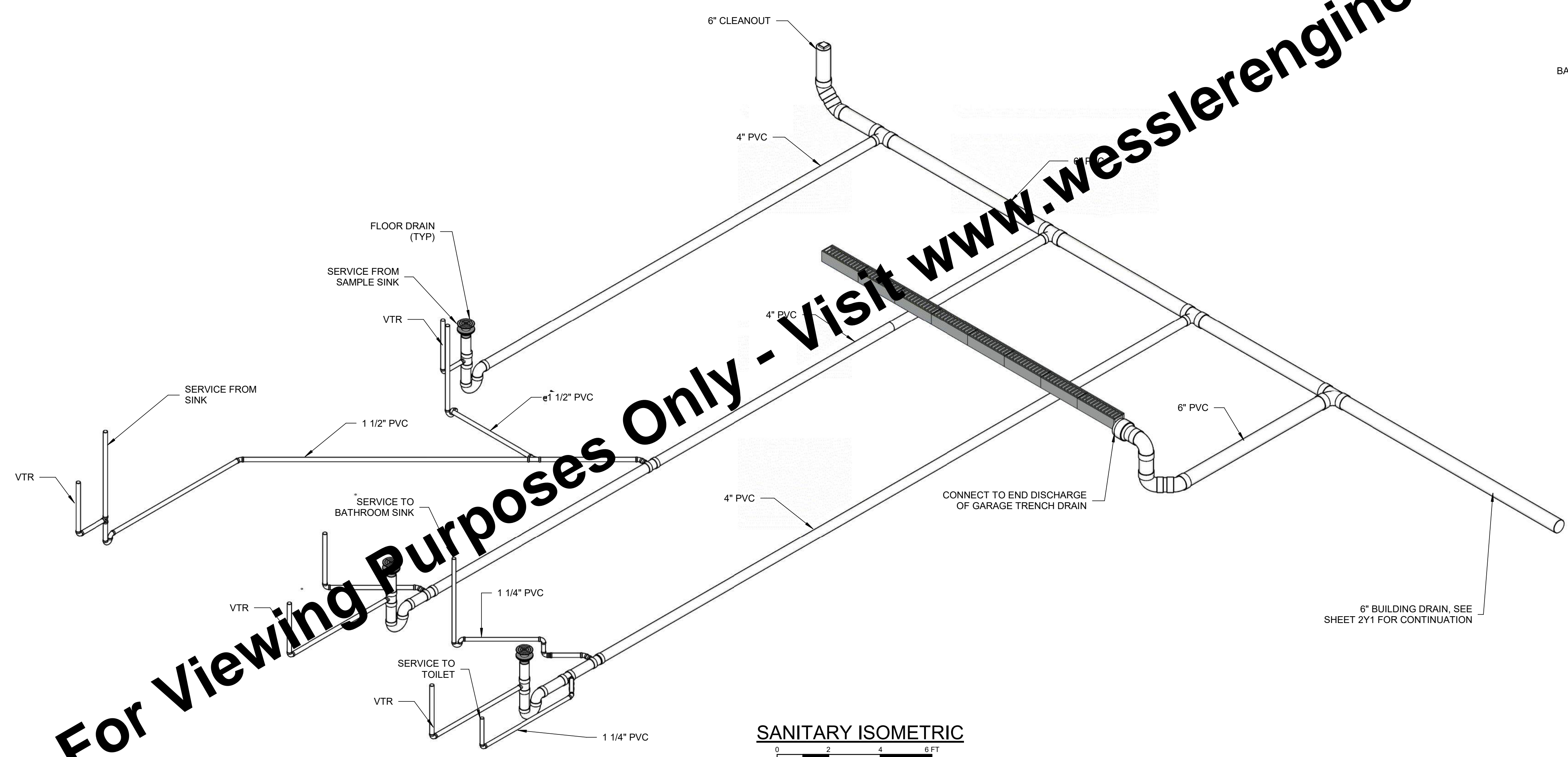

**SANITARY ISOMETRIC**  
 0 2 4 6 FT  
 3/8"=1'-0"

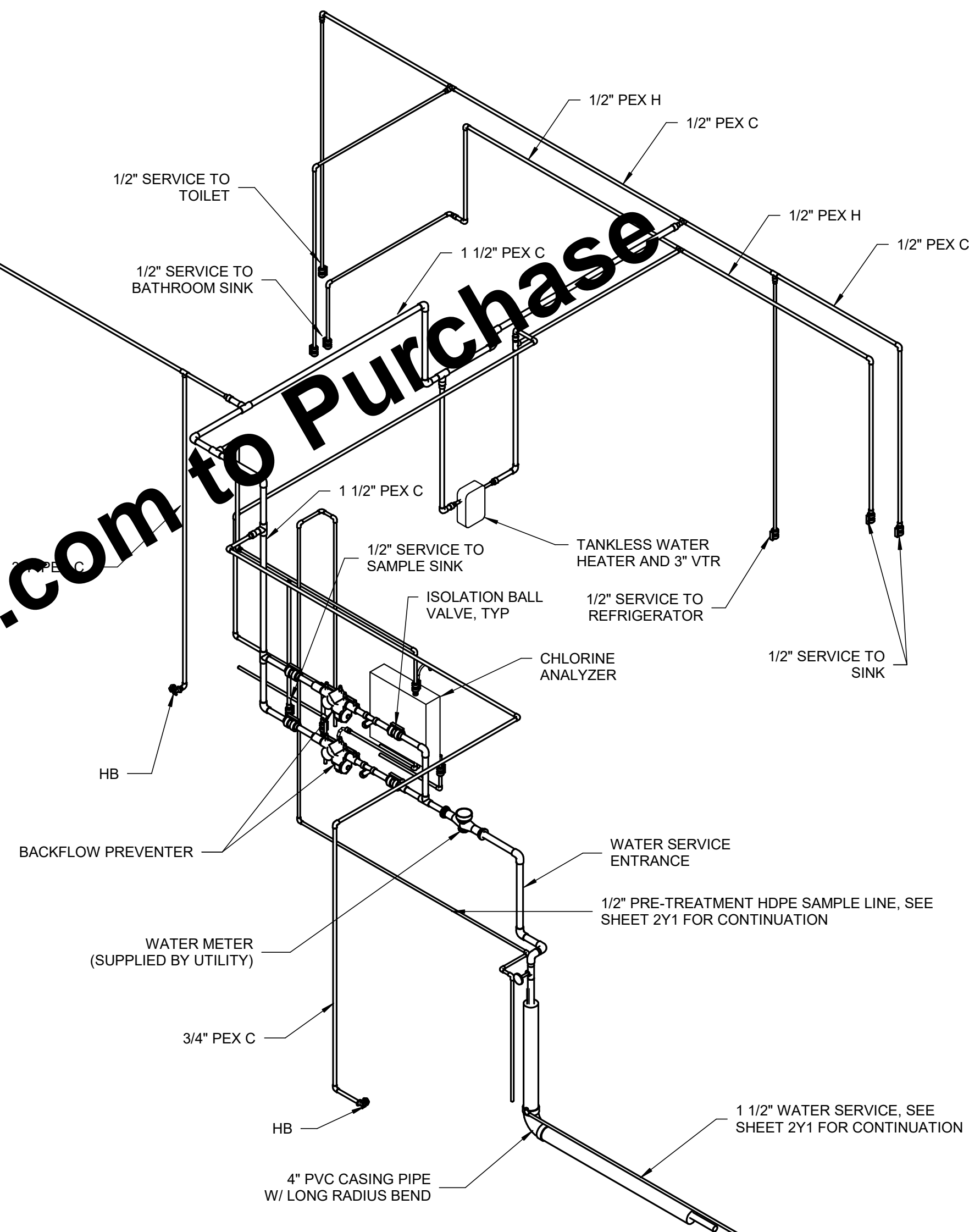

**WATER ISOMETRIC**  
 0 2 4 6 FT  
 3/8"=1'-0"

- LEGEND**
- TRUE UNION BALL VALVE
  - PRESSURE GAUGE
  - CHECK VALVE
  - FLOW GAUGE

**PLUMBING LEGEND**  
 SCALE: NONE

For Viewing Purposes Only - Visit [www.wesslerengineering.com](http://www.wesslerengineering.com) to Purchase

Plotted: 1/22/2026 8:31:32 AM C:\Autodesk\Revit Local\703222-MB-NEW-GEN-PCS-CurtisGramann.rvt

SCALE VERIFICATION	DRAWN BY	CLG	NO.	DATE	INITIALS	REVISION DESCRIPTION
BAR IS ONE INCH LONG ON ORIGINAL DRAWING	CHECKED BY	MAP				
	APPROVED BY	AMS				
	ISSUE DATE	FEBRUARY 2026				
	PROJECT NUMBER	703222-04-001				

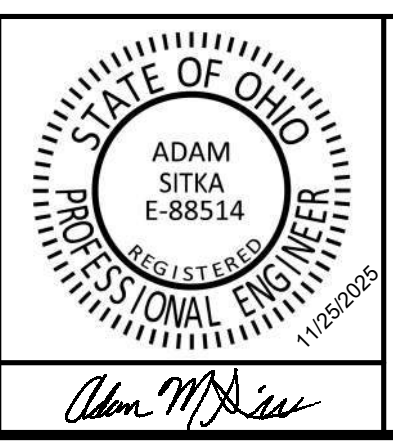

**WATER SYSTEM IMPROVEMENTS**  
 CONTRACT B NEW BOOSTER STATION AND TREATMENT PLANT IMPROVEMENTS  
 VILLAGE OF HOLGATE, OHIO

**NEW WATER TREATMENT BUILDING**  
**PLUMBING ISOMETRICS**

SHEET NO.  
**4P2**

PAGE NUMBER  
**25**

DDAGW-4113  
 02/25/2026



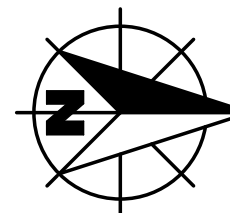

**GENERAL NOTES:**

- REFER TO SHEET 1M1 MECHANICAL SYMBOLS AND NOTATION FOR ADDITIONAL REQUIREMENTS.
- INSULATE DUCTWORK BETWEEN EXTERIOR WALL/ROOF AND MOTORIZED ISOLATION DAMPERS.
- HVAC DESIGN AIRWAYS WALLS DO NOT GO TO DECK. IF PRE-ENGINEERED BUILDING WALLS GO TO DECK, THEN COORDINATE WITH ARCHITECT FOR OPENINGS ABOVE CEILING WITH ENGINEER.
- COORDINATE FINAL LOCATION OF CONDENSING UNIT WITH ELECTRICAL ENGINEER. DESIGN INTENT IS TO USE 70 FT. MANUFACTURED LINE SET.

**KEYED NOTES:** #

- MANUFACTURER'S RECOMMENDED TERMINATION DEVICE.
- MANUFACTURER'S RECOMMENDED CONCENTRIC VENT KIT.
- 8"Ø UP TO RRV-1. TRANSITION IN RISE TO CONNECTIONS AT HOOD. INSULATE DUCT FROM DAMPERS TO ROOF. REFER TO 3/4M1 FOR ADDITIONAL INFORMATION.
- SLOPED CURB, FINISH COLOR BY OWNER. REFER TO SCHEDULE.
- WALL MOUNT ERV, BOTTOM AT 4'6" A.F.F.
- INSULATE OUTDOOR AIR DUCT FROM EXTERIOR WALL TO ERV.
- MOUNT INDOOR UNIT ON 6" HOUSEKEEPING PAD THAT EXTENDS BEYOND EQUIPMENT BY 6" AS SHOWN.
- MOUNT OUTDOOR UNIT ON 8" HOUSEKEEPING PAD, TOP AT 4" ABOVE GRADE, MINIMUM 6" WIDER THAN UNIT IN EACH DIRECTION.
- INSULATE SUPPLY AIR DUCT FROM ERV TO CONNECTION AT RETURN AIR DUCT.
- MOUNT BOTTOM OF PROPELLER UNIT HEATER AT 11'-6" A.F.F. PROVIDE CLOSED COMBUSTION COMBINATION FLUE/VENT SYSTEM IN ACCORDANCE WITH MFG'S RECOMMENDATIONS.
- MOUNT BOTTOM OF UNIT HEATER AT 12" A.F.F.
- COORDINATE REFRIGERANT PIPE ROUTING WITH PLUMBING PIPING (NOT SHOWN), REFER TO SHEET 4P1. COVER ALL PIPE INSULATION WITHIN 8 FEET OF FLOOR IN GARAGE SPACE WITH PVC JACKETING.
- WATER HEATER 5" COMBINATION VENT/COMBUSTION AIR DUCTWORK UP THROUGH ROOF IN ACCORDANCE WITH MFG'S RECOMMENDATIONS.
- PROVIDE DUCT TRIM COLLAR AT EACH DUCT / FLUE PENETRATION OF CEILING AND ESCUTCHEON AT EACH PIPE PENETRATION.

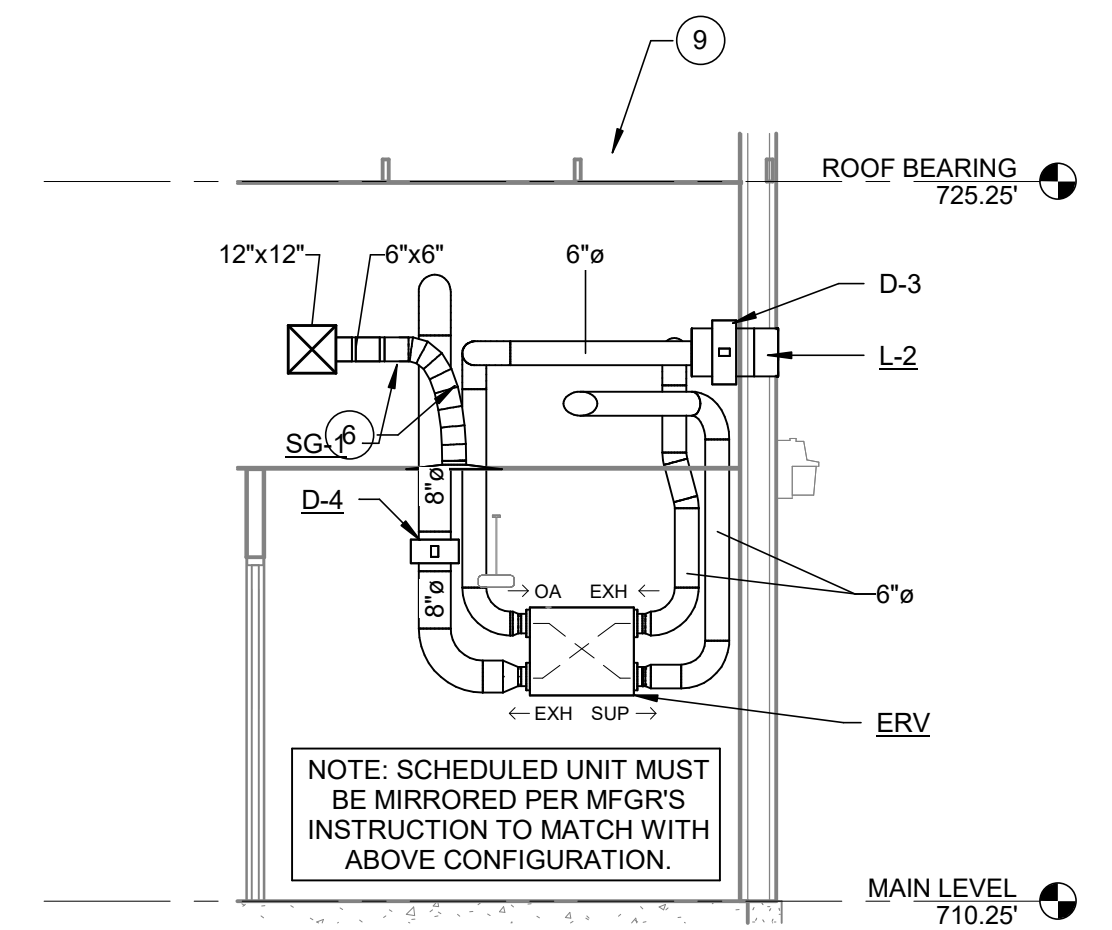

**UTILITY ROOM - ERV** 2  
4M1  
0 2 4 8 FT  
1/4"=1'-0"

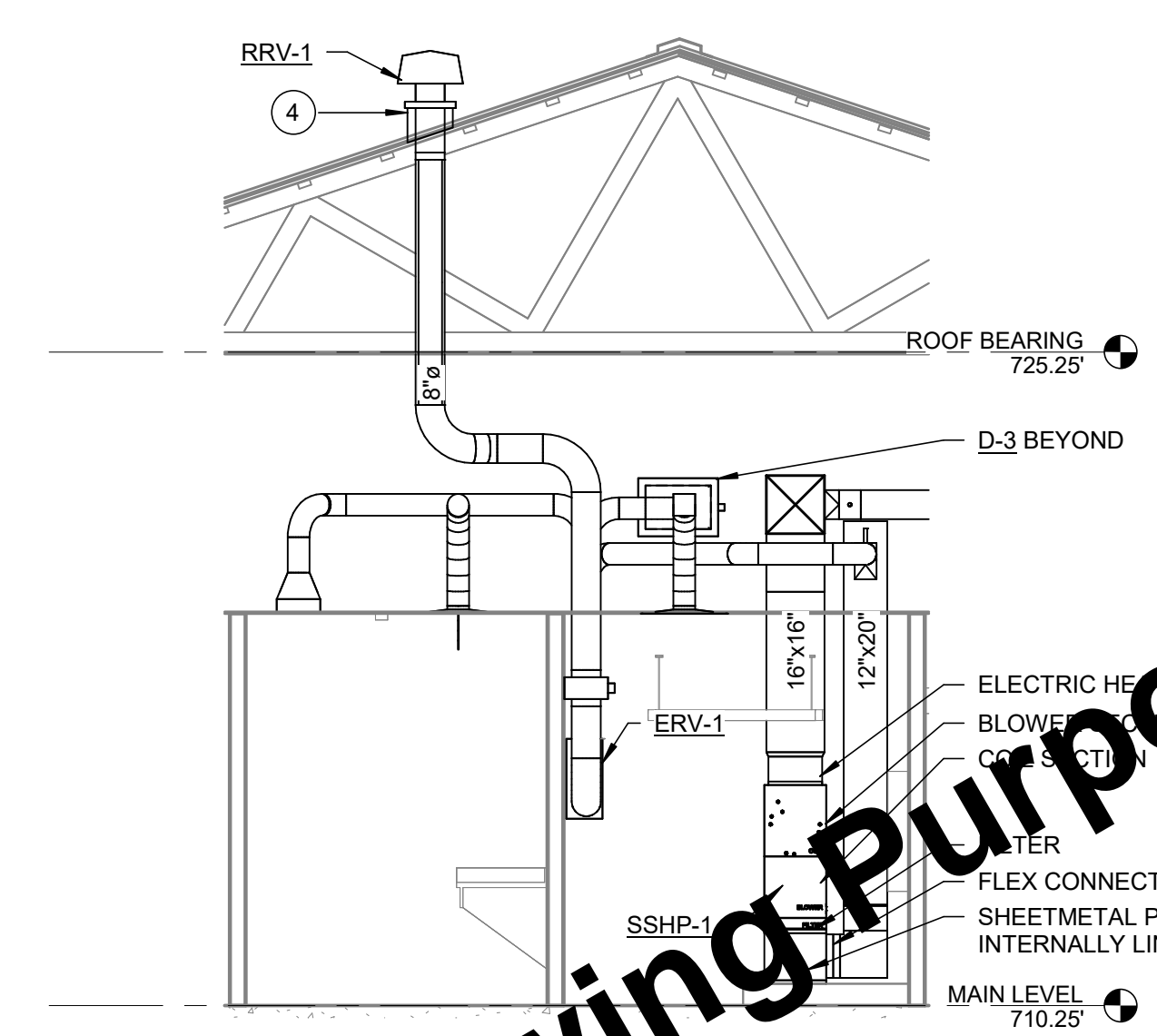

**UTILITY ROOM - FURNACE** 3  
4M1  
0 2 4 8 FT  
1/4"=1'-0"

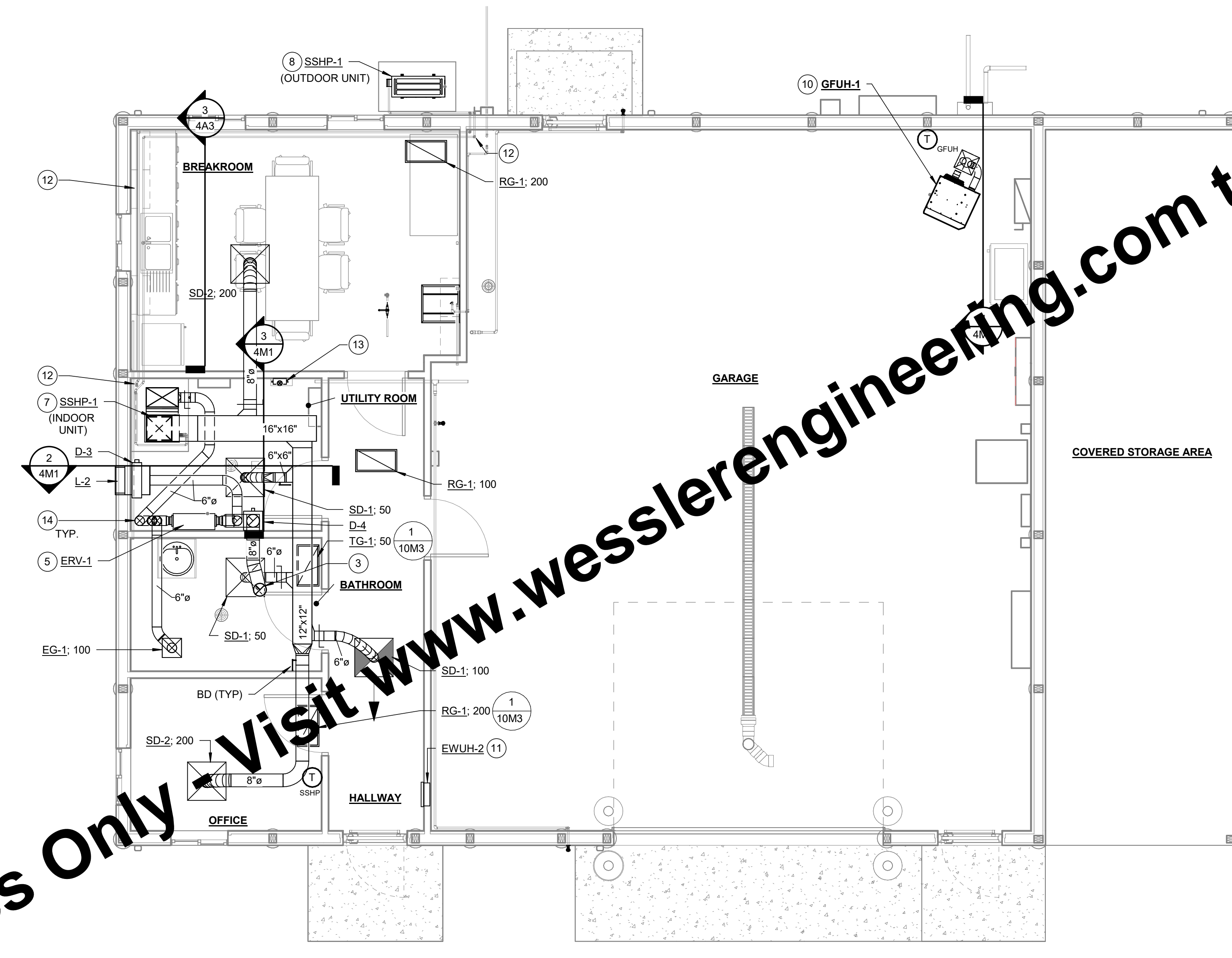

**HVAC PLAN**  
0 2 4 8 FT  
1/4"=1'-0"

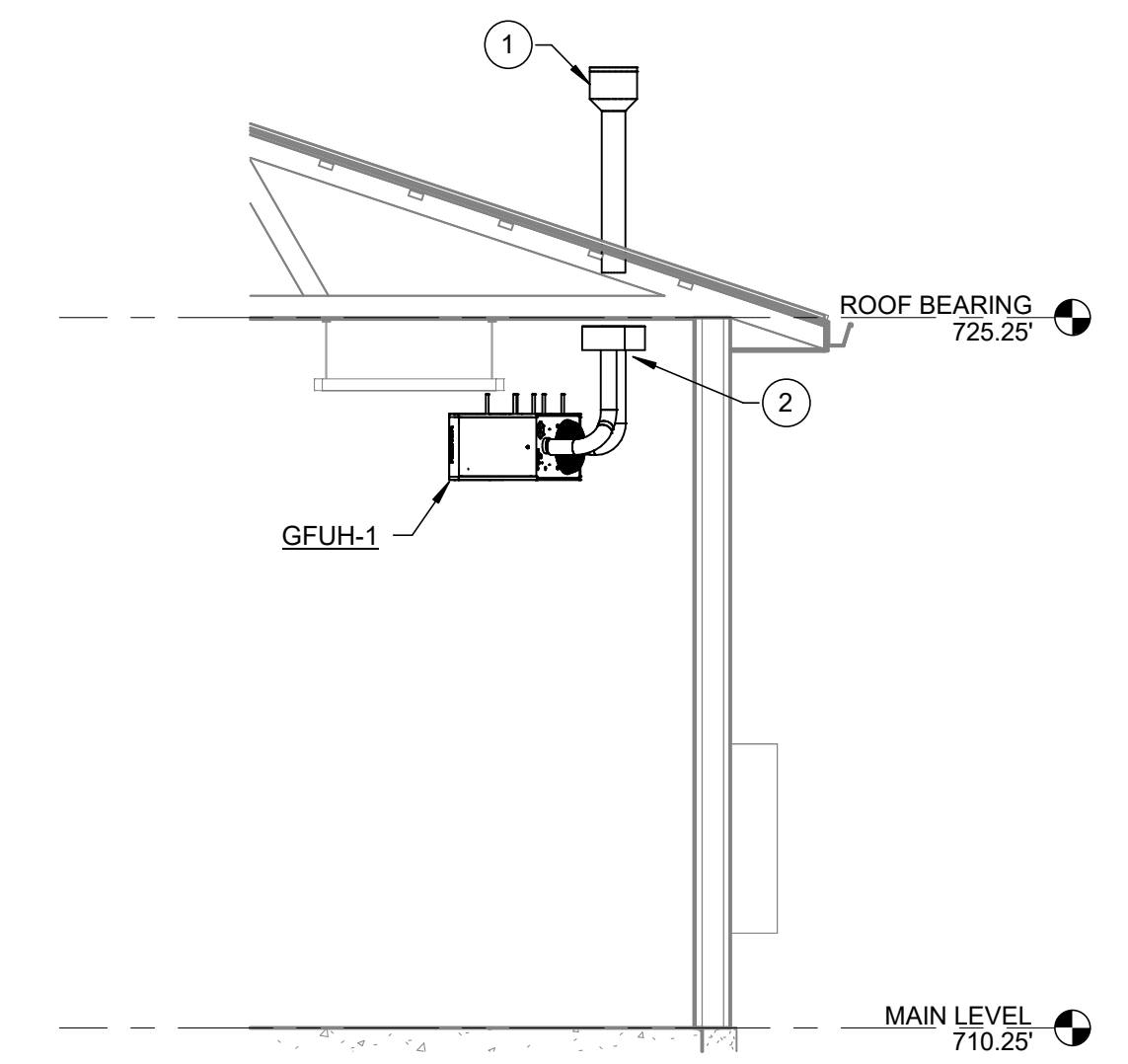

**SECTION AT GFUH-1** 4  
4M1  
0 2 4 8 FT  
1/4"=1'-0"

For Viewing Purposes Only - Visit [www.wesslerengineering.com](http://www.wesslerengineering.com) to Purchase

Plotted: 1/22/2026 8:27:12 AM C:\Autodesk\Revit Local\703222-MB-NEW-CENT-R25\_CurtisGraham.rvt

SCALE VERIFICATION	DRAWN BY	CLG	NO.	DATE	INITIALS	REVISION DESCRIPTION
BAR IS ONE INCH LONG ON ORIGINAL DRAWING	CHECKED BY	SPR				
	APPROVED BY	WCM				
	ISSUE DATE	FEBRUARY 2026				
	PROJECT NUMBER	703222-04-001				



**WATER SYSTEM IMPROVEMENTS**  
CONTRACT B NEW BOOSTER STATION AND TREATMENT PLANT IMPROVEMENTS  
VILLAGE OF HOLGATE, OHIO

**NEW WATER TREATMENT BUILDING**  
**HVAC PLAN AND SECTIONS**

SHEET NO.  
**4M1**

PAGE NUMBER  
**26**

DDAGW-4113  
02/25/2026



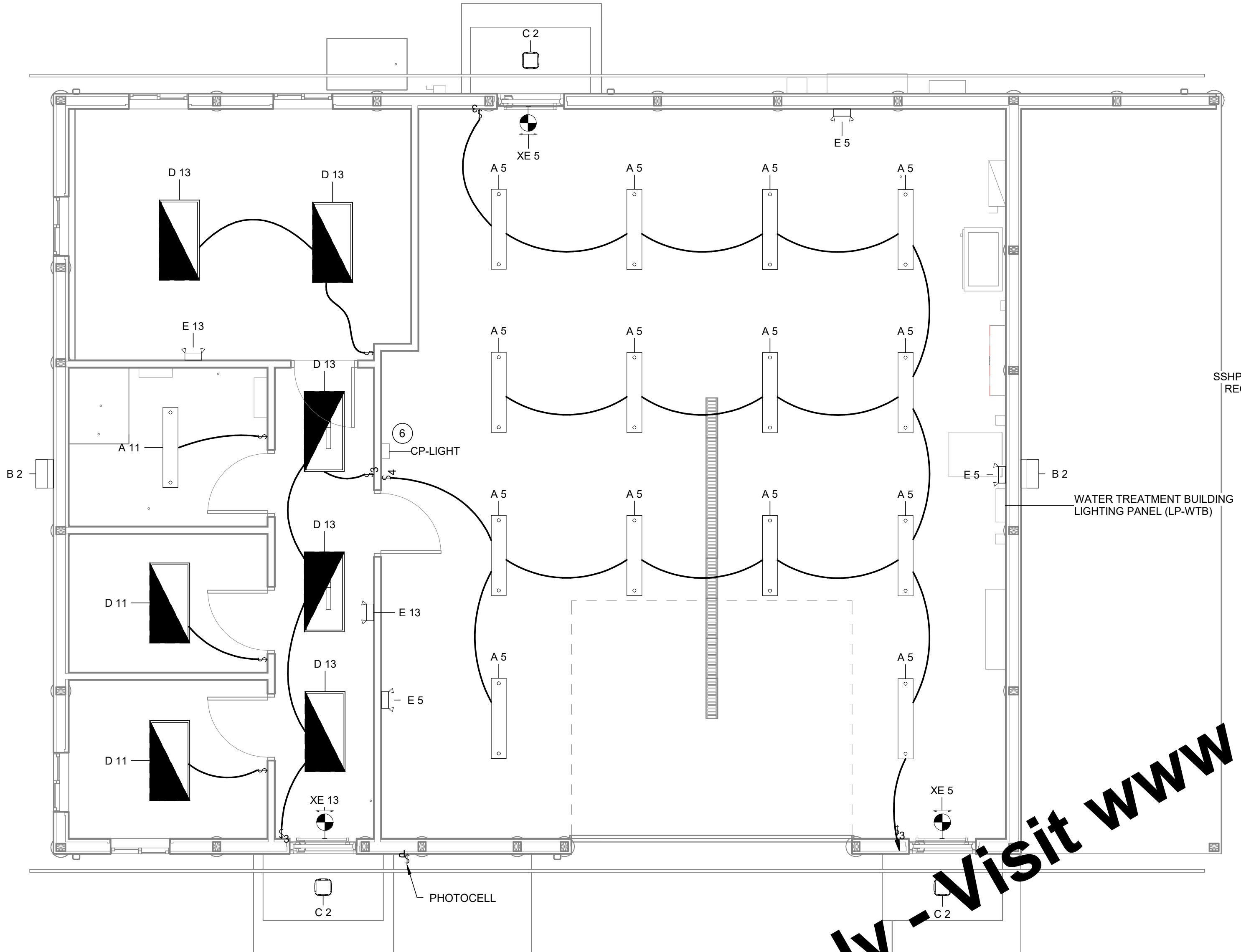
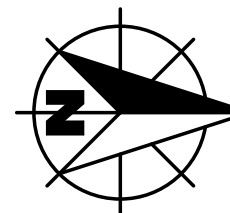

LIGHTING PLAN  
0 2 4 8 FT  
1/4"=1'-0"

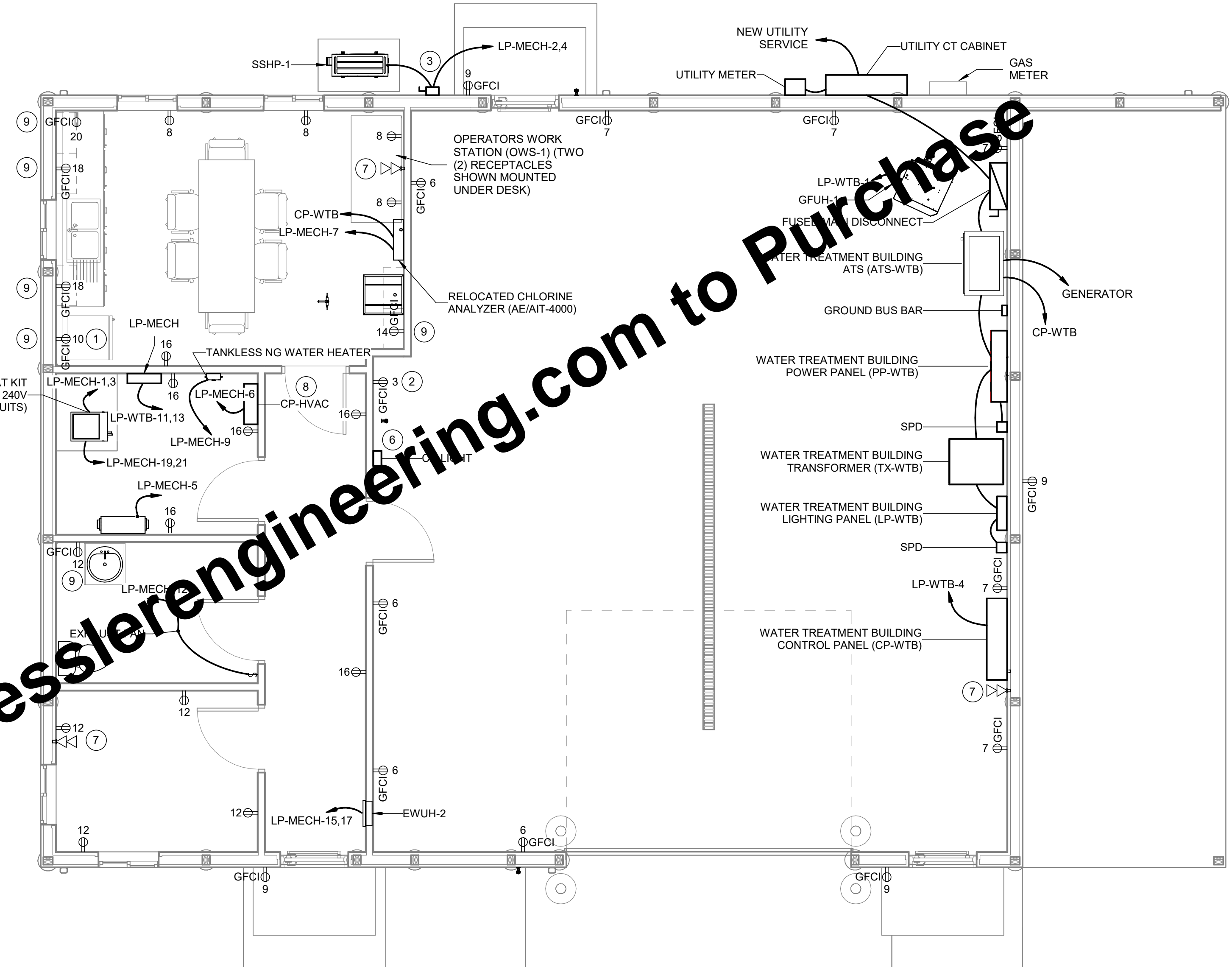

POWER PLAN  
0 2 4 8 FT  
1/4"=1'-0"

For Viewing Purposes Only - Visit [www.wesslerengineering.com](http://www.wesslerengineering.com) to Purchase

**KEYED NOTES:** #

1. DEDICATED RECEPTACLE FOR REFRIGERATOR. RECEPTACLE SHALL BE ON ITS OWN DEDICATED CIRCUIT AS SHOWN.
2. DEDICATED RECEPTACLE FOR FUTURE EQUIPMENT. RECEPTACLE SHALL BE ON ITS OWN DEDICATED CIRCUIT AS SHOWN.
3. 240V, 2P, 30A, NEMA4X S.S., NON-FUSIBLE DISCONNECT SWITCH
4. 240V, 2P, 60A, NEMA1, NON-FUSIBLE DISCONNECT SWITCH
5. 240V, 2P, 30A, NEMA1, NON-FUSIBLE DISCONNECT SWITCH
6. CP-LIGHT TO HAVE A SINGLE (1) HOA SWITCH FOR OUTDOOR LIGHTING CONTROL. HOA SWITCH SHALL CONTROL BOOSTER STATION OUTDOOR LIGHTING. HOA SWITCH WILL HAVE 3 POSITIONS. LIGHTS ON, LIGHTS OFF, LIGHTS AUTO (PHOTOCELL). SEE DETAIL ON SHEET 8E6.
7. ONE DATA DROP FOR CONNECTION FROM OWS-1 TO CP-WTB. ONE DATA DROP FOR CONNECTION TO FUTURE INTERNET SERVICE PROVIDER (ISP).
8. PROVIDE CONDUIT, WIRE, RELAYS AND OTHER EQUIPMENT TO PROPERLY INTERLOCK THE ERV, HEAT PUMP, OCCUPANCY SENSORS, AND THERMOSTAT TIMER. WIRING MUST MATCH THE SEQUENCES OF CONTROL DETAILED ON SHEET 10M3.
9. RECEPTACLE SHALL BE MOUNTED ABOVE COUNTER SPACE.

**GENERAL NOTES:**

1. ALL OUTDOOR RECEPTACLES SHALL BE 20A GFCI PROTECTED AND PROVIDED WITH IN-USE COVERS.
2. NOTE THAT THERE ARE TWO LIGHTING PANELBOARDS. LP-WTB AND LP-MECH. LP-MECH FEEDS LOADS ON THE SOUTH SIDE OF THE BUILDING. LP-WTP FEEDS EVERYTHING ELSE. CONFIRM CIRCUIT NUMBERS WITH PANEL SCHEDULES

Plotted: 1/22/2026 8:32:29 AM C:\Autodesk\Revit Local\703222-MB-NEW-CENT-R25\_CurtisGraham.rvt

SCALE VERIFICATION	DRAWN BY	JLK	NO.	DATE	INITIALS	REVISION DESCRIPTION
BAR IS ONE INCH LONG ON ORIGINAL DRAWING 	CHECKED BY	JAP				
	APPROVED BY	WCM				
	ISSUE DATE	FEBRUARY 2026				
	PROJECT NUMBER	703222-04-001				

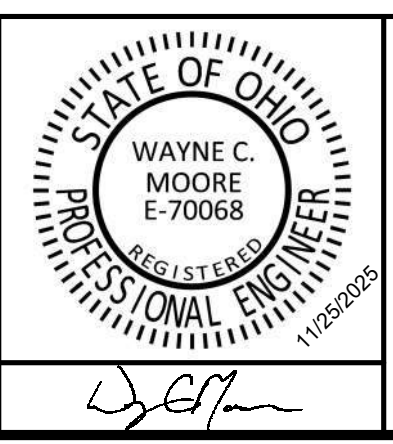

**WATER SYSTEM IMPROVEMENTS**  
CONTRACT B NEW BOOSTER STATION AND TREATMENT PLANT IMPROVEMENTS  
VILLAGE OF HOLGATE, OHIO

**NEW WATER TREATMENT BUILDING**  
**POWER AND LIGHTING PLAN**

SHEET NO.  
**4E1**

PAGE NUMBER  
**27**

DDAGW-4113  
02/25/2026



**GENERAL NOTES:**

- GROUND STORAGE TANK REHABILITATION WORK IS DESCRIBED IN FURTHER DETAIL IN SPECIFICATIONS. SEE SECTION 13211

**NOTES:**

- WATER SURFACE ELEVATIONS ARE BASED ON HISTORIC DRAWINGS. SETPOINTS SHALL BE BASED ON LEVEL RATHER THAN ELEVATIONS.
- MINIMUM WATER LEVEL REFERS TO THE MINIMUM LEVEL AT WHICH THE MIXER CAN OPERATE; MIXER WILL TURN OFF IF WATER LEVEL FALLS BELOW THIS LEVEL.
- HIGH AND LOW WATER LEVELS ARE SET POINTS THAT CAN BE CHANGED BY OPERATORS AND WILL BE DETERMINED IN THE FIELD.
- SEE SPECIFICATION 13400 FOR A FULL CONTROL DESCRIPTION.

**KEYED NOTES** ○

- SEAL EXPOSED EXTERIOR FOUNDATION, SEE SPECIFICATION SECTION 13211
- INSTALL RED VALVE TF-2 CHECK VALVE AND PROVIDE 12" AIR GAP BETWEEN OVERFLOW PIPE AND PIPE TO SEWER
- REPLACE EXISTING LADDER WITH NEW OSHA COMPLIANT MIN. 16" INTERIOR WIDTH LADDER
- ADD NEW CABLE CLIMB SYSTEM
- ADD NEW SWING GATE AT ACCESS STANDOFF PLATFORM AND TOP WALKWAY
- CLEAN INTERIOR AND EXTERIOR TANK SURFACES, SEE SPECIFICATION SECTION 13211
- SPOT REPAIR TO COATING AND AROUND EXISTING BOLT HEADS WHERE NEEDED INTERIOR AND EXTERIOR
- SEAL EXISTING SEAMS
- REMOVE EXISTING LADDER SHIELD AND REINSTALL ON NEW LADDER
- NEW IXOM SN-10 AERATOR - REMOVE AND REPLACE ROOF VENT TO DROP IN PLACE THROUGH VENT OPENING
- NEW IXOM GS-9 MIXER - DROP IN PLACE THROUGH HATCH
- NEW IXOM F4 VENTILATION SYSTEM - ROOF MOUNTED, SEE CONNECTION DETAIL SHEET 7MD2
- NEW IXOM CONTROL PANELS
- NEW 8" SUPPLY LINE FROM NAPOLEON
- NEW 4" BUTTERFLY CONTROL VALVE AND ELECTRIC ACTUATOR BV-07 (VAULT)
- PRESSURE TRANSMITTER AND 4" MAGNETIC FLOW METER
- NEW 8" DUCTILE IRON WATER MAIN
- CUT OUT EXISTING 6" 90° BEND, NEW 6" X 6" MJ TEE, 6" X 8" MJ REDUCER AND (2) 6" MJ SLEEVES
- SUMP PIT WITH PERMANENT SUMP PUMP AND LEVEL FLOAT
- INSTALL SUBMERSIBLE GRIDBEE GS-9 MIXING SYSTEM OR APPROVED EQUAL PER SECTION 11330. MIXER INSTALLATION SHALL BE ON THE BOTTOM OF THE TANK WITH A MINIMUM 24" WATER DEPTH
- EFFLUENT PIPING MODIFICATIONS (INSIDE TANK)  
10" 90° FLANGED DI BEND, FIELD FLANGE, 20 LF OF 10" DI FLANGE PIPE, 45° FLANGED DI BEND, AND PIPE STANDS

**LEGEND**

- EXISTING FEATURES
- NEW FEATURES

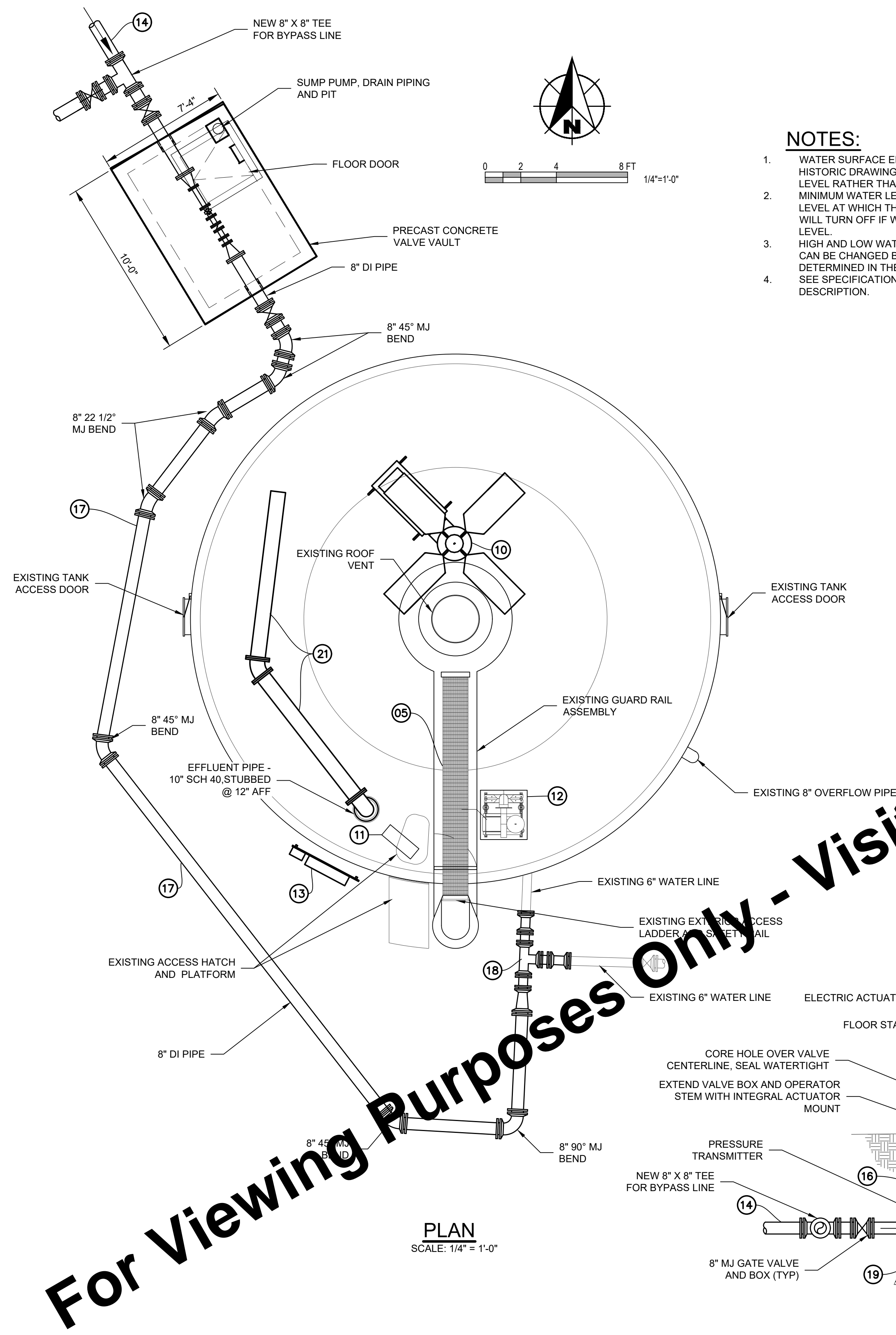

**PLAN**  
SCALE: 1/4" = 1'-0"

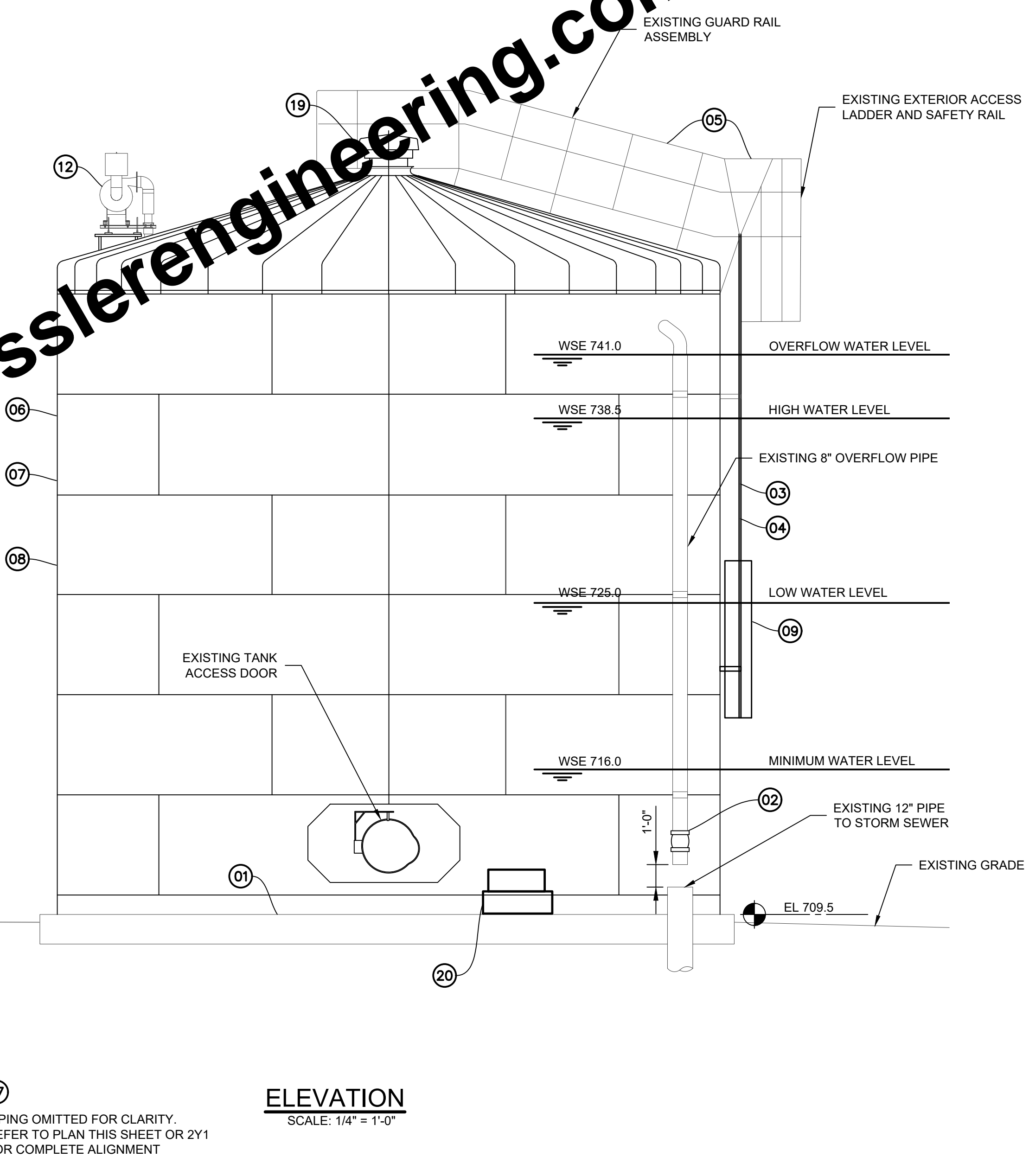

**ELEVATION**  
SCALE: 1/4" = 1'-0"

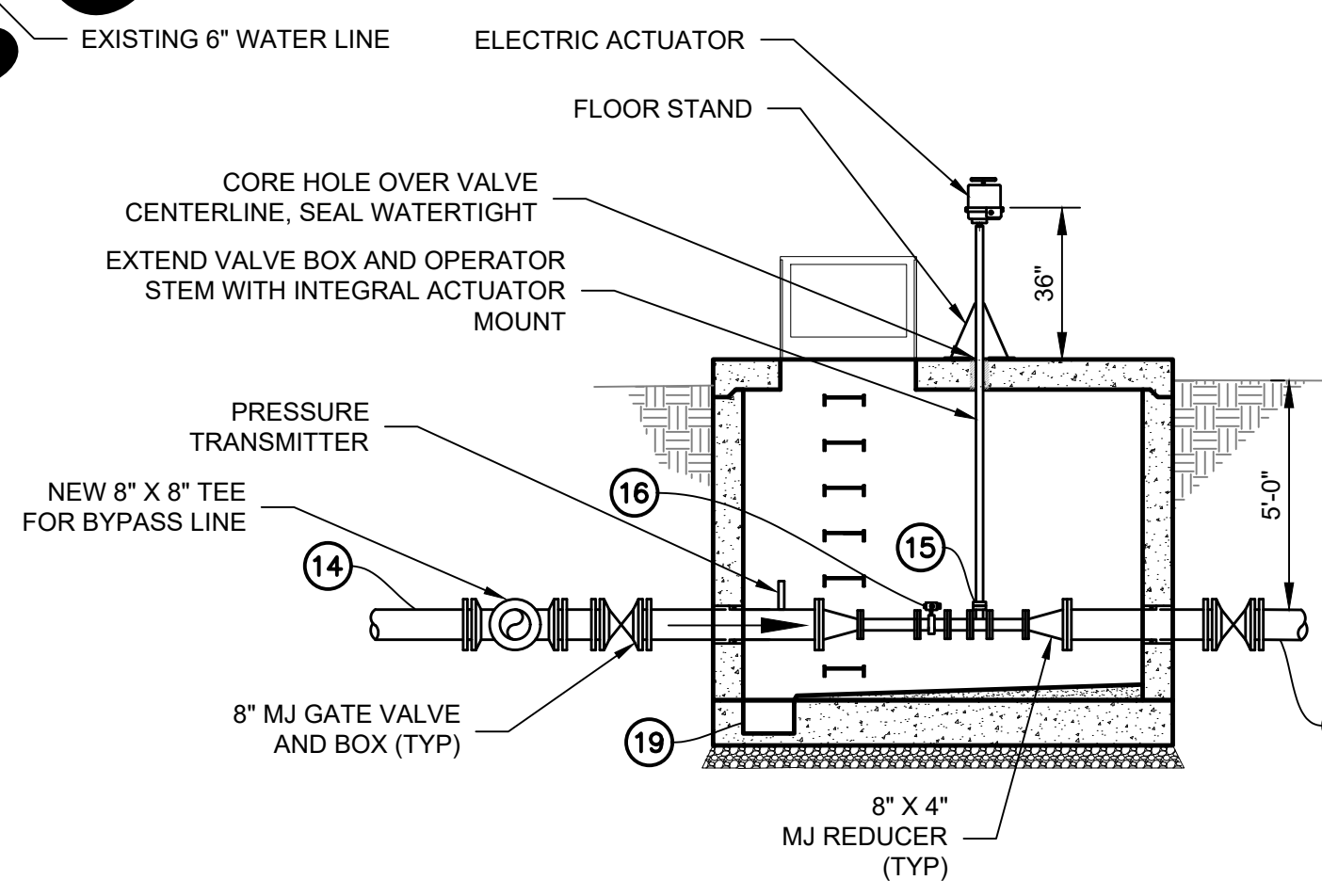

PIPING OMITTED FOR CLARITY. REFER TO PLAN THIS SHEET OR 2Y1 FOR COMPLETE ALIGNMENT

For Viewing Purposes Only - Visit [www.wesslerengineering.com](http://www.wesslerengineering.com) to Purchase

SCALE VERIFICATION	DRAWN BY	CLG	NO.	DATE	INITIALS	REVISION DESCRIPTIONS
BAR IS ONE INCH LONG ON ORIGINAL DRAWING	CHECKED BY	MAP				
	APPROVED BY	AMS				
	ISSUE DATE	FEBRUARY 2026				
	PROJECT NUMBER	703222-04-001				

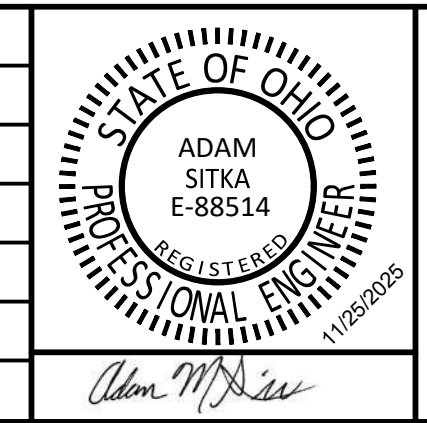

**WATER SYSTEM IMPROVEMENTS**

CONTRACT B NEW BOOSTER STATION AND WATER TREATMENT PLANT IMPROVEMENTS  
VILLAGE OF HOLGATE, OHIO

**EXISTING GROUND STORAGE TANK MODIFICATIONS**  
**PLAN AND ELEVATIONS**

SHEET NO.  
**5C1**

PAGE NO.  
**28**

DDAGW-4113  
02/23/2026

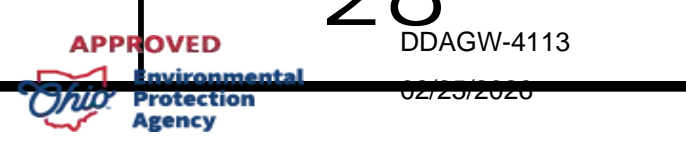

Drawing: X:\Holgeate\_OH\703222\_Holgeate\_WTP\DWG\Sheets\703222-EX-ST.dwg | Layout: 5C1 | Plotted: 01/29/26 @ 06:46:20 | L:\S:\S:\B:\C:\G

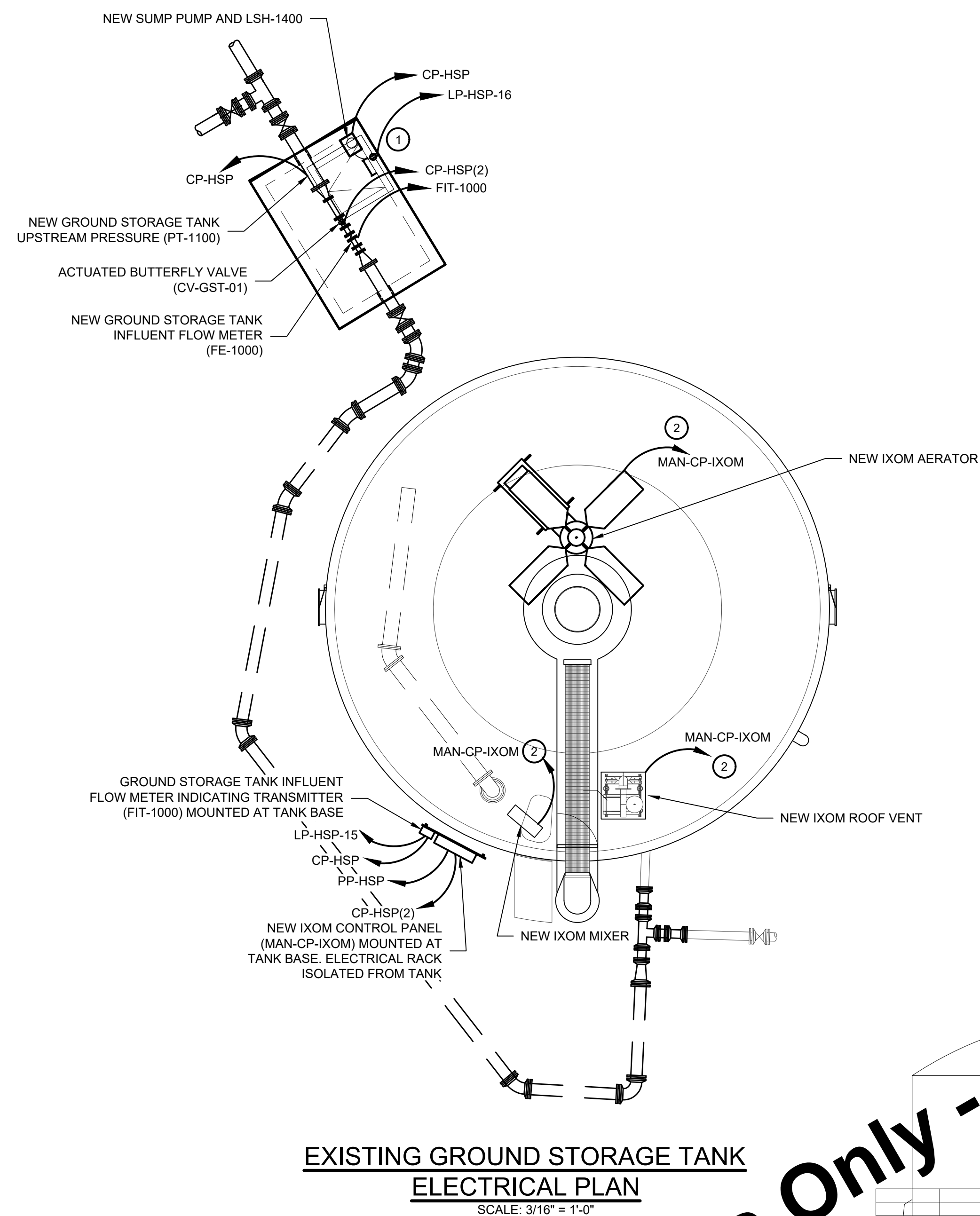
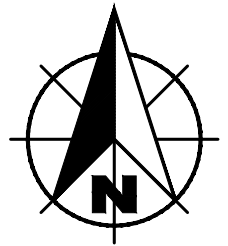

**EXISTING GROUND STORAGE TANK  
ELECTRICAL PLAN**  
SCALE: 3/16" = 1'-0"

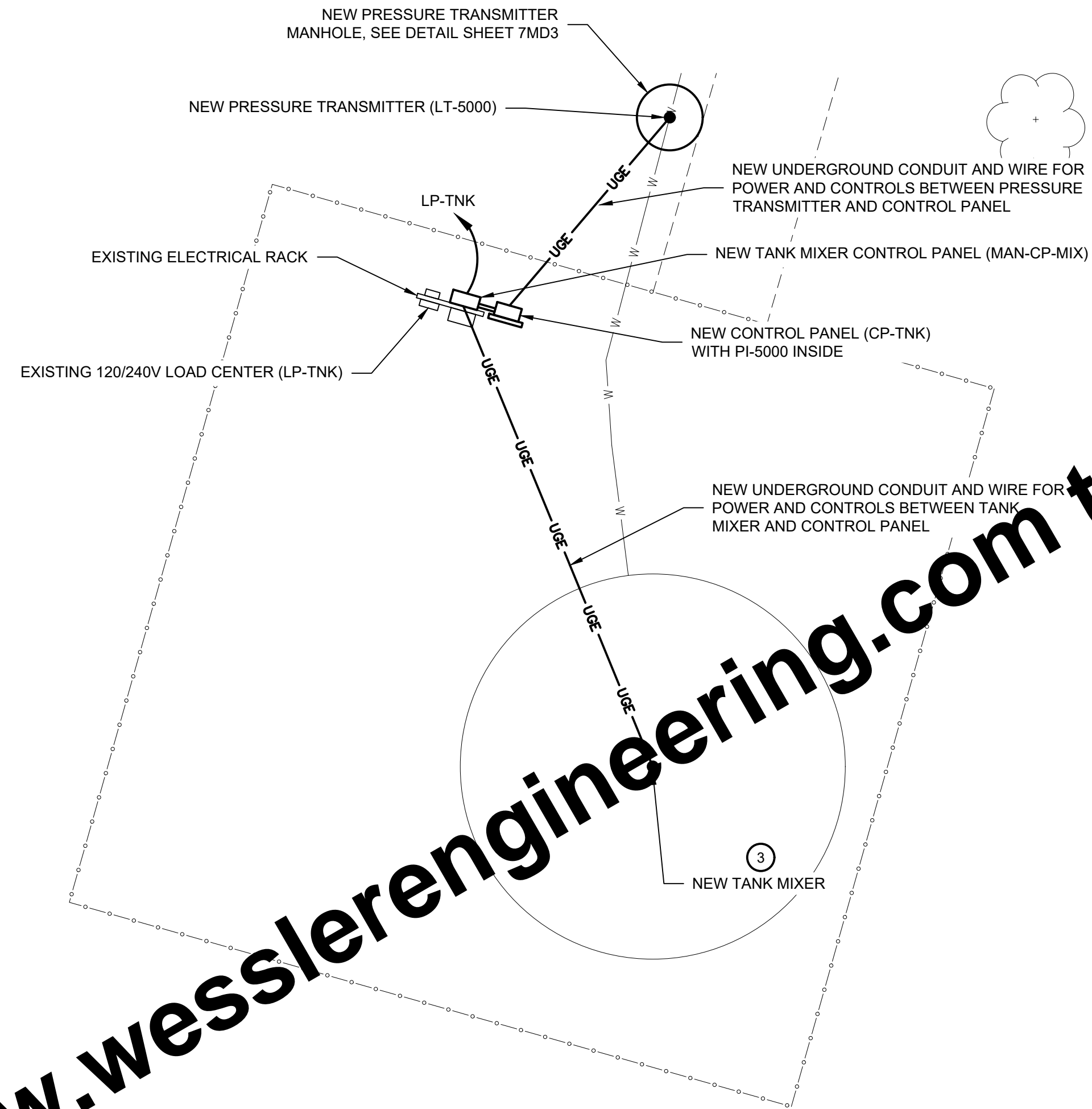

**EXISTING ELEVATED STORAGE TANK  
ELECTRICAL PLAN**  
SCALE: 1" = 30'

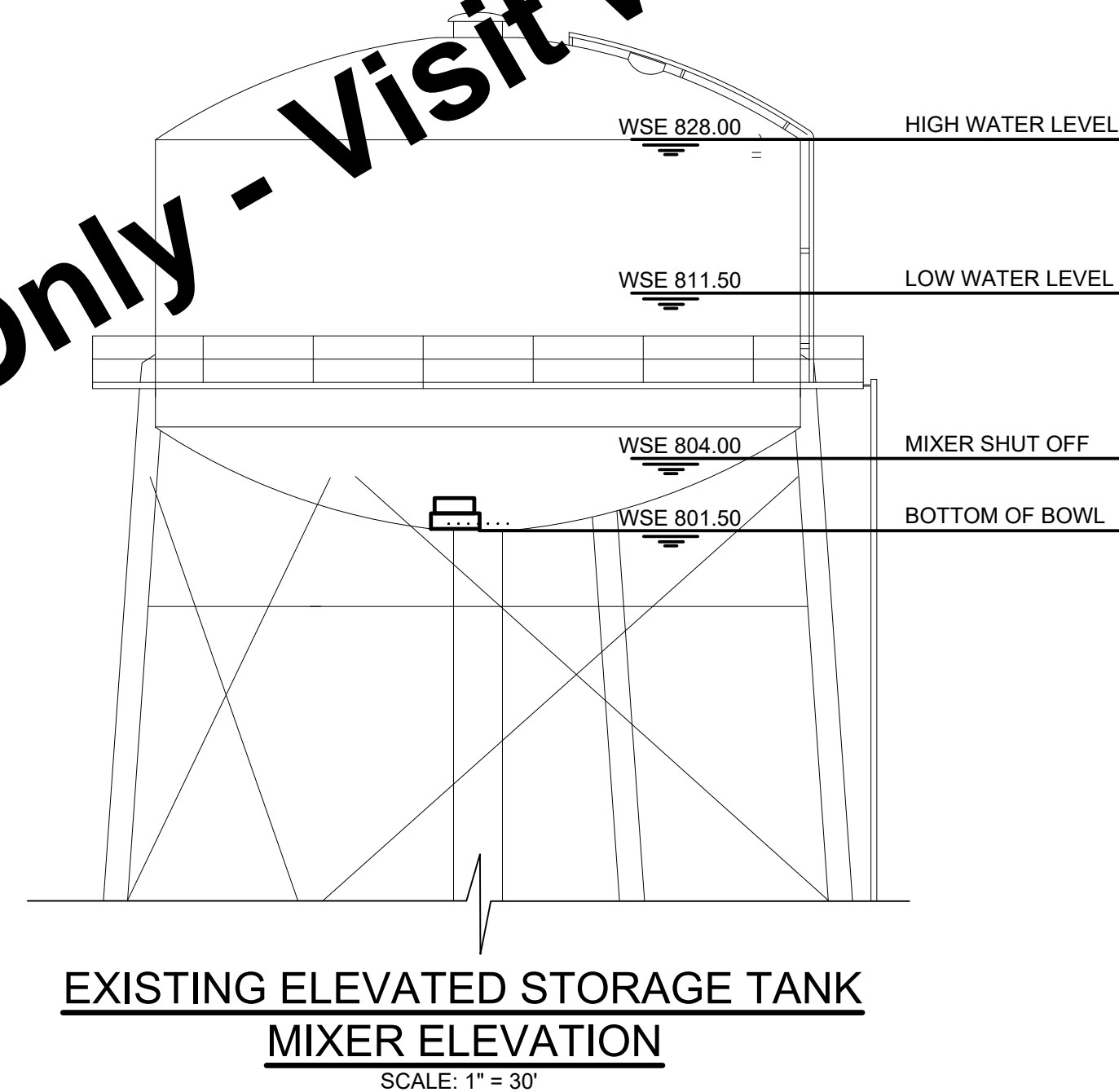

**EXISTING ELEVATED STORAGE TANK  
MIXER ELEVATION**  
SCALE: 1" = 30'

**KEYED NOTES**

- ① DEDICATED 20A WR RECEPTACLE WITH IN USE COVER FOR SUMP PUMP.
- ② ALL IXOM EQUIPMENT TO BE PROVIDED WITH LOCAL DISCONNECT MOUNTED TO OR NEAR EQUIPMENT ON TOP OF THE TANK. DISCONNECT SWITCH RATINGS CALLED OUT ON 8E2.
- ③ PROVIDE GFEP BREAKER (IN LP-TNK TO PROVIDE POWER TO CP-TNK), JUNCTION BOXES, CONDUIT, AND WIRE AS REQUIRED BY THE MANUFACTURER.

**GENERAL NOTES:**

- 1. INSTALL SUBMERSIBLE GRIDBEE GS-9 MIXING SYSTEM OR APPROVED EQUAL PER SECTION 11330. MIXER INSTALLATION SHALL BE ON THE BOTTOM OF THE TANK WITH A MINIMUM 24" WATER DEPTH.

For Viewing Purposes Only - Visit [www.wesslerengineering.com](http://www.wesslerengineering.com) to Purchase

Drawing: X:\Hogdale\_C01703222\_Hogdale WTP\Contract B - Booster Station and WTP\DWG\Sheets\703222-EL-EX-GST.dwg | Layout: 5E1 | Plotter: CP/05/26 @ 09:27:38 | LastSavedBy: jshk

SCALE VERIFICATION	DRAWN BY	JLK	NO.	DATE	INITIALS	REVISION DESCRIPTIONS
BAR IS ONE INCH LONG ON ORIGINAL DRAWING 	CHECKED BY	JAP				
	APPROVED BY	WCM				
	ISSUE DATE	FEBRUARY 2026				
	PROJECT NUMBER	703222-04-001				

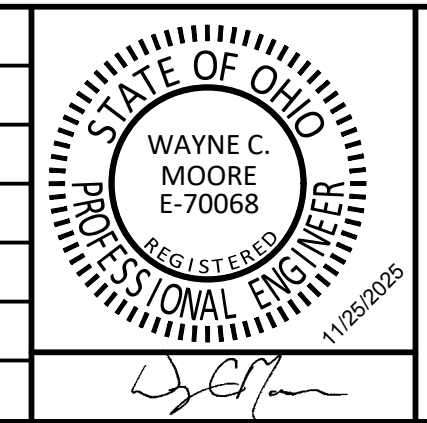

<b>WATER SYSTEM IMPROVEMENTS</b> CONTRACT B NEW BOOSTER STATION AND WATER TREATMENT PLANT IMPROVEMENTS VILLAGE OF HOGGATE, OHIO
<b>EXISTING STORAGE TANKS ELECTRICAL IMPROVEMENTS</b>

SHEET NO. <b>5E1</b>
PAGE NO. <b>29</b>
DDAGW-4113 02/23/2026

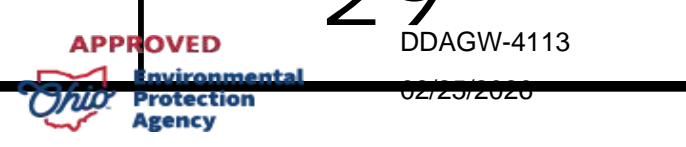

For Viewing Purposes Only - Visit [www.wesslerengineering.com](http://www.wesslerengineering.com) to Purchase

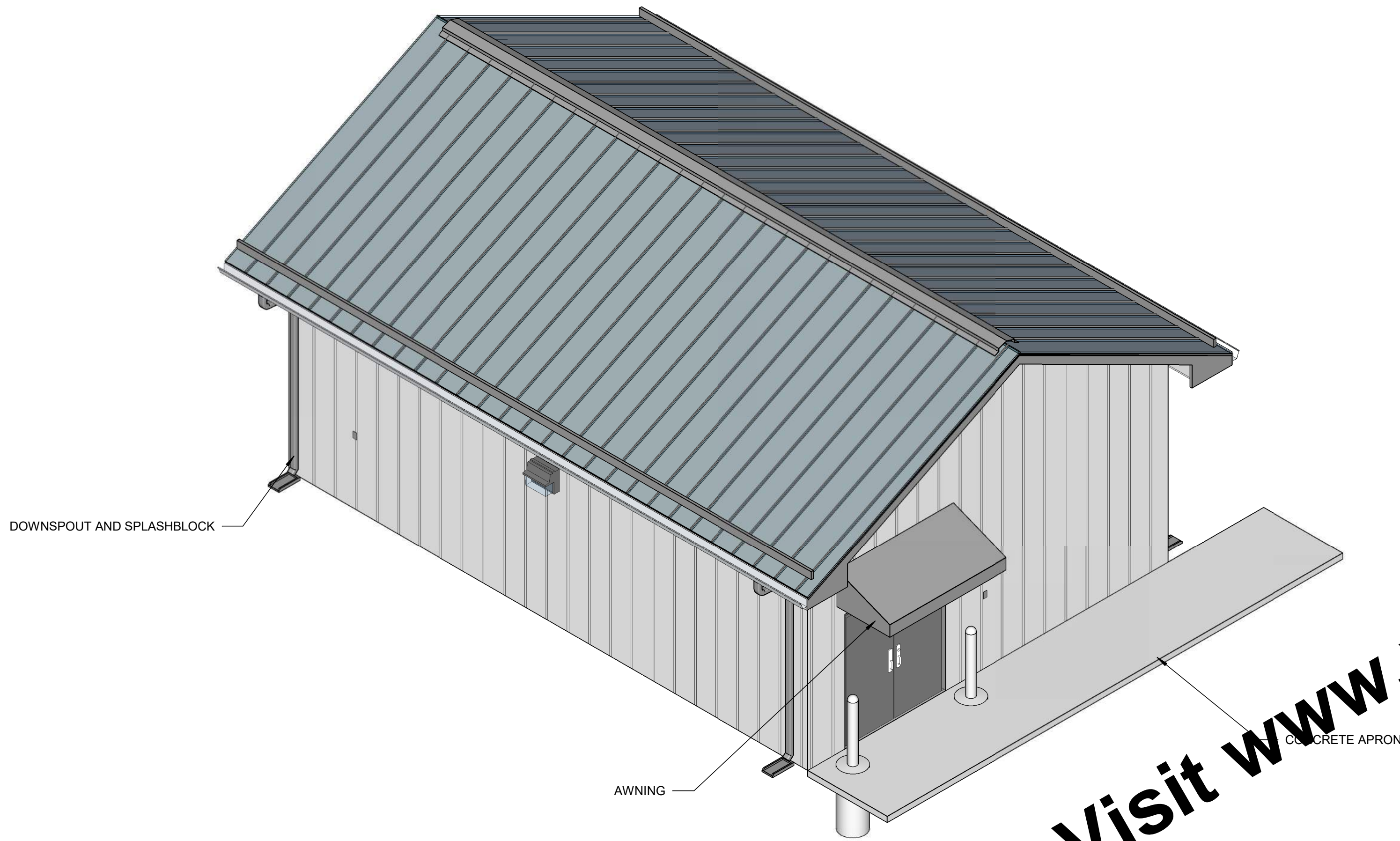

PERSPECTIVE VIEW - NORTHEAST  
SCALE: NONE

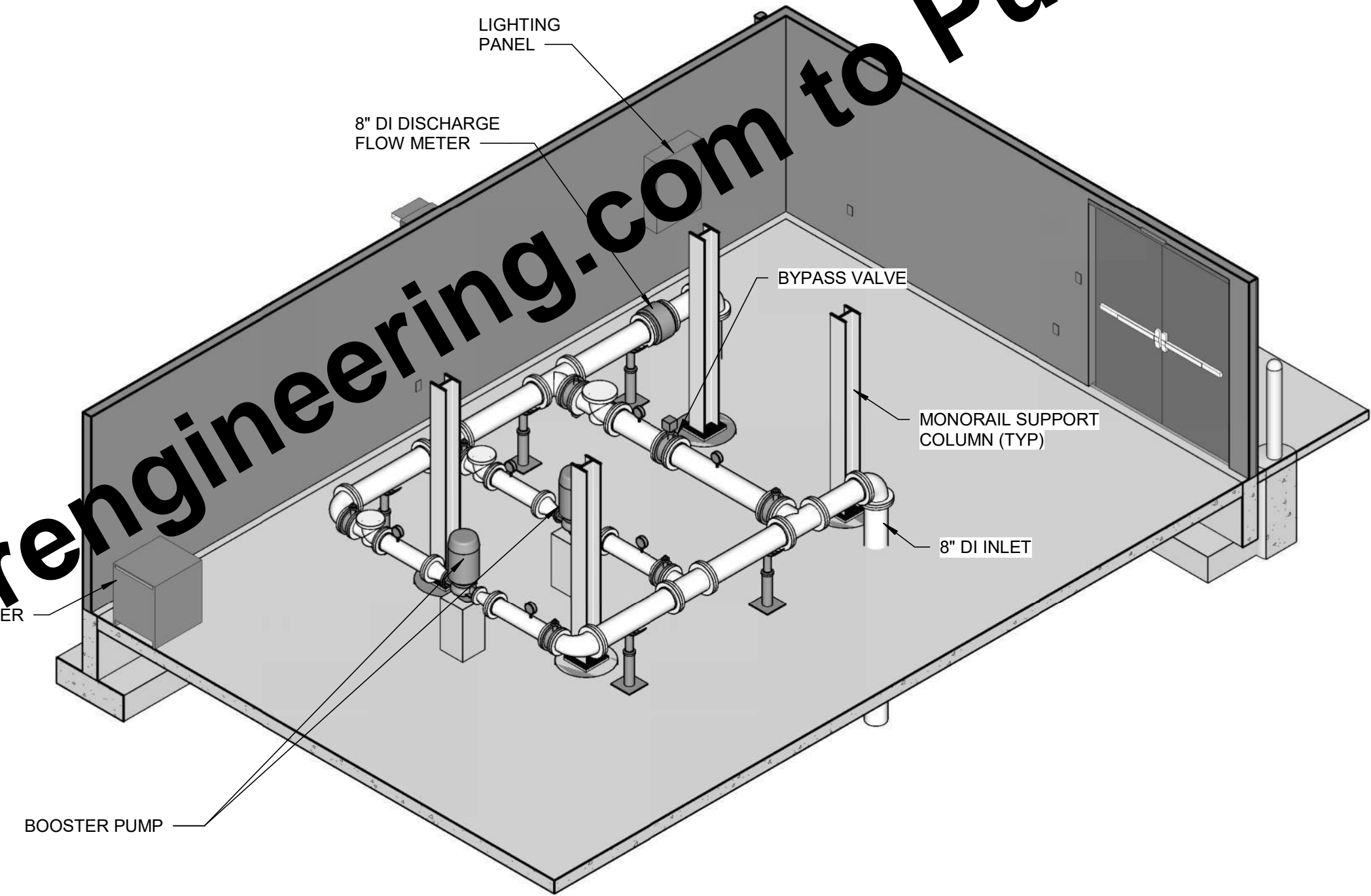

CUTAWAY VIEW - SOUTHWEST  
SCALE: NONE

NOTE: PERSPECTIVE VIEWS ARE FOR ILLUSTRATIONS ONLY.

Plotted: 1/22/2026 8:50:59 AM C:\Autodesk\Revit Local\703222-BS-NEW-AGENT-25\_CurtisGramann.rvt

SCALE VERIFICATION	DRAWN BY	CLG	NO.	DATE	INITIALS	REVISION DESCRIPTION
BAR IS ONE INCH LONG ON ORIGINAL DRAWING 	CHECKED BY	MAP				
	APPROVED BY	AMS				
	ISSUE DATE	FEBRUARY 2026				
	PROJECT NUMBER	703222-04-001				

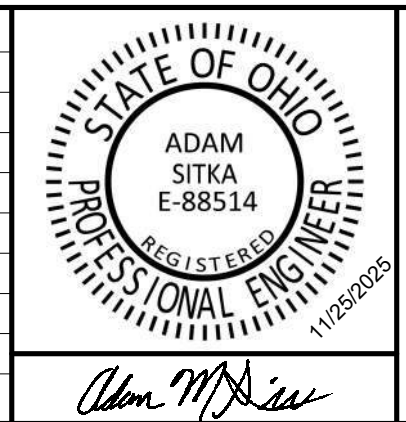

**WATER SYSTEM IMPROVEMENTS**  
 CONTRACT B NEW BOOSTER STATION AND TREATMENT PLANT IMPROVEMENTS  
 VILLAGE OF HOLTGATE OHIO

**NEW BOOSTER STATION**  
**PERSPECTIVE VIEWS**

SHEET NO.	6G1
PAGE NUMBER	30
DDAGW-4113	02/25/2026



Plotted: 1/22/2026 8:54:25 AM C:\Autodesk\Revit Local\703222-BS-NEW-GEN-25\_CurtisGramann.rvt

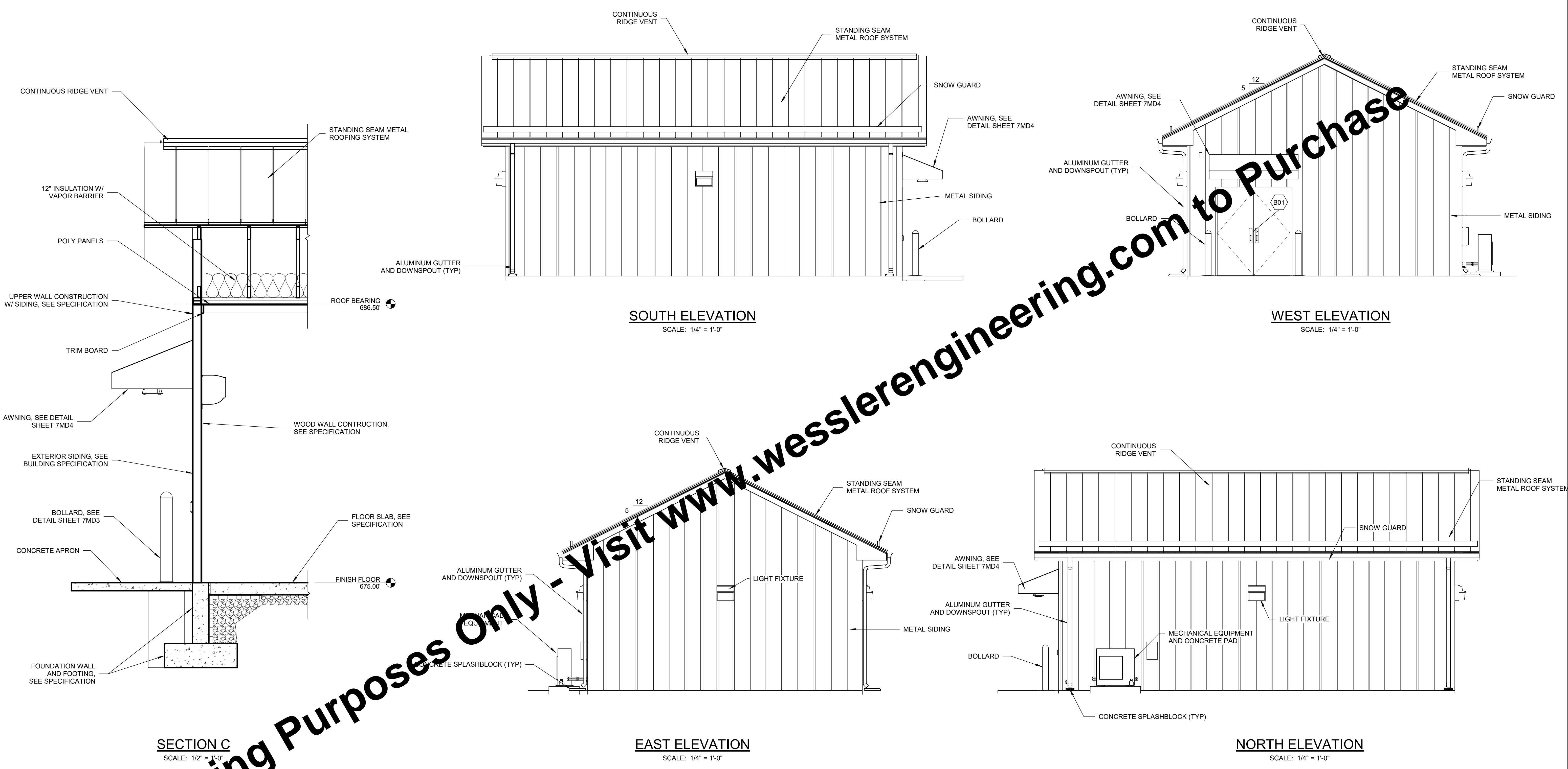

For Viewing Purposes Only - Visit [www.wesslerengineering.com](http://www.wesslerengineering.com) to Purchase

**SECTION C**  
SCALE: 1/2" = 1'-0"

**SOUTH ELEVATION**  
SCALE: 1/4" = 1'-0"

**WEST ELEVATION**  
SCALE: 1/4" = 1'-0"

**EAST ELEVATION**  
SCALE: 1/4" = 1'-0"

**NORTH ELEVATION**  
SCALE: 1/4" = 1'-0"

SCALE VERIFICATION	DRAWN BY	CLG	NO.	DATE	INITIALS	REVISION DESCRIPTION
BAR IS ONE INCH LONG ON ORIGINAL DRAWING  	CHECKED BY	MAP				
	APPROVED BY	AMS				
	ISSUE DATE	FEBRUARY 2026				
	PROJECT NUMBER	703222-04-001				

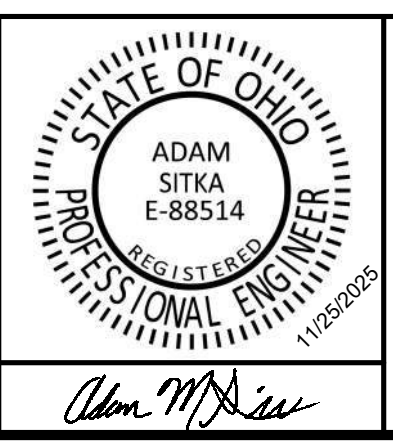

**WATER SYSTEM IMPROVEMENTS**  
 CONTRACT B NEW BOOSTER STATION AND TREATMENT PLANT IMPROVEMENTS  
 VILLAGE OF HOLGATE OHIO  
**NEW BOOSTER STATION BUILDING ELEVATIONS**

SHEET NO.	6A1
PAGE NUMBER	31
DDAGW-4113	02/25/2026



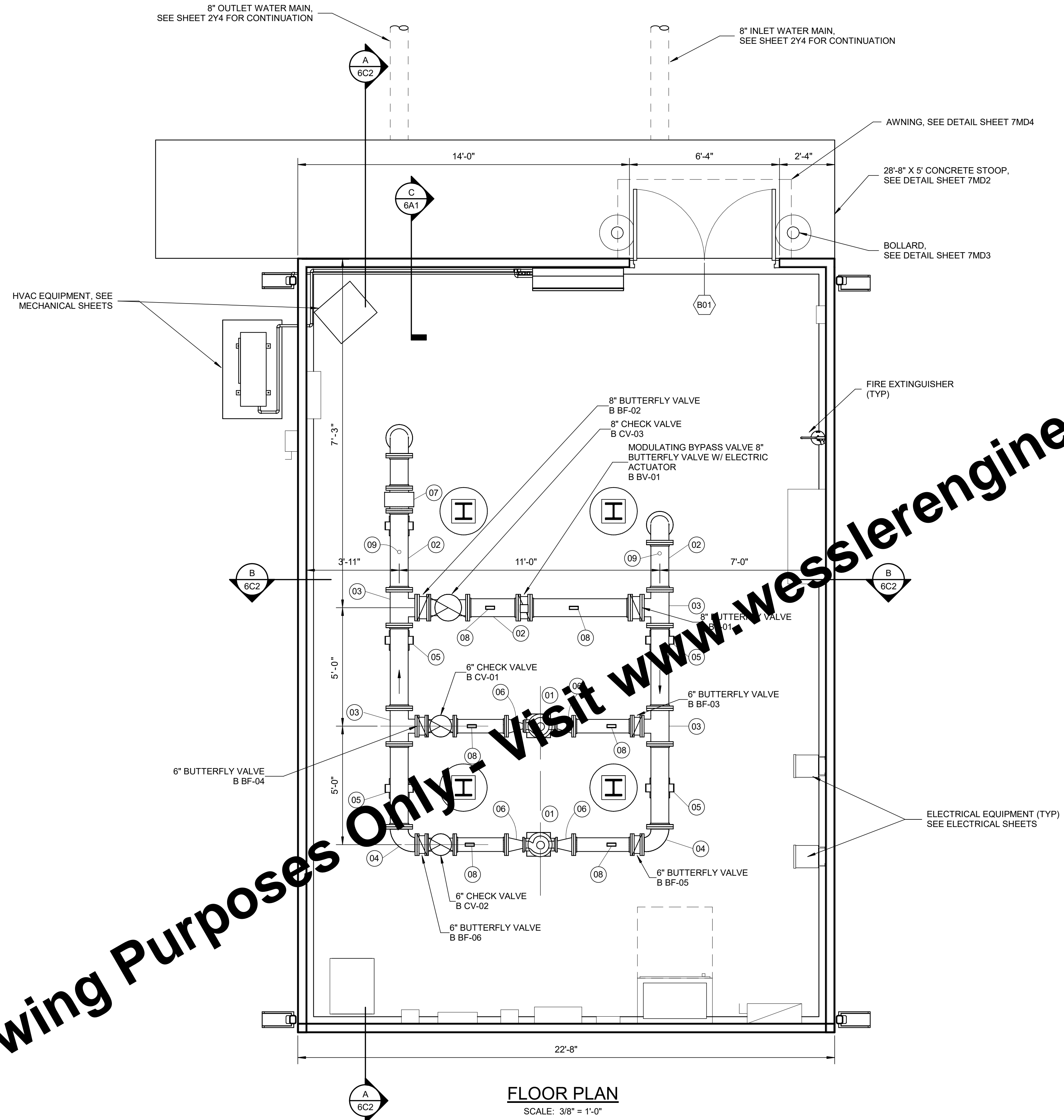
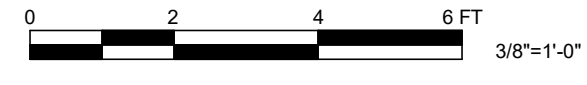
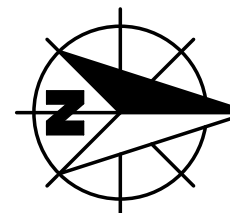

FLOOR PLAN  
SCALE: 3/8" = 1'-0"

**KEYED NOTES:** #

- 01 NEW BOOSTER PUMPS W/ BASE AND 12" SQUARE CONCRETE BASES (TYP OF 2)
- 02 8" DUCTILE IRON PIPE
- 03 8" X 6" DUCTILE IRON TEE
- 04 8" X 6" DUCTILE IRON 90 DEGREE REDUCING BEND
- 05 PIPE SUPPORTS, INSTALLED AS SPECIFIED BY MANUFACTURER, SEE SPECIFICATIONS
- 06 6" X 2" DUCTILE IRON ECCENTRIC REDUCER
- 07 8" FLOW METER PROVIDED BY OTHERS AND INSTALLED BY CONTRACTOR. CONTRACTOR TO PROVIDE AN EQUAL LENGTH 8" DUCTILE IRON SPOOL PIECE TO REPLACE METER DURING MAINTENANCE
- 08 PRESSURE TRANSMITTER AND PRESSURE GAUGE
- 09 SMOOTH NOSE SAMPLE TAP

For Viewing Purposes Only, visit [www.wesslerengineering.com](http://www.wesslerengineering.com) to Purchase

Plotted: 1/22/2026 8:55:19 AM C:\Autodesk\Revit Local\703222-BN-NEW-GEN-25\_CurtisGramann.rvt

SCALE VERIFICATION	DRAWN BY CLG	NO.	DATE	INITIALS	REVISION DESCRIPTION
BAR IS ONE INCH LONG ON ORIGINAL DRAWING 	CHECKED BY MAP				
	APPROVED BY AMS				
	ISSUE DATE FEBRUARY 2026				
	PROJECT NUMBER 703222-04-001				

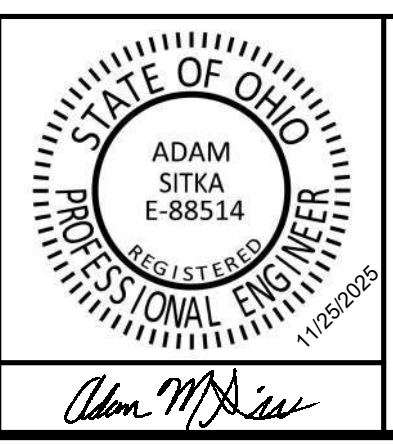

**WATER SYSTEM IMPROVEMENTS**  
CONTRACT B NEW BOOSTER STATION AND TREATMENT PLANT IMPROVEMENTS  
VILLAGE OF HOLGATE OHIO

**NEW BOOSTER STATION  
FLOOR PLAN**

SHEET NO. <b>6C1</b>
PAGE NUMBER <b>32</b>
DDAGW-4113 02/25/2026



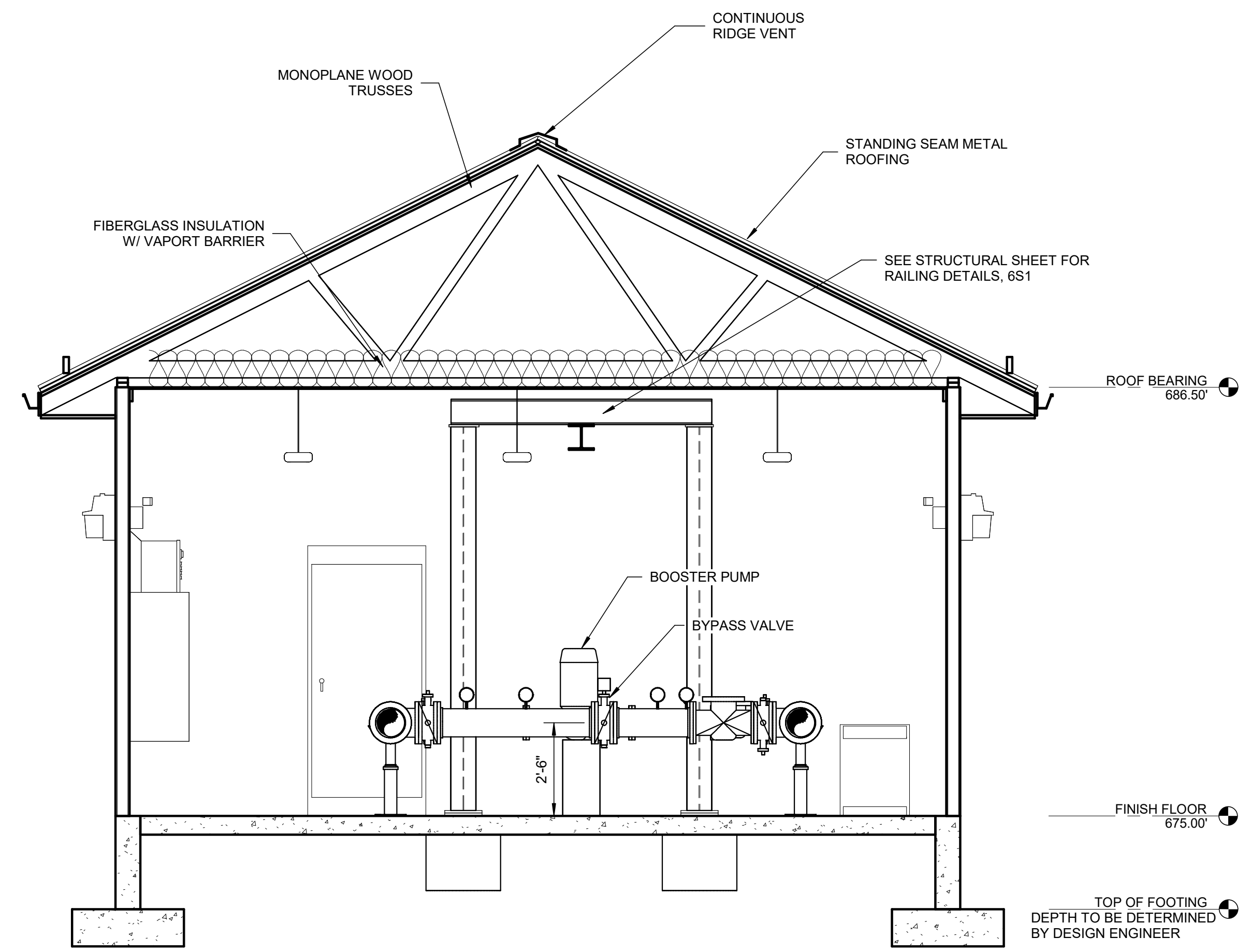

SECTION B  
SCALE: 3/8" = 1'-0"  
6C1

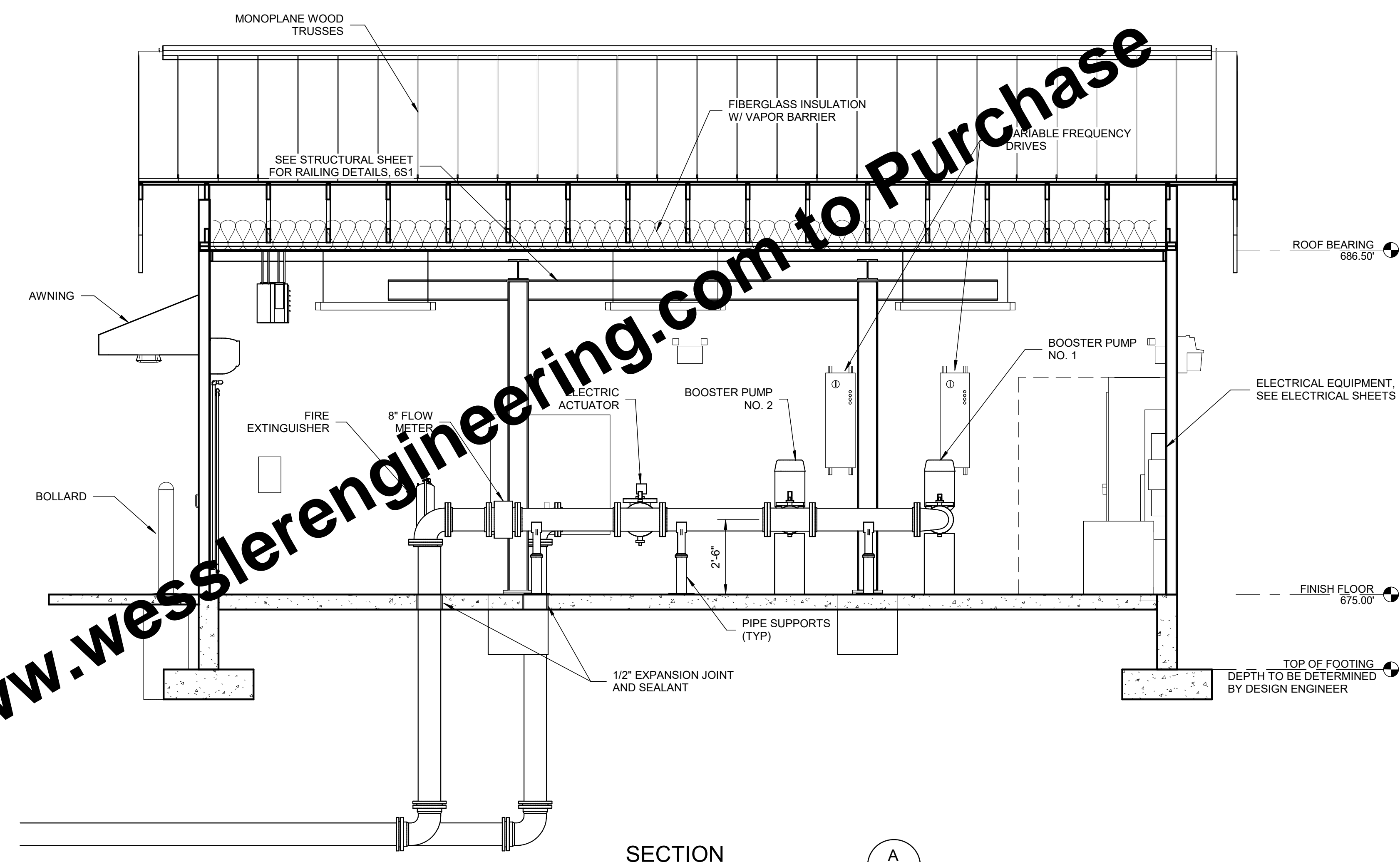

SECTION A  
SCALE: 3/8" = 1'-0"  
6C1

For Viewing Purposes Only - Visit [www.wesslerengineering.com](http://www.wesslerengineering.com) to Purchase

Plotted: 1/22/2026 9:03:27 AM C:\Autodesk\Revit Local\703222-B5-NEW-AGENT-25\_CurtisGramann.rvt

SCALE VERIFICATION	DRAWN BY	CLG	NO.	DATE	INITIALS	REVISION DESCRIPTION
BAR IS ONE INCH LONG ON ORIGINAL DRAWING  	CHECKED BY	MAP				
	APPROVED BY	AMS				
	ISSUE DATE	FEBRUARY 2026				
	PROJECT NUMBER	703222-04-001				

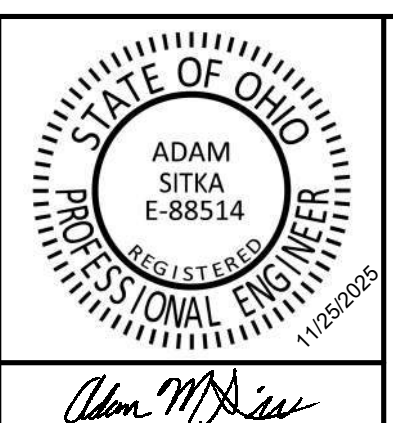

**WATER SYSTEM IMPROVEMENTS**  
 CONTRACT B NEW BOOSTER STATION AND TREATMENT PLANT IMPROVEMENTS  
 VILLAGE OF HOLTGATE OHIO

**NEW BOOSTER STATION  
 BUILDING SECTIONS**

SHEET NO. <b>6C2</b>
PAGE NUMBER <b>33</b>
DDAGW-4113 02/25/2026



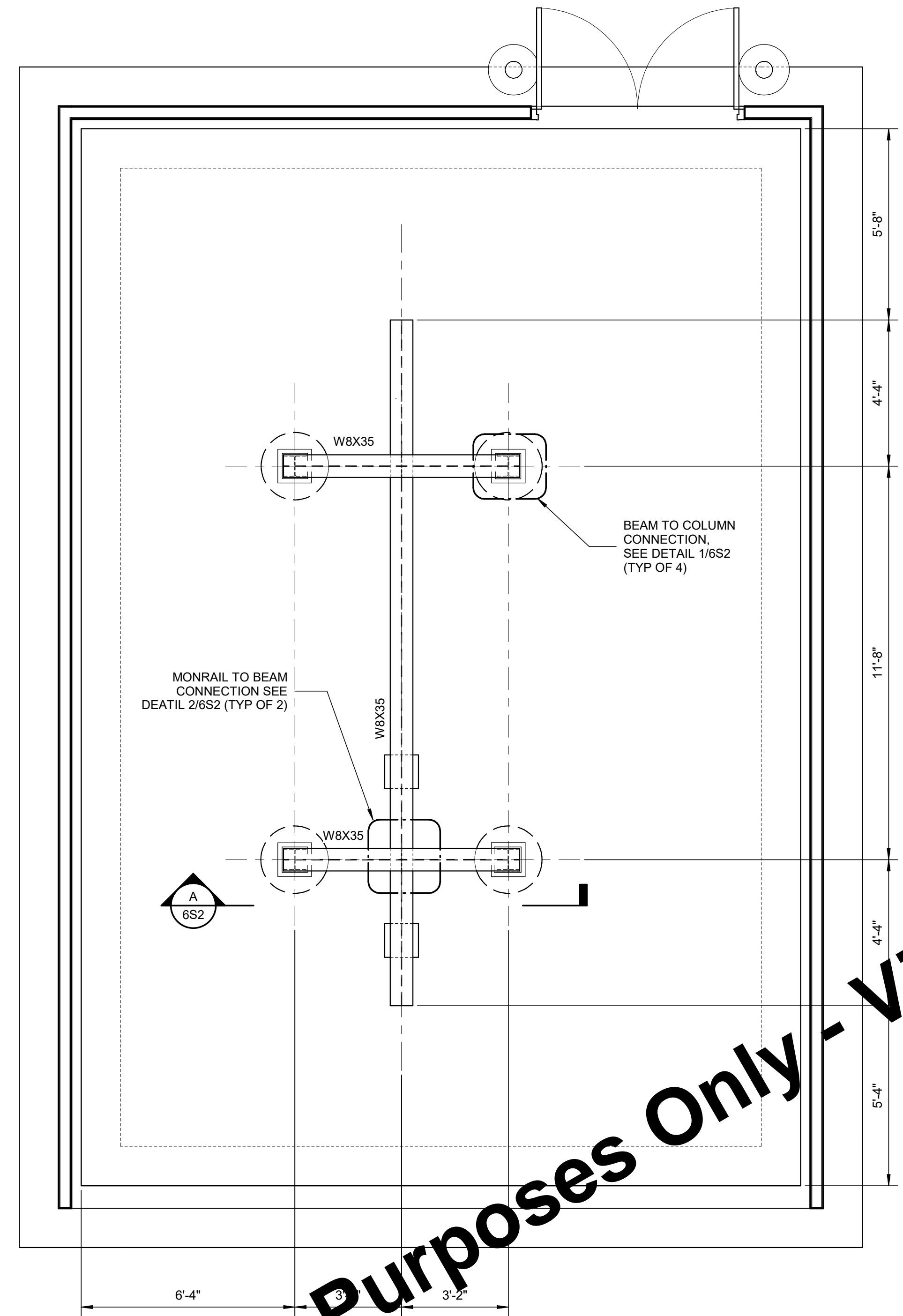
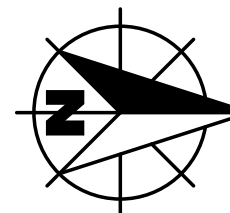

**MONORAIL FRAMING PLAN**  
SCALE: 3/8" = 1'-0"

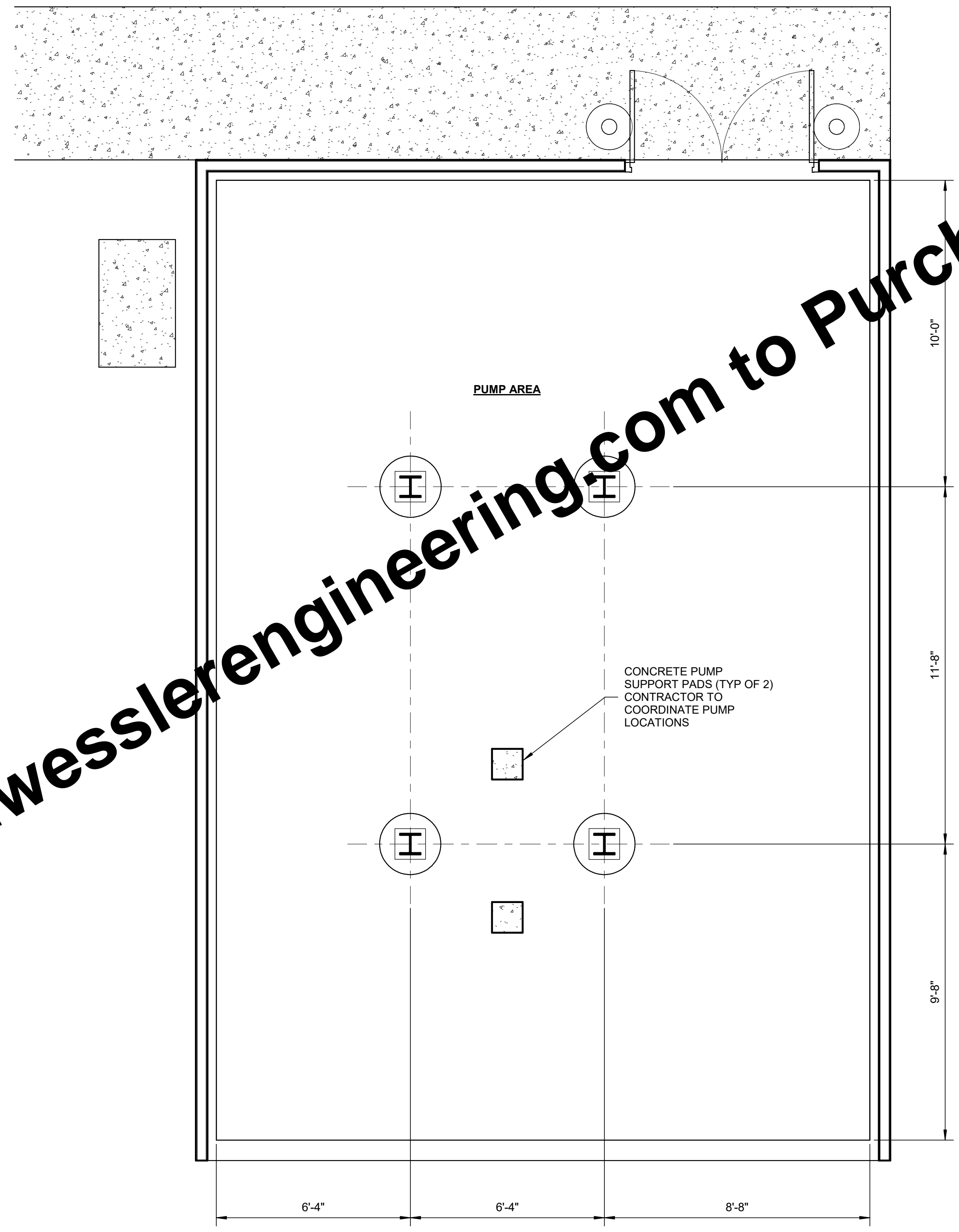

**MONORAIL FOUNDATION PLAN**  
SCALE: 3/8" = 1'-0"

**MONORAIL PLAN NOTES:**

1. BUILDING, SLAB-ON-GRADE, AND FOUNDATION DESIGNED BY OTHERS.
2. ALL STRUCTURAL MEMBERS ARE W8X35.
3. MONORAIL FRAME TO BE LOCATED SUCH THAT MONORAIL BEAM IS ALIGNED W/ CENTERLINE OF PUMPS.

For Viewing Purposes Only - Visit [www.wesslerengineering.com](http://www.wesslerengineering.com) to Purchase

Plotted: 1/22/2026 9:08:35 AM C:\Autodesk\Revit Local\703222-BS-NEW-GEN-25\_CurtisGramman.rvt

SCALE VERIFICATION  BAR IS ONE INCH LONG ON ORIGINAL DRAWING 	DRAWN BY	CLG	NO.	DATE	INITIALS	REVISION DESCRIPTION
	CHECKED BY	JW				
	APPROVED BY	JCB				
	ISSUE DATE					
	FEBRUARY 2026					
PROJECT NUMBER						
703222-04-001						

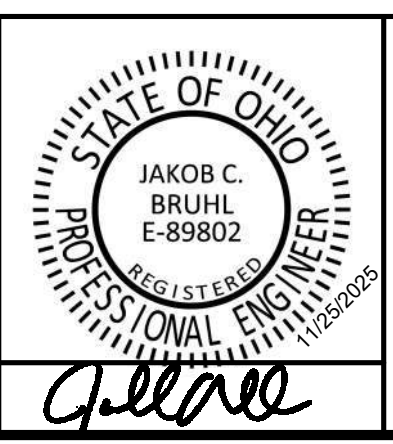

**WATER SYSTEM IMPROVEMENTS**  
CONTRACT B NEW BOOSTER STATION AND TREATMENT PLANT IMPROVEMENTS  
VILLAGE OF HOLTGATE OHIO

**NEW BOOSTER STATION**  
**MONORAIL FRAME STRUCTURAL PLAN**

SHEET NO.  
**6S1**

PAGE NUMBER  
**34**

DDAGW-4113  
02/25/2026



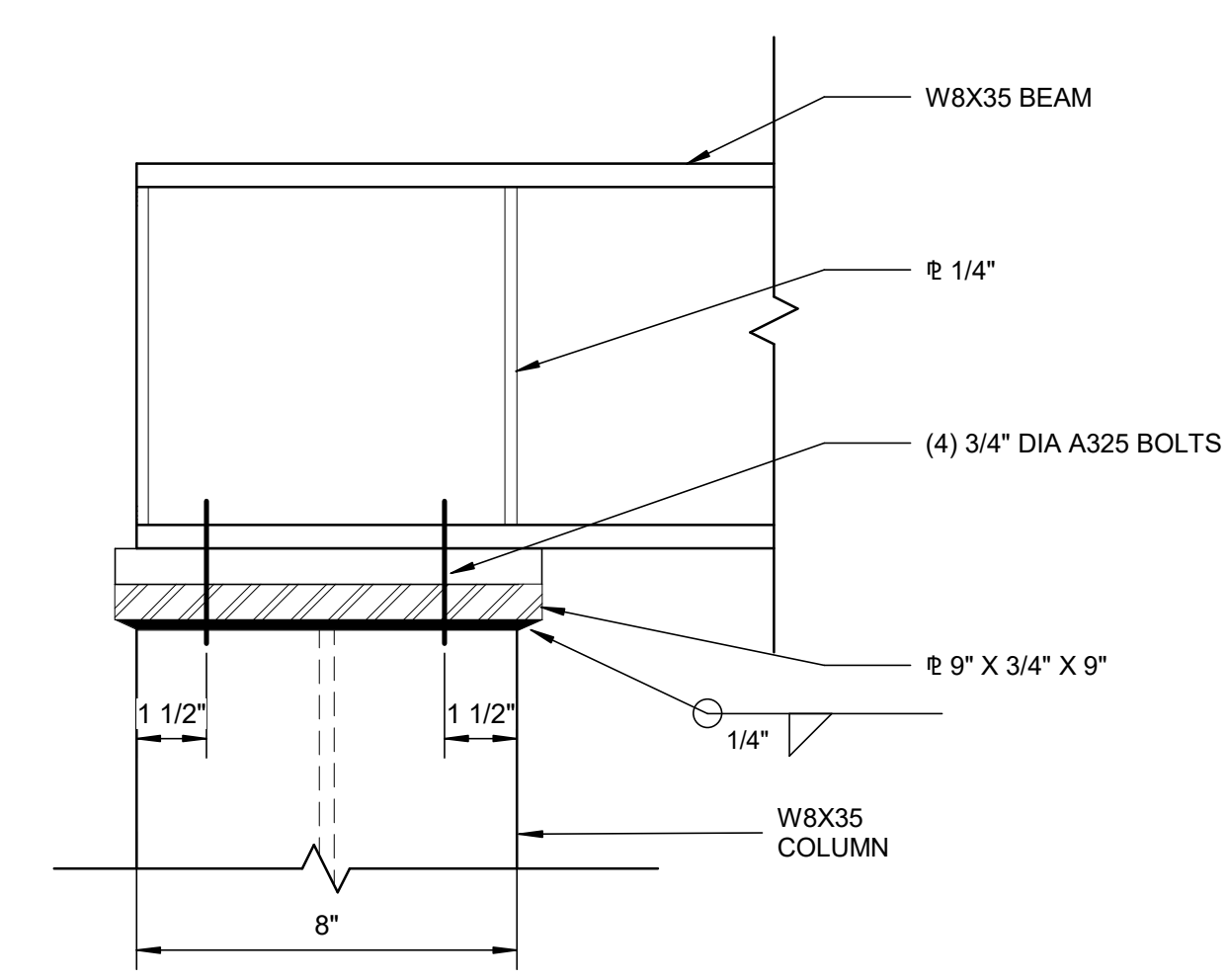

SECTION A-A

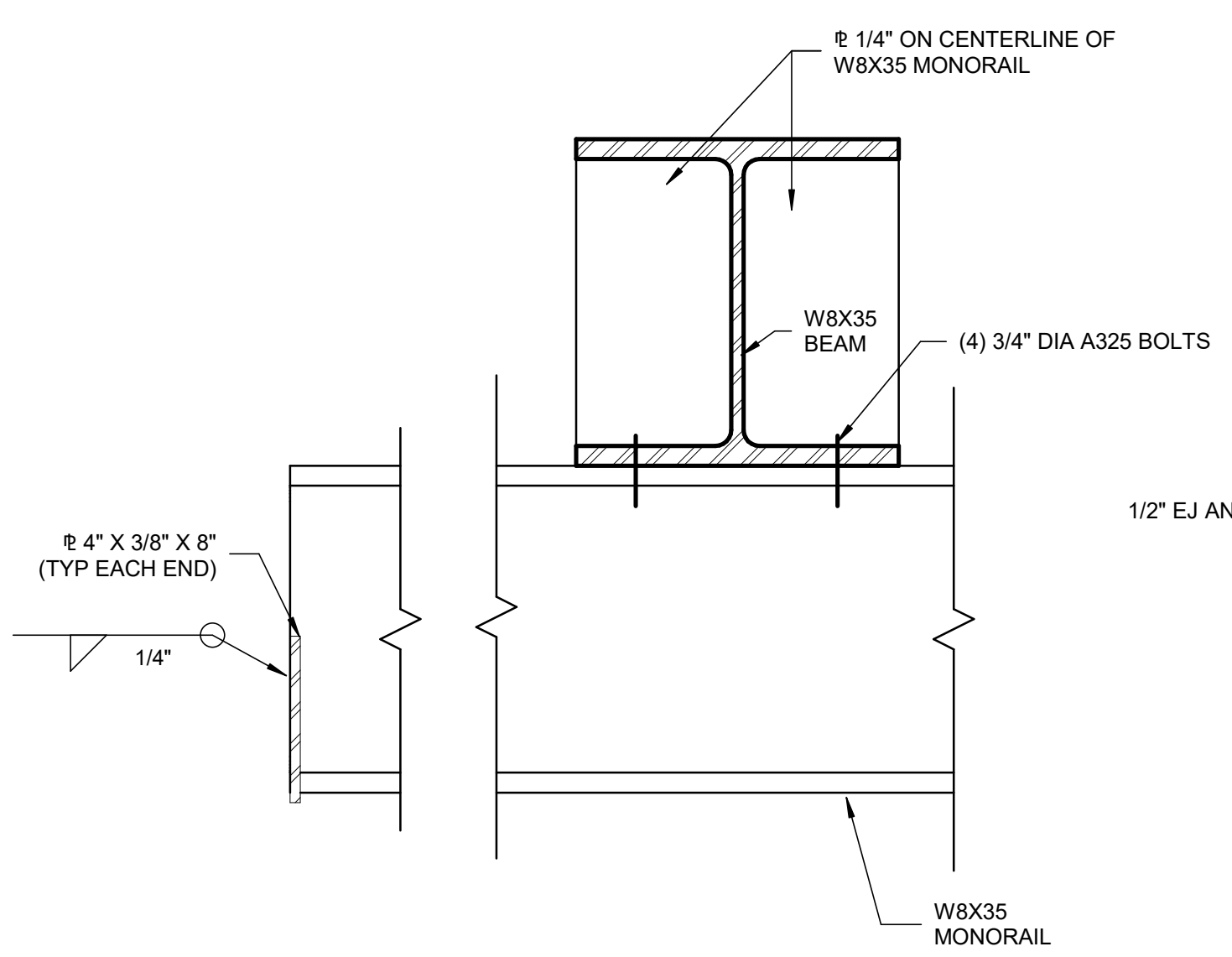

SECTION B-B

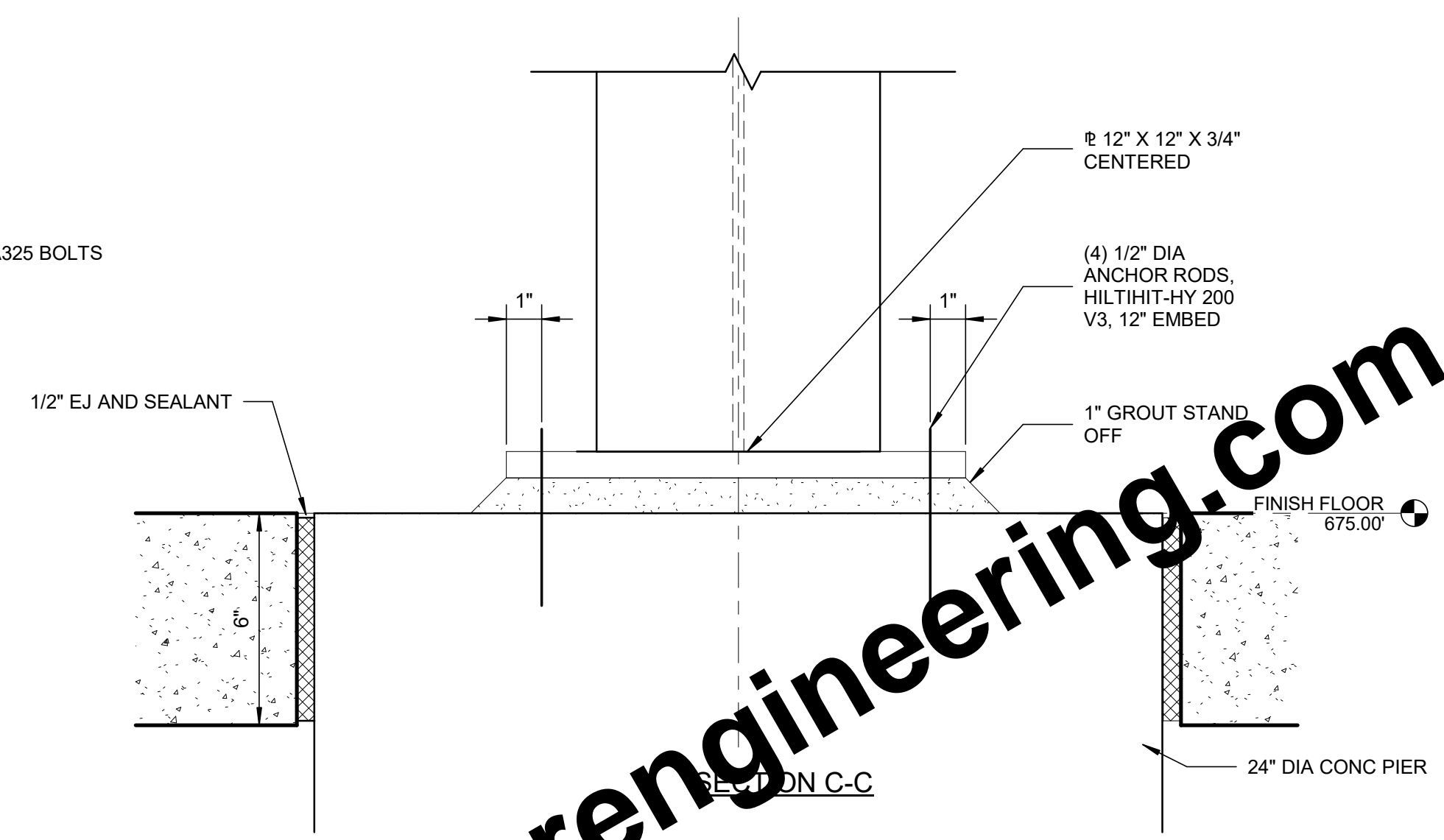

SECTION C-C

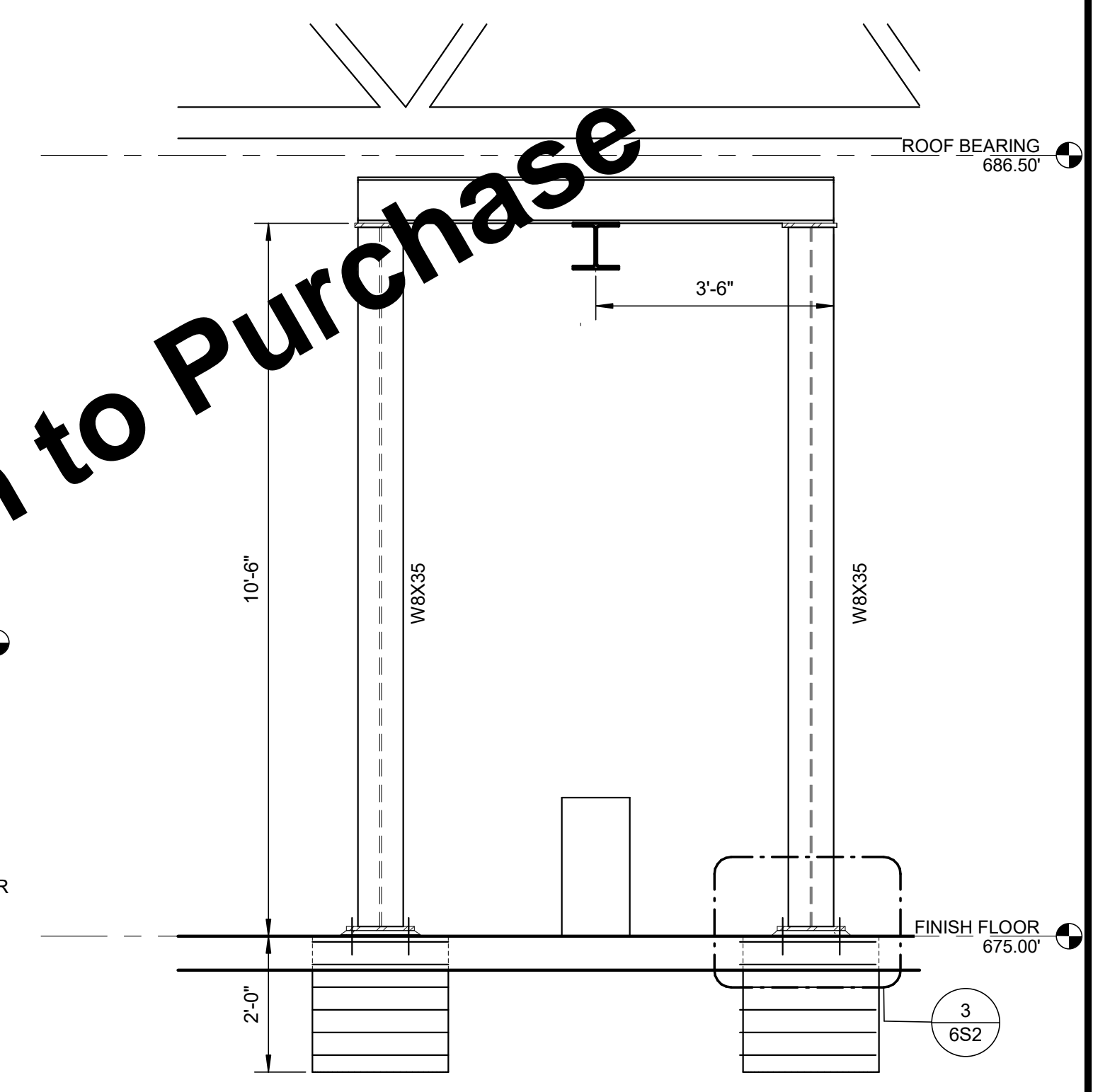

SECTION A

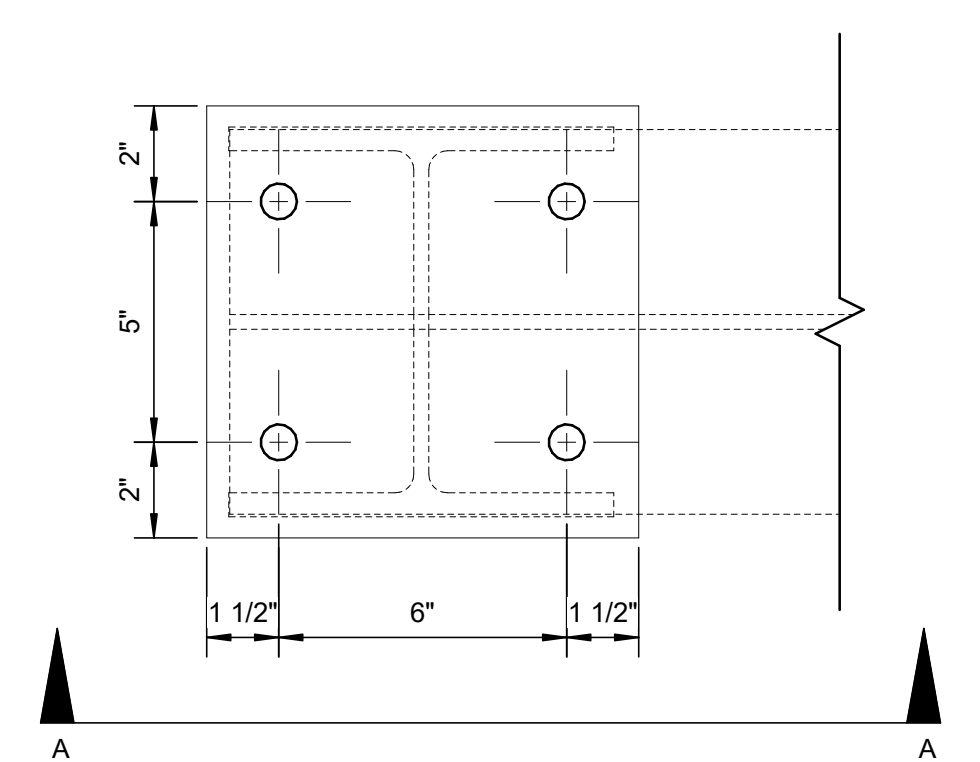

PLAN

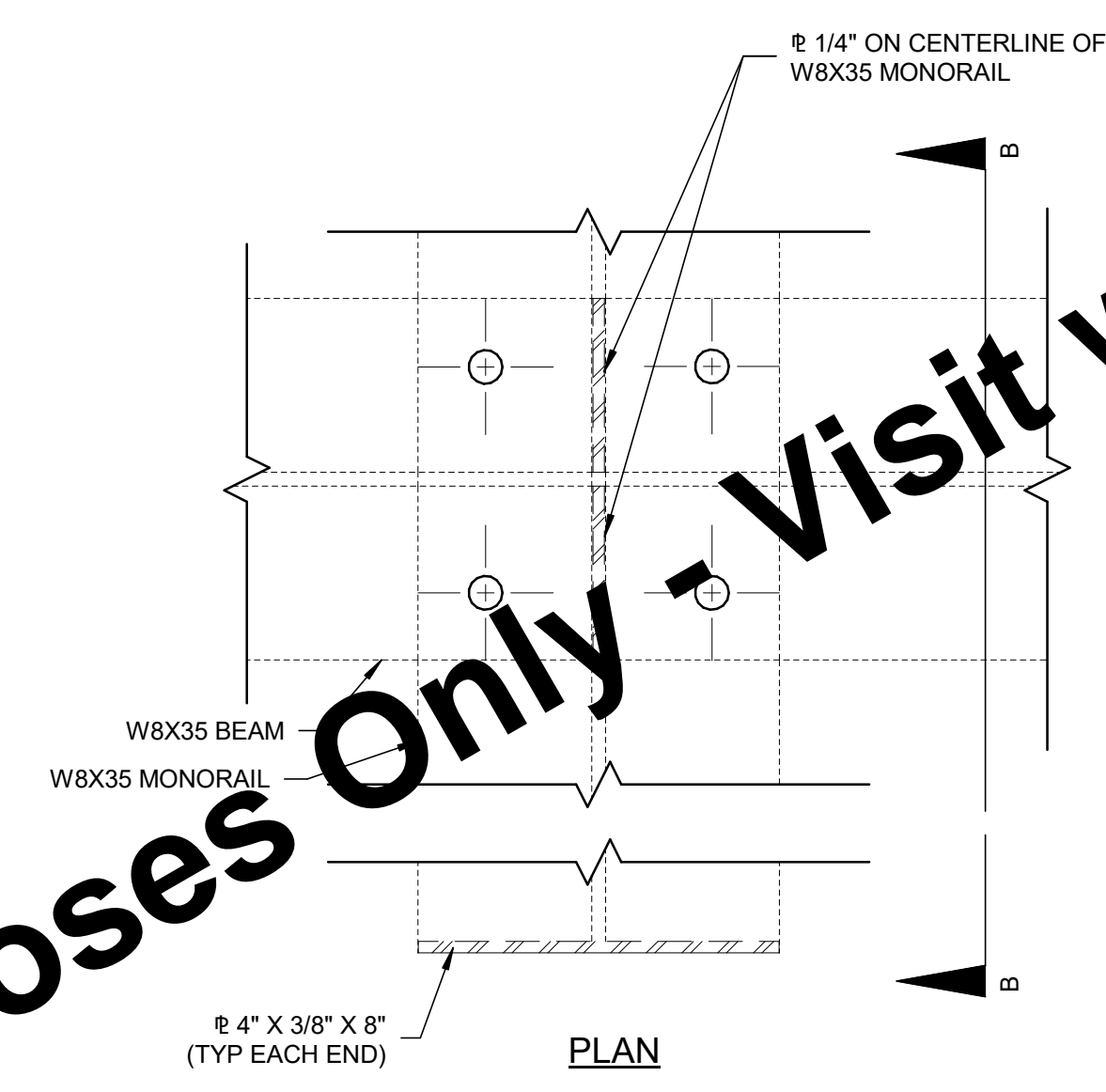

PLAN

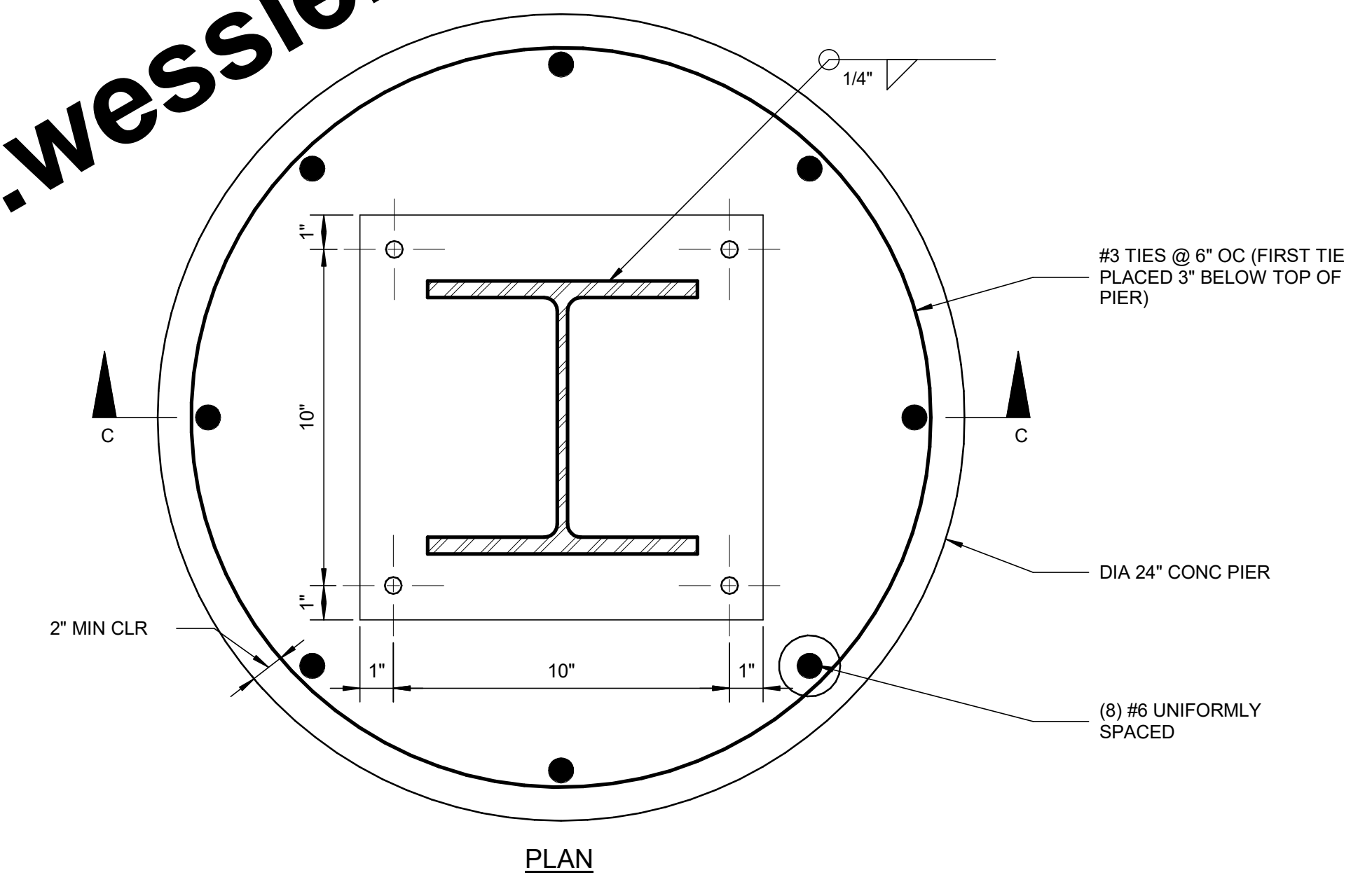

PLAN

BEAM TO COLUMN CONNECTION DETAIL  
SCALE: 3" = 1'-0"

BEAM TO MONORAIL CONNECTION DETAIL  
SCALE: 3" = 1'-0"

BASE PLATE AND FOOTING DETAIL  
SCALE: 3" = 1'-0"

SECTION A  
SCALE: 1/2" = 1'-0"  
NOTE: LABEL MONORAIL 1/2 TON BOTH SIDES

For Viewing Purposes Only - Visit [www.wesslerengineering.com](http://www.wesslerengineering.com) to Purchase

Plotted: 1/22/2026 9:09:40 AM C:\Autodesk\Revit Local\703222-BS-NEW-GENT-25-CurtisGramann.rvt

SCALE VERIFICATION	DRAWN BY	CLG	NO.	DATE	INITIALS	REVISION DESCRIPTION
BAR IS ONE INCH LONG ON ORIGINAL DRAWING 	CHECKED BY	JW				
	APPROVED BY	JCB				
	ISSUE DATE	FEBRUARY 2026				
	PROJECT NUMBER	703222-04-001				

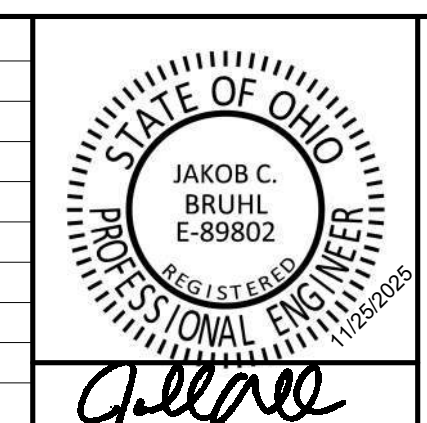

**WATER SYSTEM IMPROVEMENTS**  
 CONTRACT B NEW BOOSTER STATION AND TREATMENT PLANT IMPROVEMENTS  
 VILLAGE OF HOLTGATE OHIO

**NEW BOOSTER STATION**  
**MONORAIL FRAME, SECTION AND DETAILS**

SHEET NO.  
**6S2**

PAGE NUMBER  
**35**

DDAGW-4113  
02/25/2026



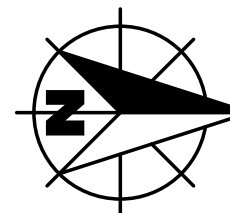

**GENERAL NOTES:**

1. REFER TO SHEET 1M1 MECHANICAL SYMBOLS AND NOTATION FOR ADDITIONAL REQUIREMENTS.
2. INSULATE DUCTWORK BETWEEN EXTERIOR WALL/ROOF AND MOTORIZED INSULATION DAMPERS.
3. HVAC REFRIGERANT ASSUMES WALLS DO NOT GO TO DECK. IF PERFORMING BUILDING WALLS GO TO DECK, THEN PROVIDE WALL OPENINGS ABOVE CEILING WITH ENGINEER.

**KEYED NOTES:** ○

1. MOUNT OUTDOOR UNIT ON 8" HOUSEKEEPING PAD, TOP AT 4" ABOVE GRADE, MINIMUM 6" WIDER THAN UNIT IN EACH DIRECTION.
2. MOUNT BOTTOM OF UNIT AT 7'-0" A.F.F.
3. 3/4" CONDENSATE, TERMINATE WITH ELBOW DOWN 12" OFF GRADE. PROVIDE TRAP AT UNIT AND SLOPE TO TERMINATION.
4. MOUNT BOTTOM OF HEATER AT 7'-6" A.F.F.

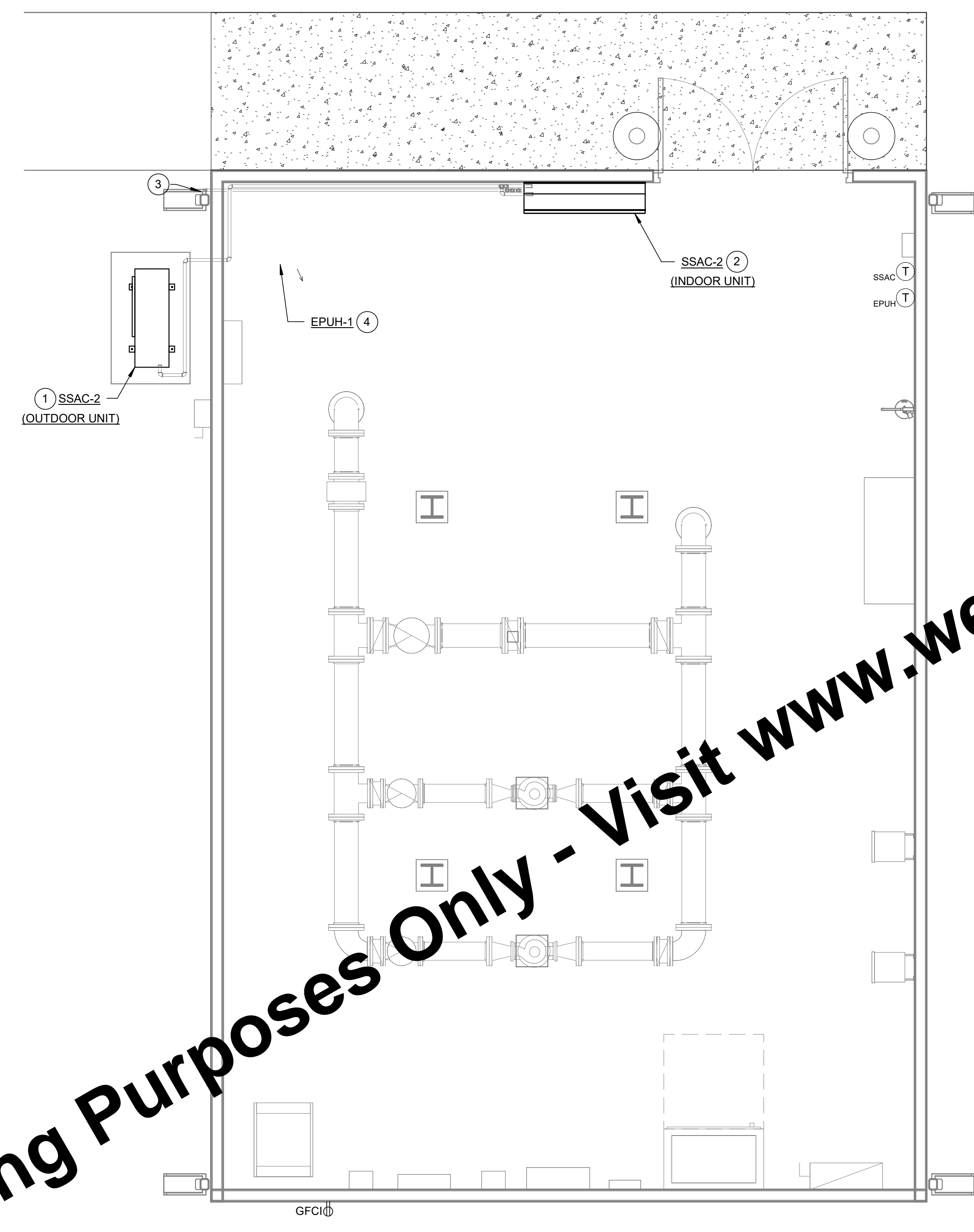

**HVAC PLAN**  
SCALE: 3/8" = 1'-0"

For Viewing Purposes Only - Visit [www.wesslerengineering.com](http://www.wesslerengineering.com) to Purchase

Plotted: 1/22/2026 9:10:47 AM C:\Autodesk\Revit Local\703222\BS-NEW-GEN-25\_CurtisGramann.rvt

SCALE VERIFICATION	DRAWN BY	CLG	NO.	DATE	INITIALS	REVISION DESCRIPTION
BAR IS ONE INCH LONG ON ORIGINAL DRAWING  	CHECKED BY	SPR				
	APPROVED BY	WCM				
	ISSUE DATE	FEBRUARY 2026				
	PROJECT NUMBER	703222-04-001				

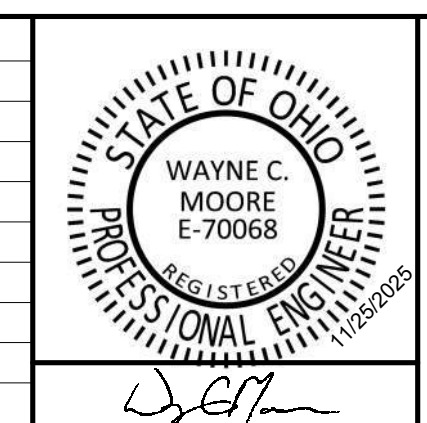

**WATER SYSTEM IMPROVEMENTS**  
CONTRACT B NEW BOOSTER STATION AND TREATMENT PLANT IMPROVEMENTS  
VILLAGE OF HOLTGATE OHIO

**NEW BOOSTER STATION  
HVAC PLAN**

SHEET NO.	6M1
PAGE NUMBER	36
DDAGW-4113	02/25/2026



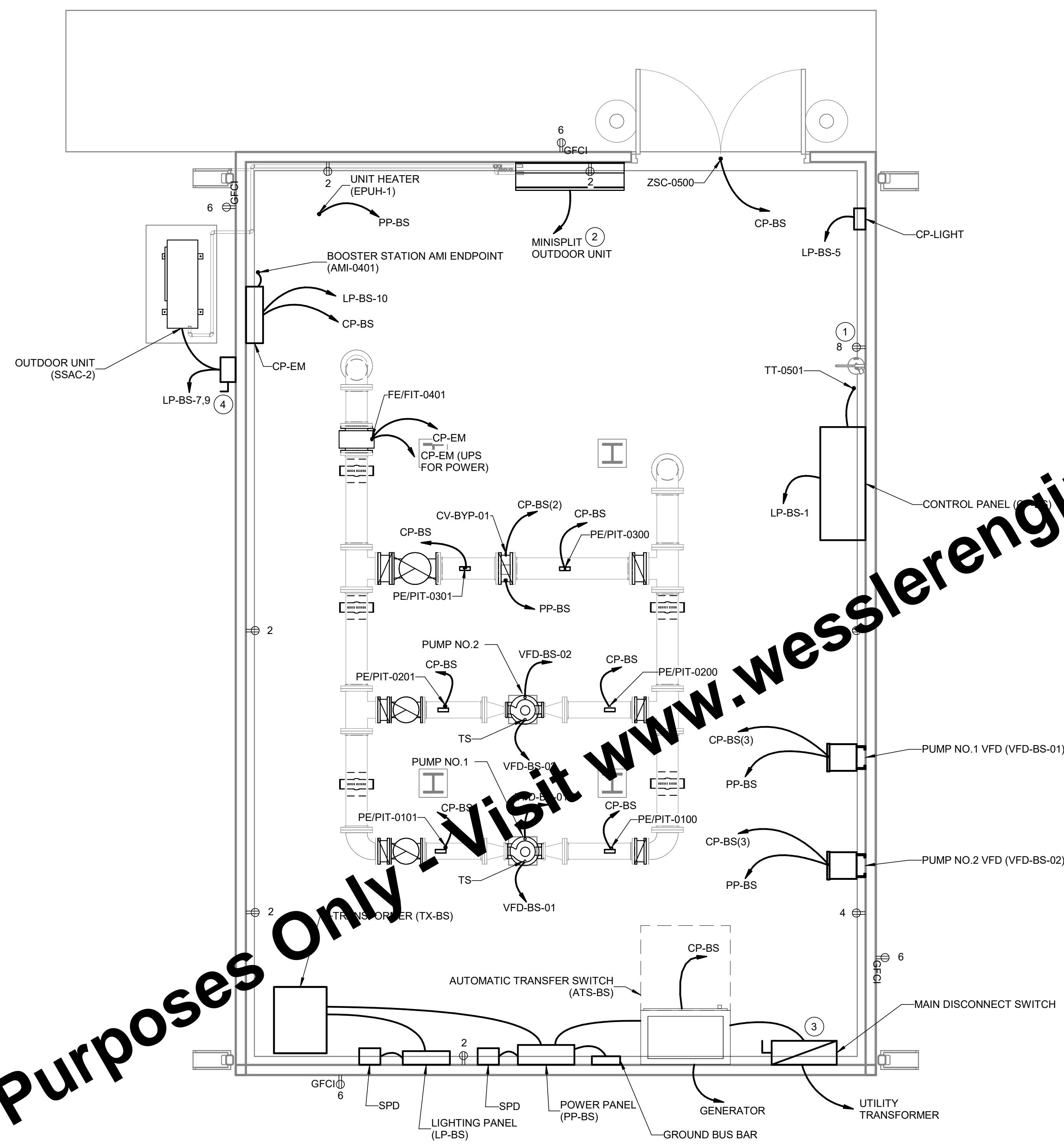
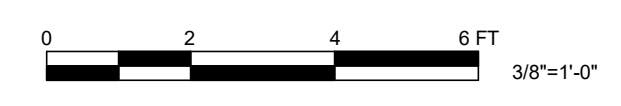
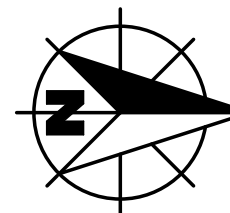

**POWER PLAN**  
SCALE: 3/8" = 1'-0"

- KEYED NOTES:** #
1. RECEPTACLE TO BE ON ITS OWN DEDICATED CIRCUIT FOR FUTURE EQUIPMENT. PROVIDE NECESSARY WIRING AND CONDUIT TO CONNECT ALL HVAC EQUIPMENT (SUCH AS MINISPLIT INDOOR UNITS AND THERMOSTATS) AS RECOMMENDED BY THE MANUFACTURER. UTILIZE 3/4" MINIMUM.
  2. 480V, 3P, 400A FUSIBLE, SER, NEMA 12 DISCONNECT SWITCH.
  3. 208V, 2P, 60A, NON-FUSIBLE, NEMA 4X S.S. DISCONNECT SWITCH.

For Viewing Purposes Only - Visit [www.wesslerengineering.com](http://www.wesslerengineering.com) to Purchase

Plotted: 1/22/2026 9:11:37 AM C:\Autodesk\Revit Local\703222-BS-NEW-GEN-25\_CurtisGramann.rvt

SCALE VERIFICATION	DRAWN BY	JLK	NO.	DATE	INITIALS	REVISION DESCRIPTION
BAR IS ONE INCH LONG ON ORIGINAL DRAWING 	CHECKED BY	JAP				
	APPROVED BY	WCM				
	ISSUE DATE	FEBRUARY 2026				
	PROJECT NUMBER	703222-04-001				

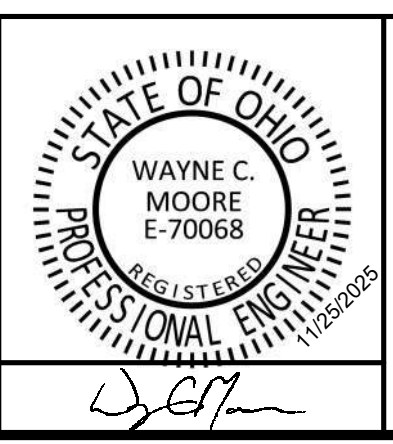

**WATER SYSTEM IMPROVEMENTS**

CONTRACT B NEW BOOSTER STATION AND TREATMENT PLANT IMPROVEMENTS  
VILLAGE OF HOLTGATE OHIO

**BOOSTER STATION  
POWER PLAN**

SHEET NO.	<b>6E1</b>
PAGE NUMBER	<b>37</b>
DDAGW-4113	02/25/2026



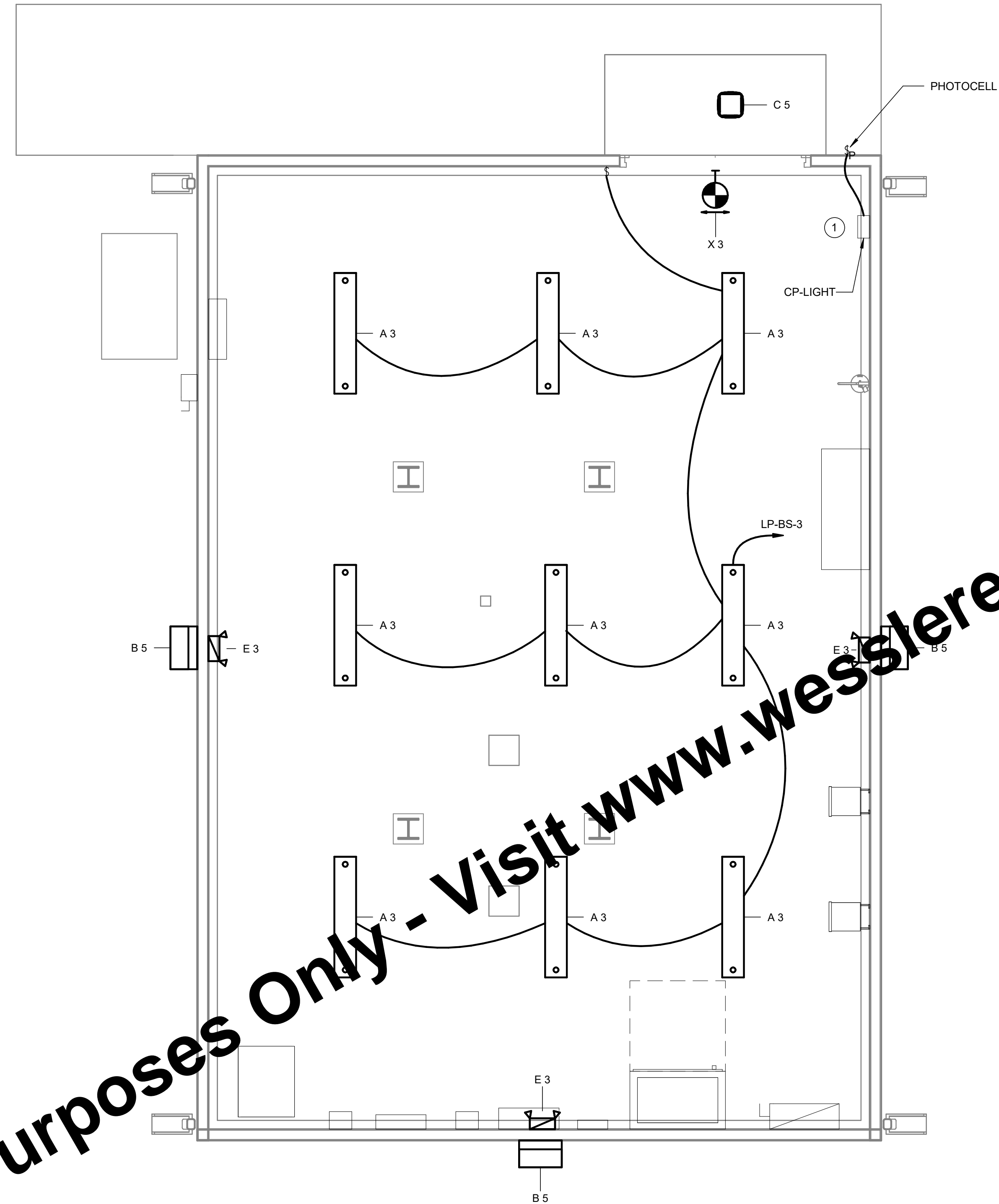
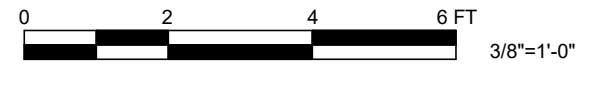
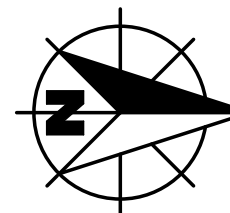

**BOOSTER STATION LIGHTING PLAN**  
SCALE: 3/8" = 1'-0"

- KEYED NOTES:** #
1. CP-LIGHT TO HAVE A SINGLE (1) HOA SWITCH FOR OUTDOOR LIGHTING CONTROL. HOA SWITCH SHALL CONTROL BOOSTER STATION OUTDOOR LIGHTING. HOA SWITCH WILL HAVE 3 POSITIONS, LIGHTS ON, LIGHTS OFF, LIGHTS AUTO (PHOTOCELL). SEE DETAIL ON SHEET 8E6.

For Viewing Purposes Only - Visit [www.wesslerengineering.com](http://www.wesslerengineering.com) to Purchase

Plotted: 1/22/2026 9:12:24 AM C:\Autodesk\Revit Local\703222-BS-NEW-AGENT-25\_CurtisGramann.rvt

SCALE VERIFICATION	DRAWN BY	JLK	NO.	DATE	INITIALS	REVISION DESCRIPTION
BAR IS ONE INCH LONG ON ORIGINAL DRAWING 	CHECKED BY	JAP				
	APPROVED BY	WCM				
	ISSUE DATE	FEBRUARY 2026				
	PROJECT NUMBER	703222-04-001				

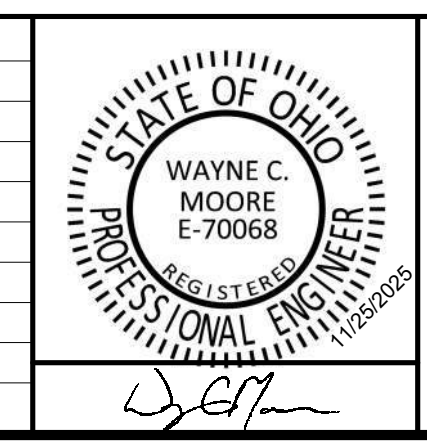

**WATER SYSTEM IMPROVEMENTS**  
CONTRACT B NEW BOOSTER STATION AND TREATMENT PLANT IMPROVEMENTS  
VILLAGE OF HOGGATE OHIO

**BOOSTER STATION LIGHTING PLAN**

SHEET NO.  
**6E2**

PAGE NUMBER  
**38**

DDAGW-4113  
02/25/2026



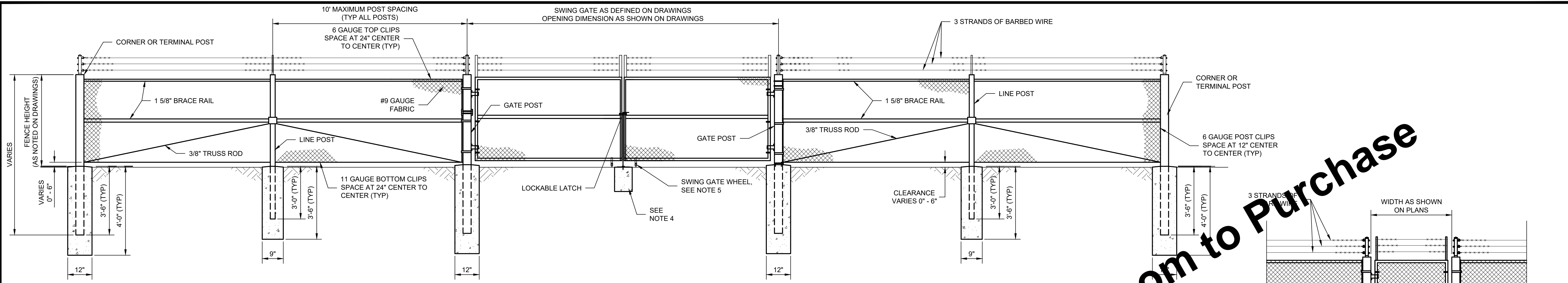

**NOTES:**

1. TERMINAL POSTS SHALL BE USED AT EACH FENCE CORNER OR END. GATE POSTS SHALL BE USED AT EACH GATE OPENING. LINE POSTS SHALL BE USED AT MAXIMUM 10' SPACING WHERE TERMINAL, GATE OR PULL POSTS ARE NOT REQUIRED.
2. PULL POSTS SHALL BE SPACED AT A MAXIMUM OF 500' ON LONG STRAIGHT RUNS ALONG CONSISTENT GRADES, AT EVERY HORIZONTAL BEND GREATER THAN 10' WHERE TERMINAL POSTS ARE NOT REQUIRED, AND AT EVERY MAJOR CHANGE OF GRADE. PULL POSTS SHALL NOT BE USED AS GATE OR TERMINAL POSTS.
3. ALL CONCRETE IN POST ANCHORS SHALL CONFORM TO THE SPECIFICATIONS.
4. PROVIDE 8" X 8" X 12" DEEP CONCRETE BLOCKING FOR GATE LATCH.

**DOUBLE GATE  
CHAIN LINK FENCE INSTALLATION**  
SCALE: NONE

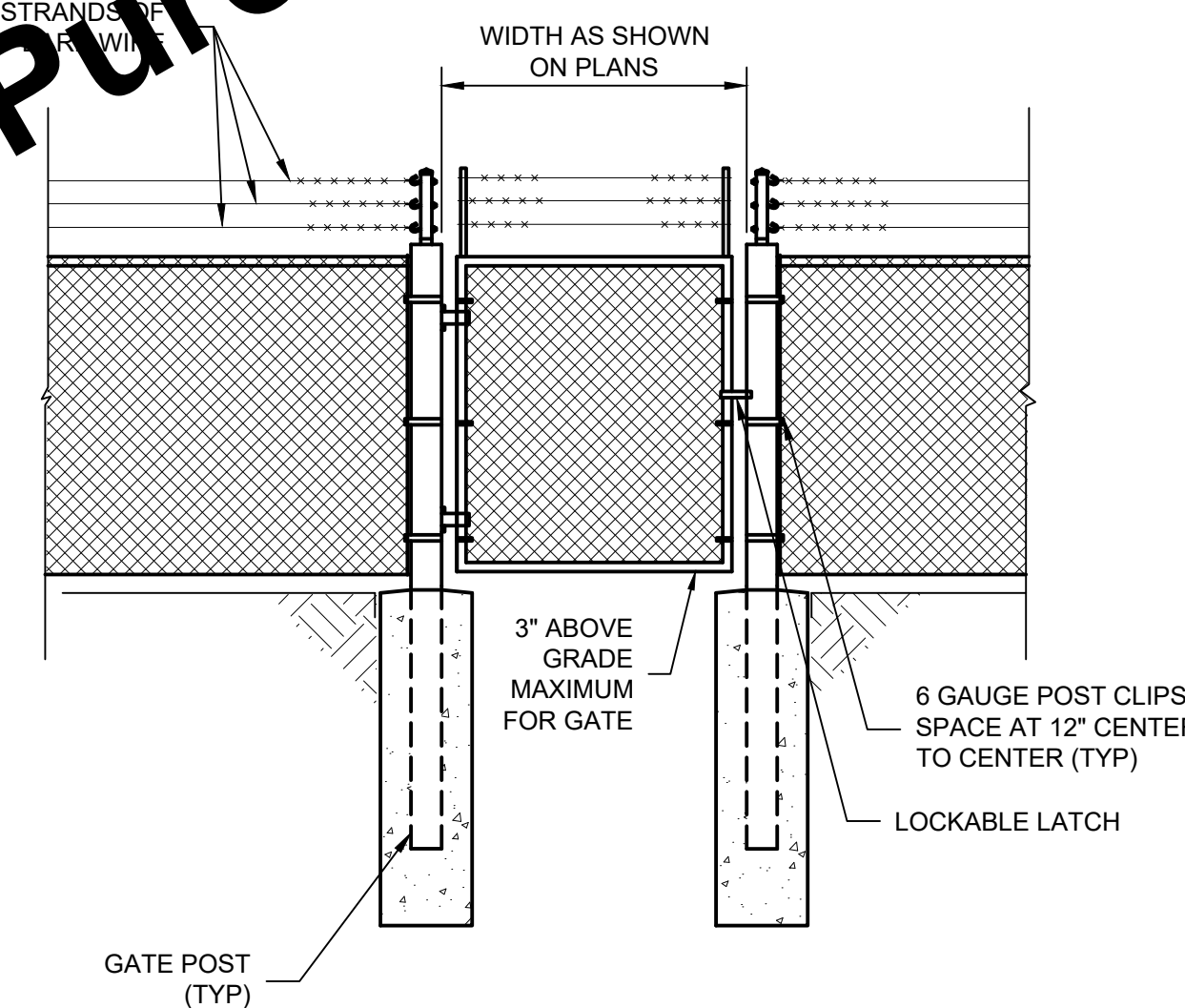

**PEDESTRIAN SWING GATE**  
SCALE: NONE

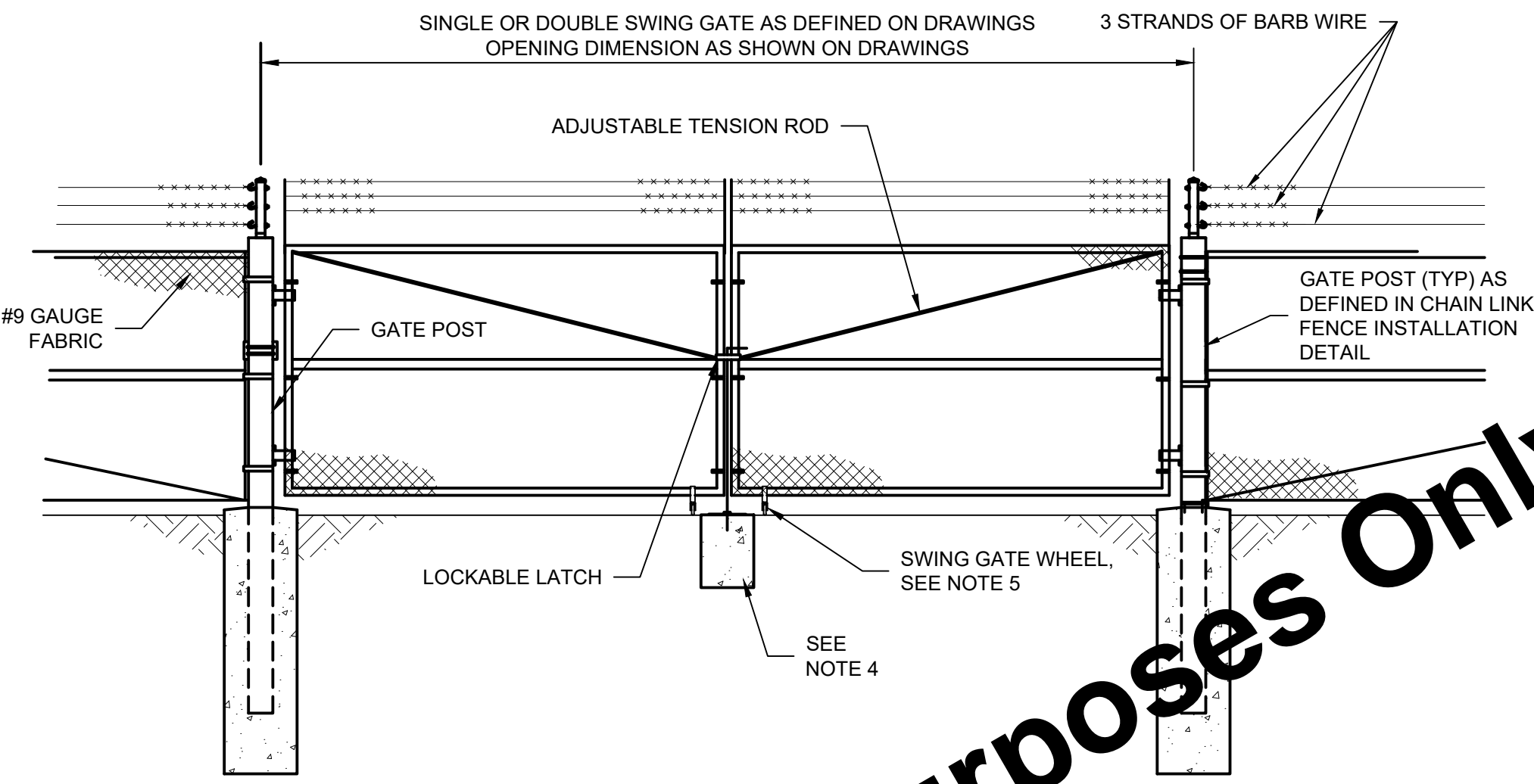

**NOTES:**

1. TERMINAL POSTS SHALL BE USED AT EACH FENCE CORNER OR END. GATE POSTS SHALL BE USED AT EACH GATE OPENING. LINE POSTS SHALL BE USED AT MAXIMUM 10' SPACING WHERE TERMINAL, GATE OR PULL POSTS ARE NOT REQUIRED.
2. PULL POSTS SHALL BE SPACED AT A MAXIMUM OF 500' ON LONG STRAIGHT RUNS ALONG CONSISTENT GRADES, AT EVERY HORIZONTAL BEND GREATER THAN 10' WHERE TERMINAL POSTS ARE NOT REQUIRED, AND AT EVERY MAJOR CHANGE OF GRADE. PULL POSTS SHALL NOT BE USED AS GATE OR TERMINAL POSTS.
3. ALL CONCRETE IN POST ANCHORS SHALL CONFORM TO THE SPECIFICATIONS.
4. PROVIDE 8" X 8" X 12" DEEP CONCRETE BLOCKING FOR GATE LATCH.
5. PROVIDE 8" X 8" X 12" DEEP CONCRETE BLOCKING FOR GATE LATCH.

**DRIVEWAY SWING GATE INSTALLATION**  
SCALE: NONE

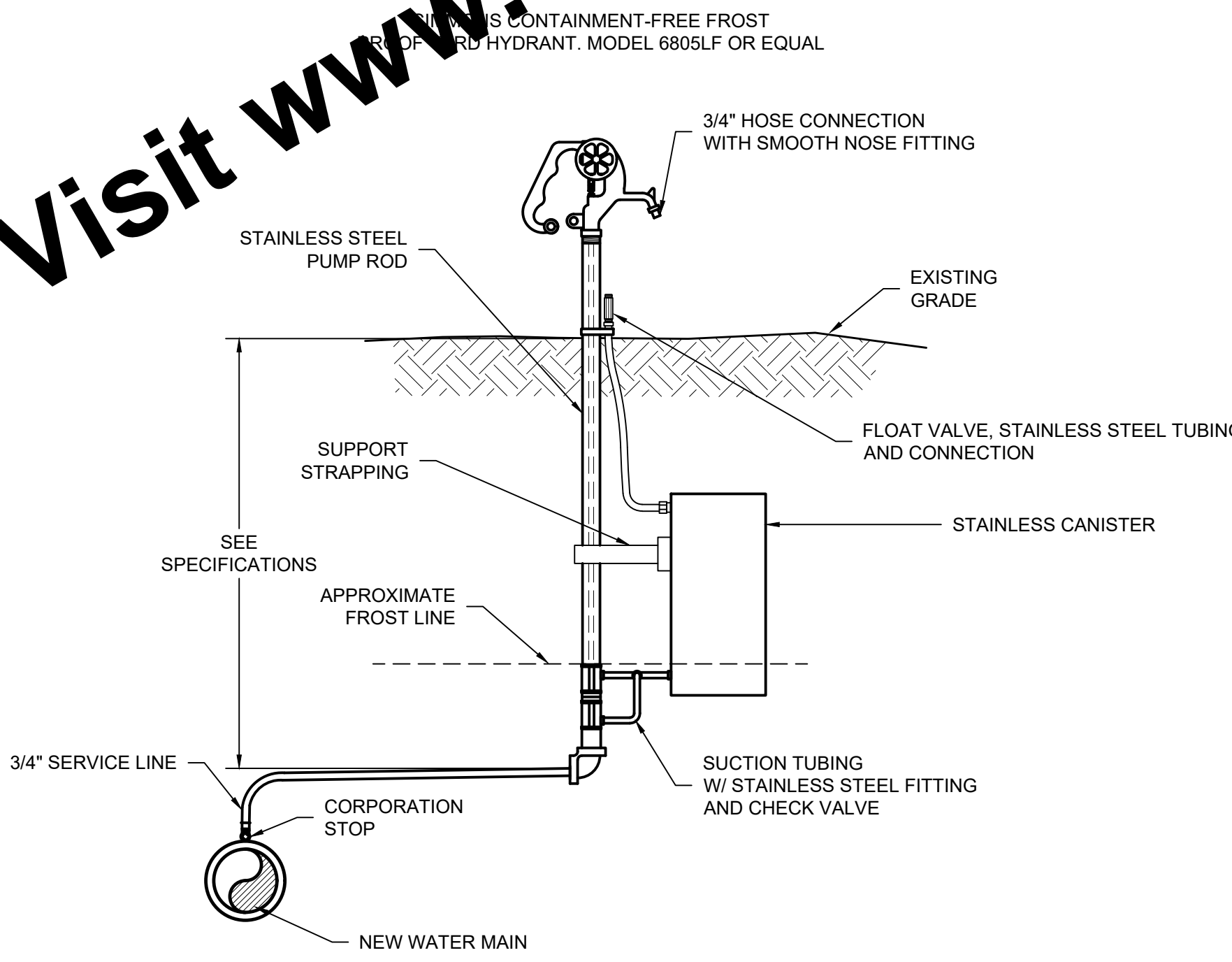

**YARD HYDRANT**  
SCALE: NONE

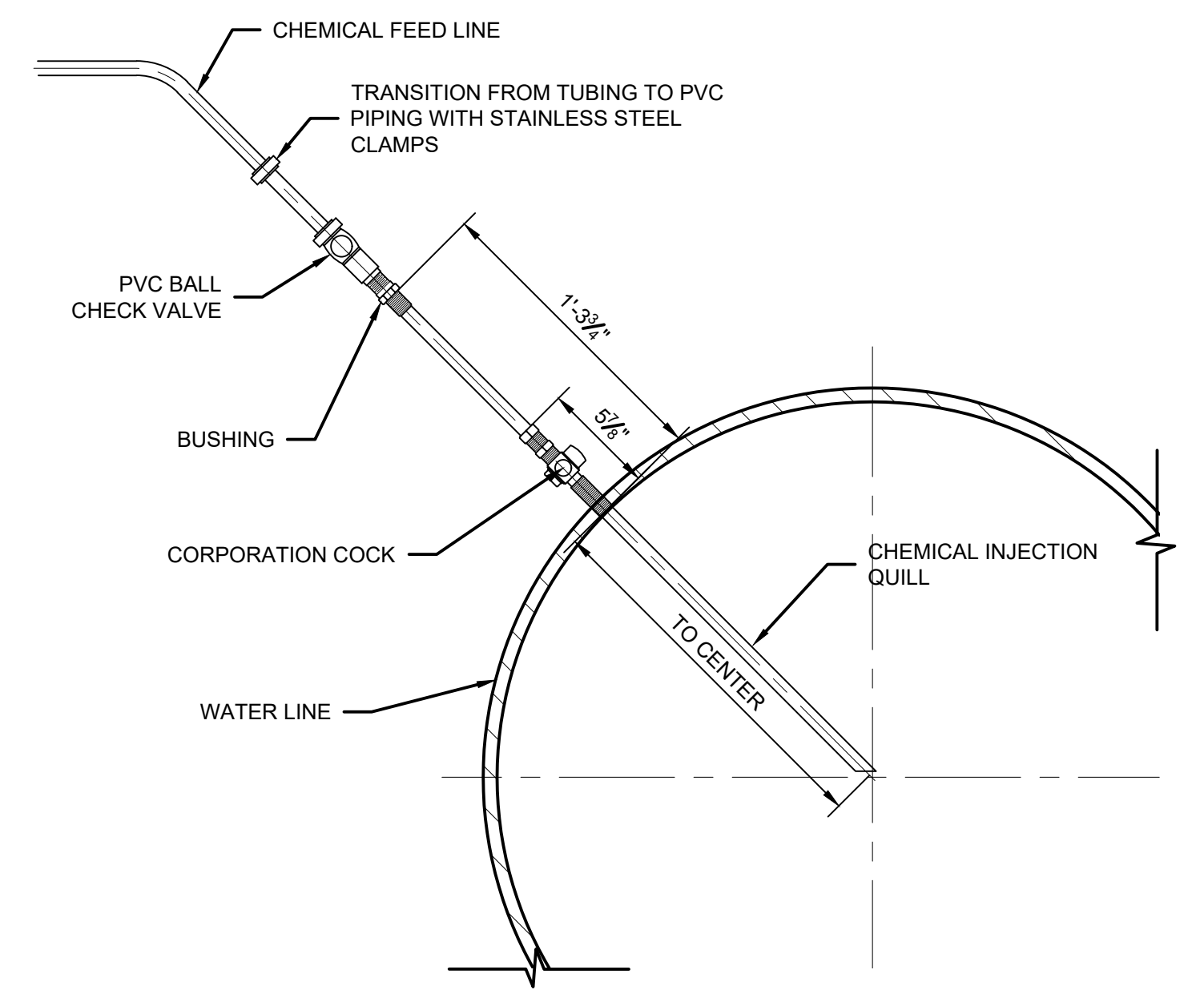

**CHEMICAL INJECTION CONNECTION DETAIL**  
SCALE: NONE

Drawing: X:\Highgate\_Oh\703222\_Highgate\_WTP\Contract B - Booster Station and WTP\DWG\Sheets\703222-04.dwg | Layout: 7MD1 | Plotted: 02/09/2026 @ 09:26:25 | LasSaverby\_Cullis

For Viewing Purposes Only - Visit [www.wesslerengineering.com](http://www.wesslerengineering.com) to Purchase

SCALE VERIFICATION	DRAWN BY	CLG	NO.	DATE	INITIALS	REVISION DESCRIPTIONS
BAR IS ONE INCH LONG ON ORIGINAL DRAWING	CHECKED BY	MAP				
	APPROVED BY	AMS				
	ISSUE DATE	FEBRUARY 2026				
	PROJECT NUMBER	703222-04-001				

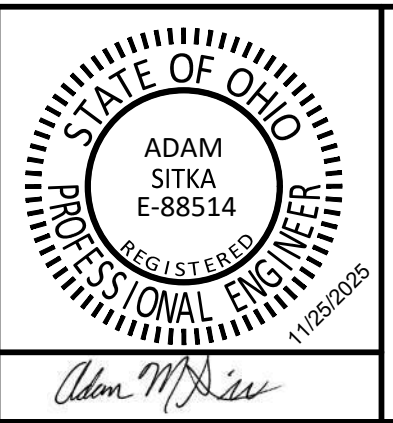

<b>WATER SYSTEM IMPROVEMENTS</b>
CONTRACT B NEW BOOSTER STATION AND WATER TREATMENT PLANT IMPROVEMENTS VILLAGE OF HOGATE, OHIO
<b>MISCELLANEOUS DETAILS</b>

SHEET NO. <b>7MD1</b>
PAGE NO. <b>39</b>
DDAGW-4113

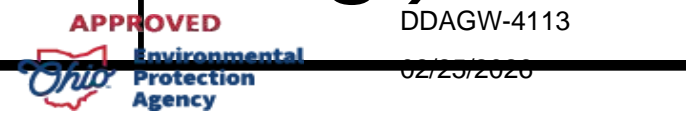

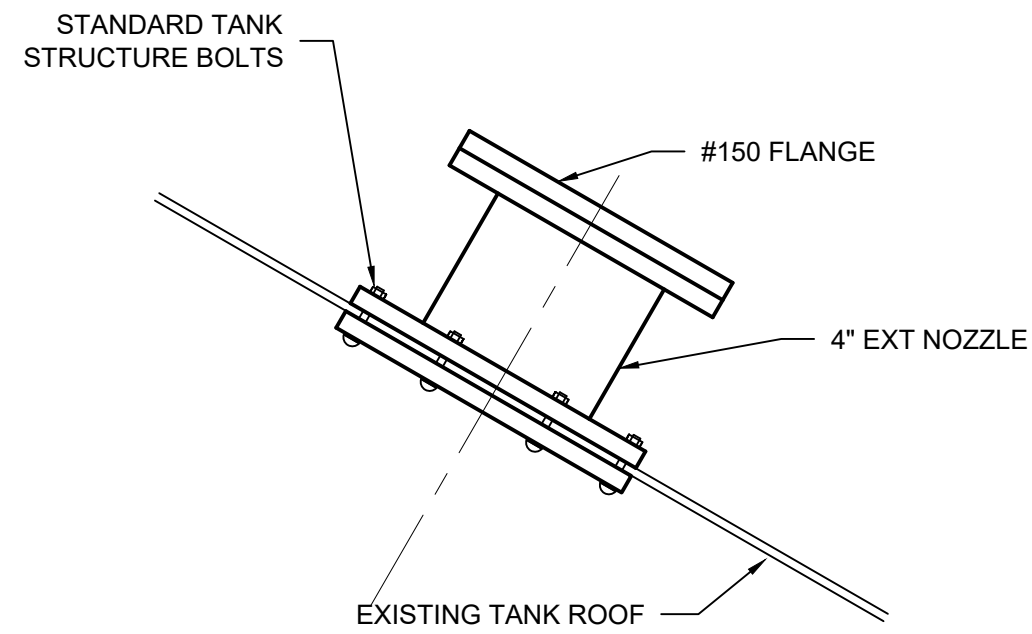

**ROOF MOUNTED VENTILATION EQUIPMENT DETAIL**  
SCALE: NONE

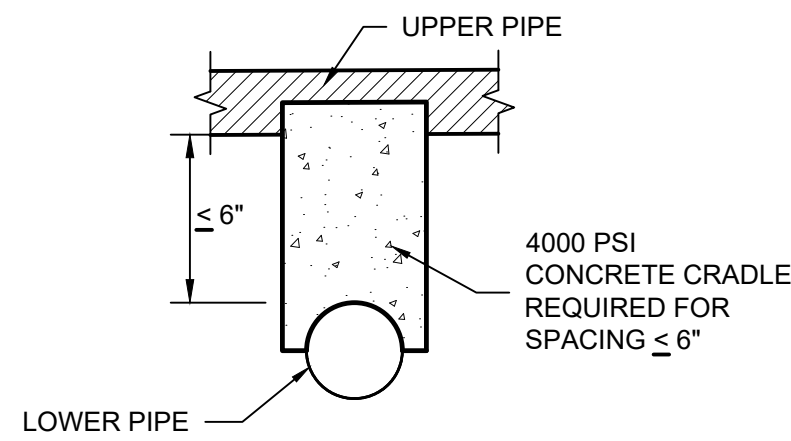

**CONCRETE CRADLE**  
SCALE: NONE

NOTES:  
1. IF THE EXISTING PIPE IS DAMAGED OR IN POOR CONDITION, AS DETERMINED BY THE OWNER OR ENGINEER, THE CONTRACTOR SHALL REPAIR THE PIPE PRIOR TO CONCRETE CRADLE PLACEMENT.

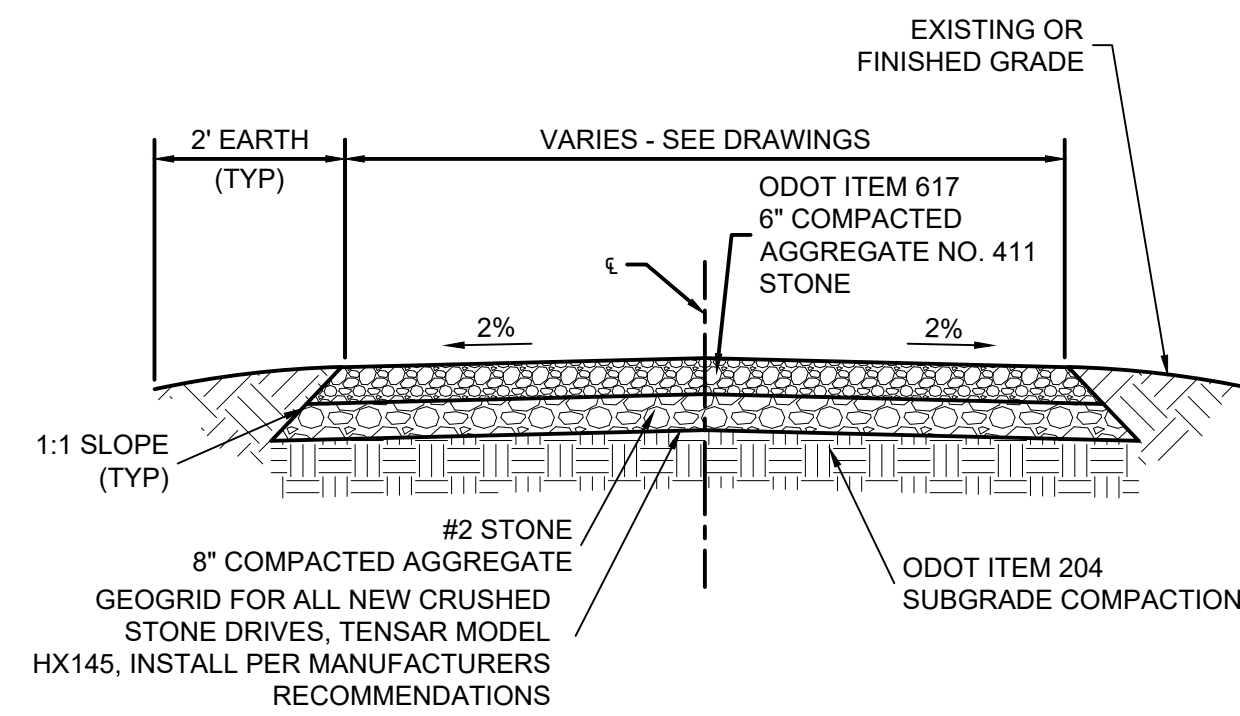

**CRUSHED STONE DRIVE**  
SCALE: NONE

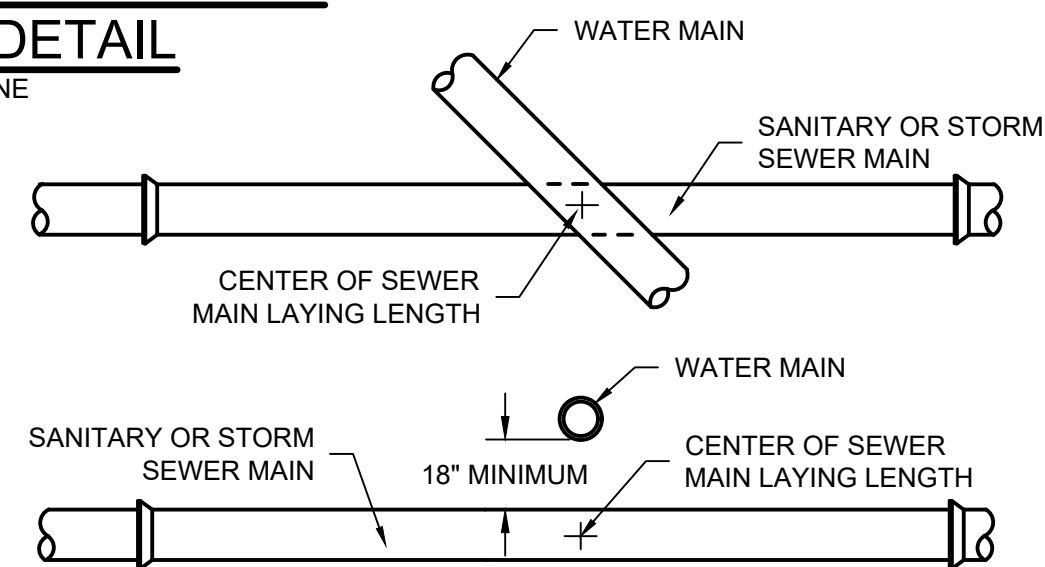

**MINIMUM CROSSOVER AND SEPARATION REQUIREMENTS FOR SEWER AND WATER MAINS**  
SCALE: NONE

NOTES:  
1. WATER MAIN AND SEWER MINIMUM SEPARATION: 18" VERTICAL SEPARATION 10'-0" HORIZONTAL SEPARATION.

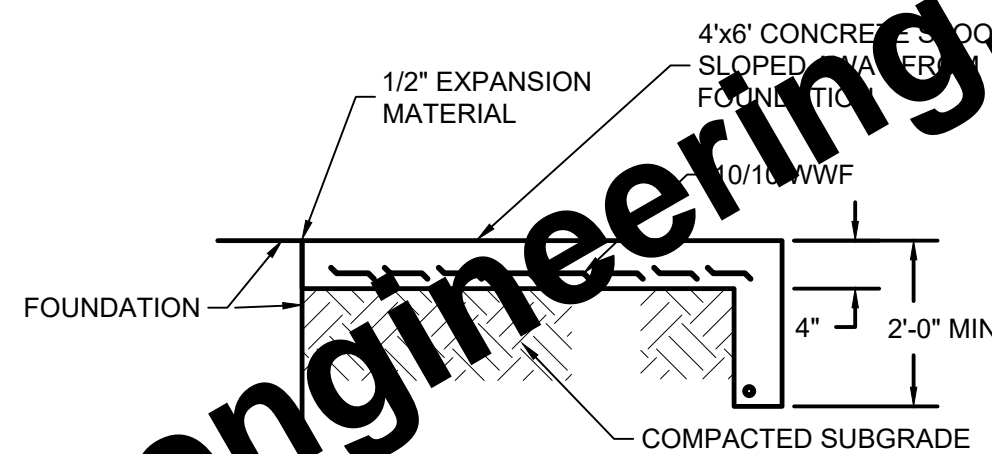

**CONCRETE STOOP**  
SCALE: NONE

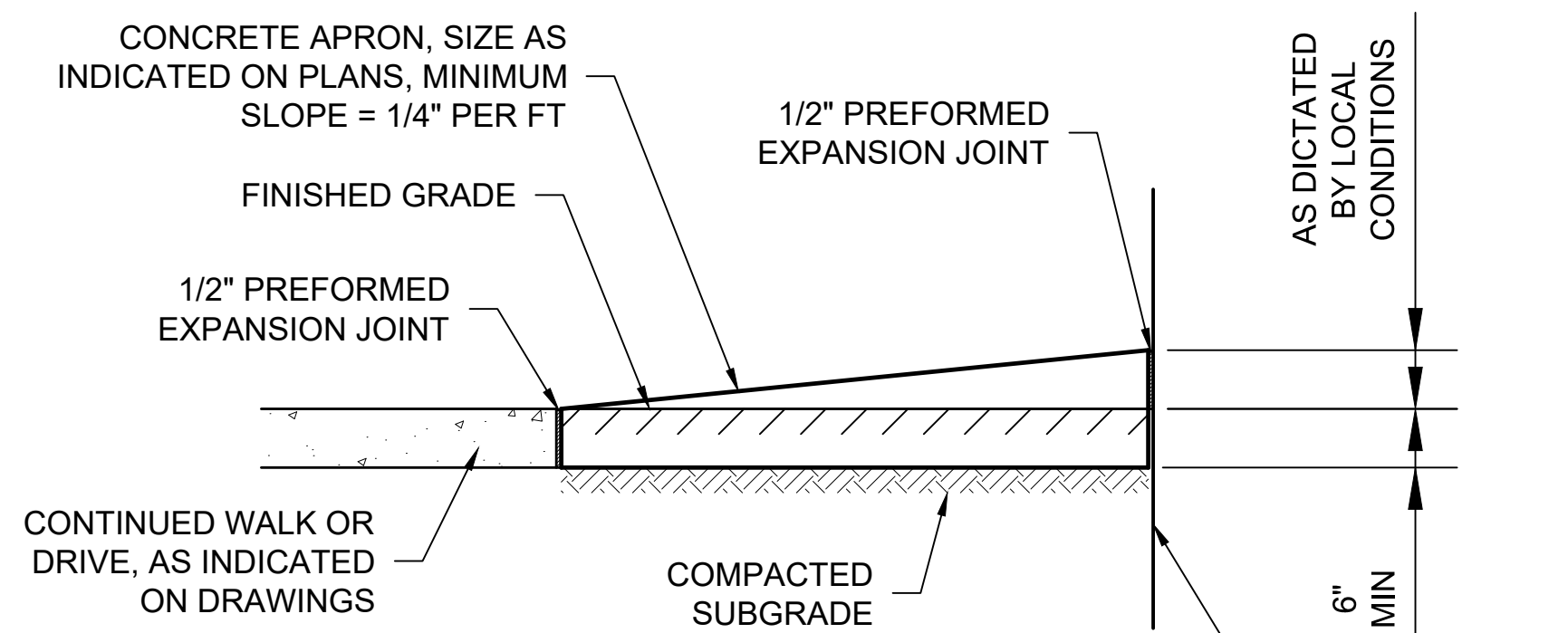

**CONCRETE APRON**  
SCALE: 3/4" = 1'-0"

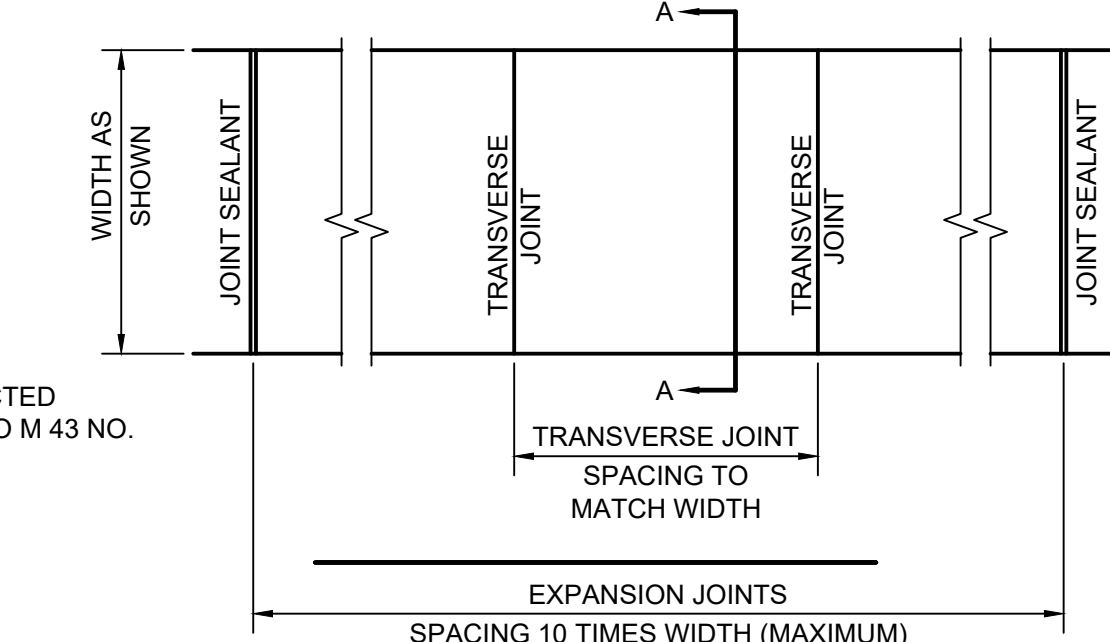
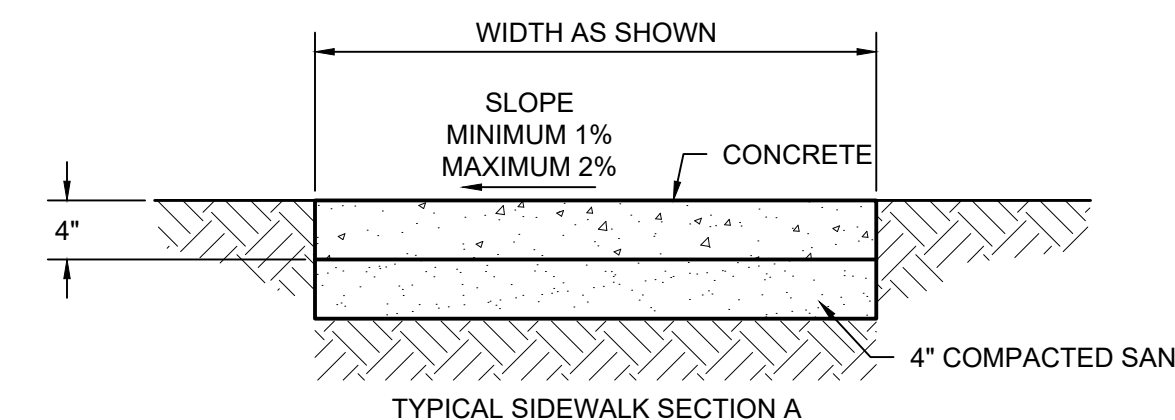

**CONCRETE SIDEWALK**  
SCALE: NONE

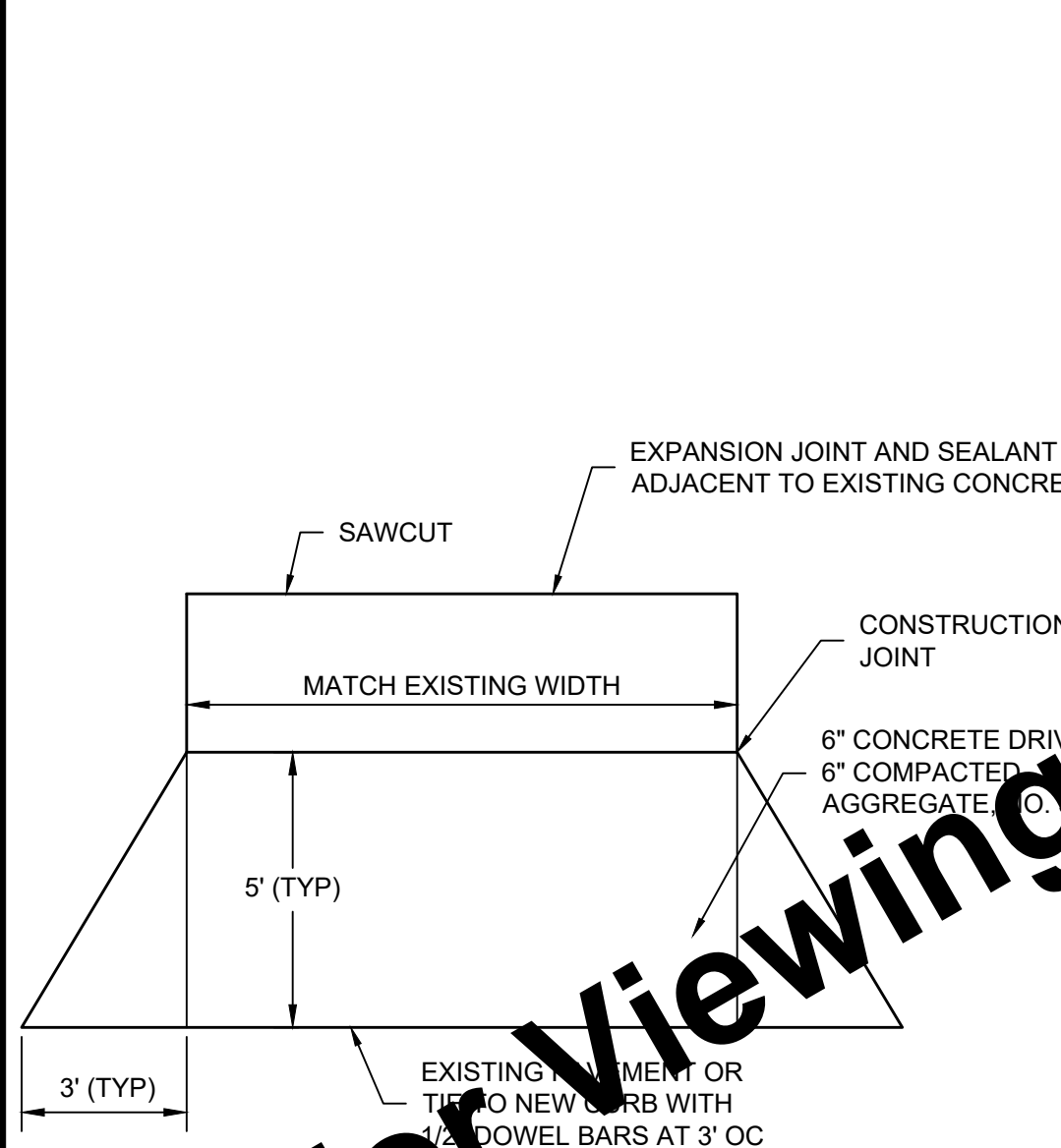

**CONCRETE DRIVE APPROACH**  
SCALE: NONE

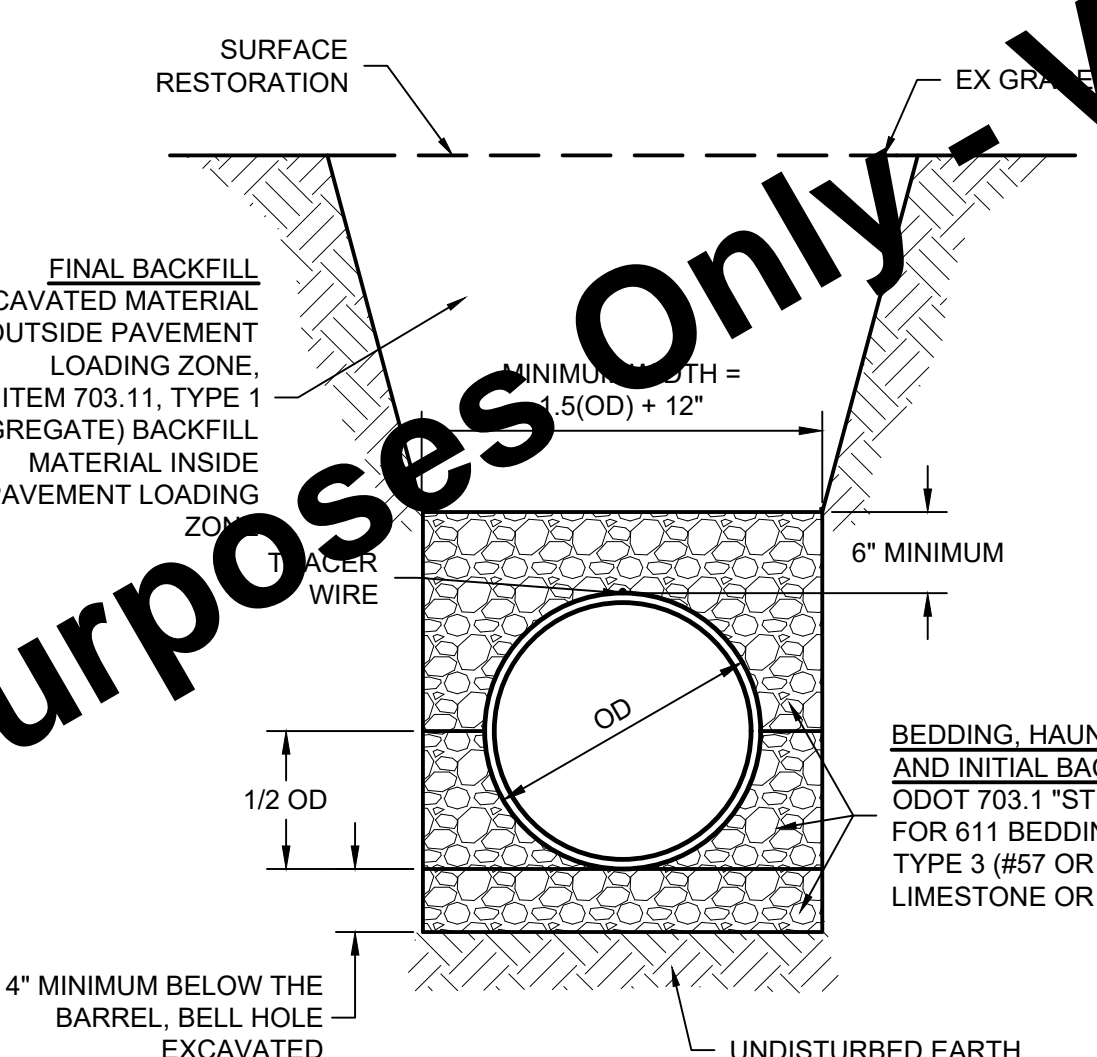

**PLASTIC PIPE TRENCH (PRESSURE)**  
SCALE: NONE

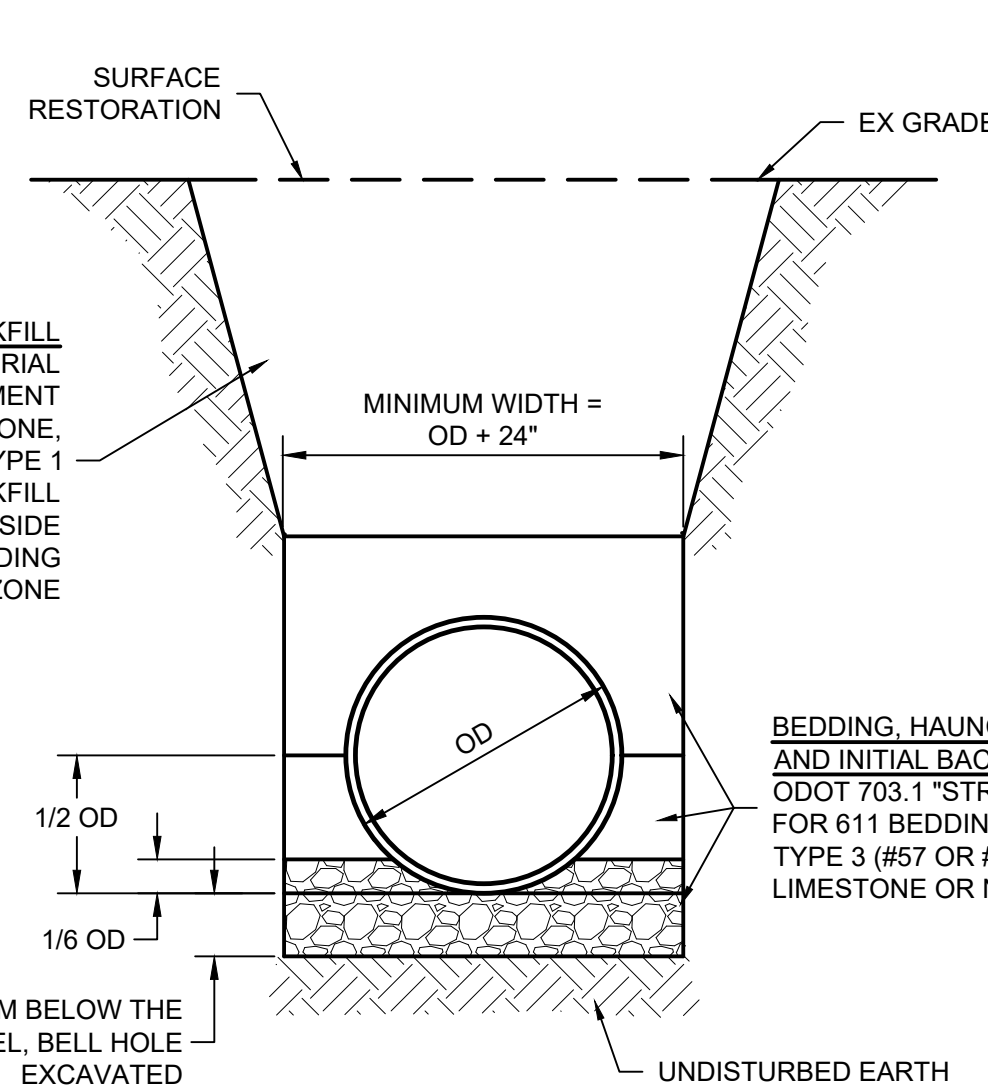

**DUCTILE IRON (DI) PIPE TRENCH**  
SCALE: NONE

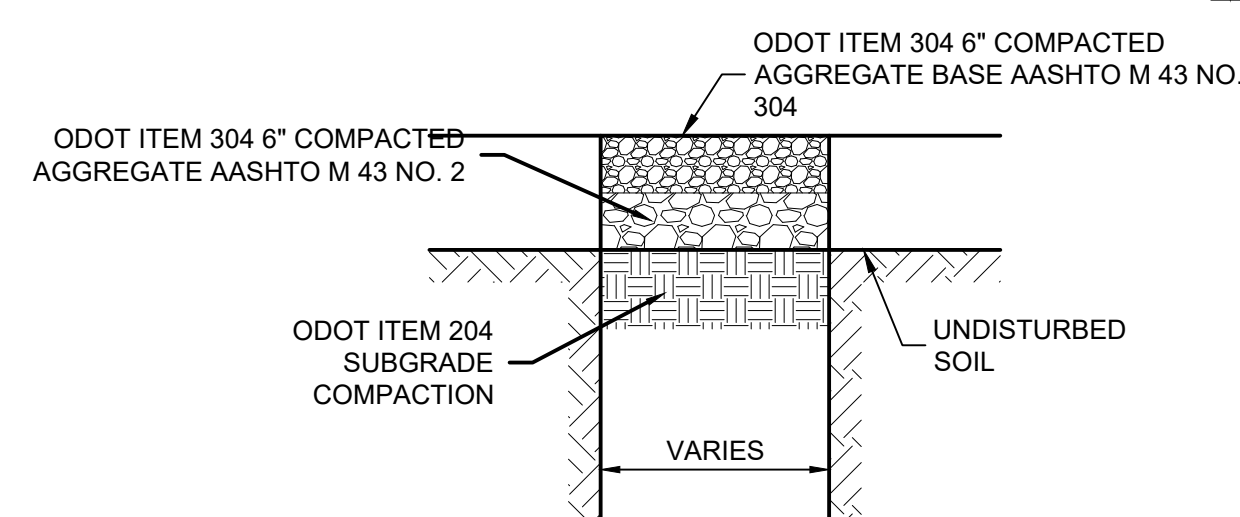

**CRUSHED STONE SURFACE**

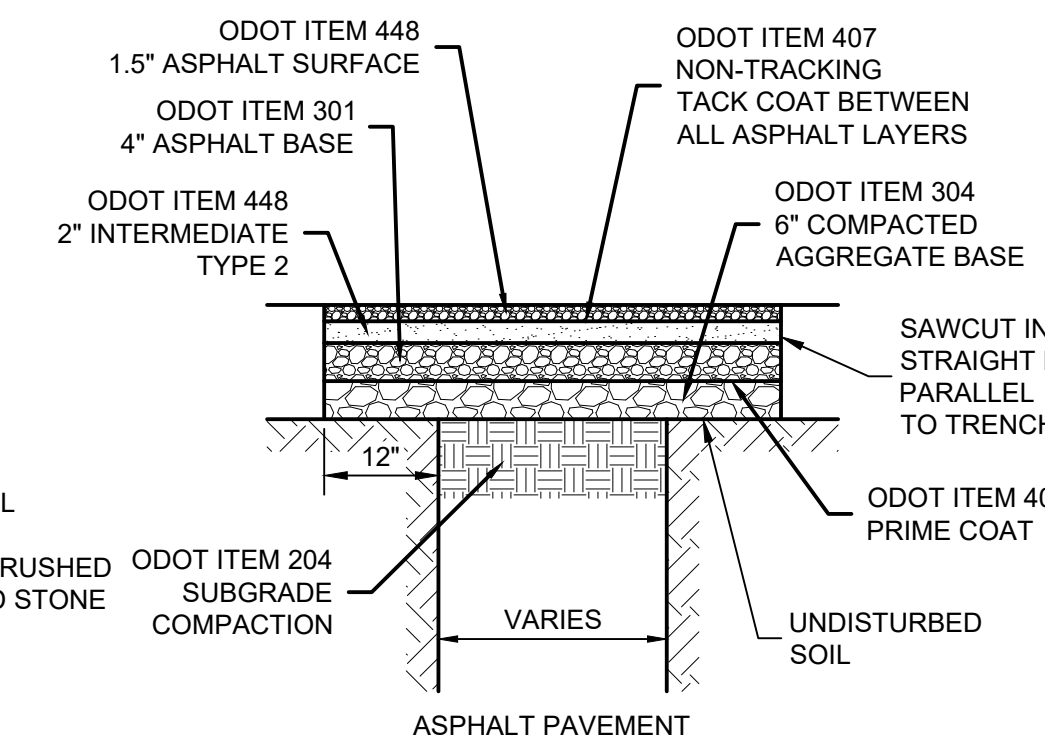

**PAVEMENT REPAIR**  
SCALE: NONE

NOTE:  
1. TO SPECIFIER: HMA, TYPE B RELATES TO AN EQUIVALENT SINGLE AXLE LOAD (ESAL) OF <3,000,000, AVERAGE ANNUAL DAILY TRAFFIC (AADT) OF <15,000, AND AVERAGE ANNUAL DAILY TRUCK TRAFFIC (AADTT) OF <1,700. IF THE PROJECT EXPERIENCES CONDITIONS OUTSIDE THESE PARAMETERS, A TYPE C OR TYPE D HMA MAY BE REQUIRED.

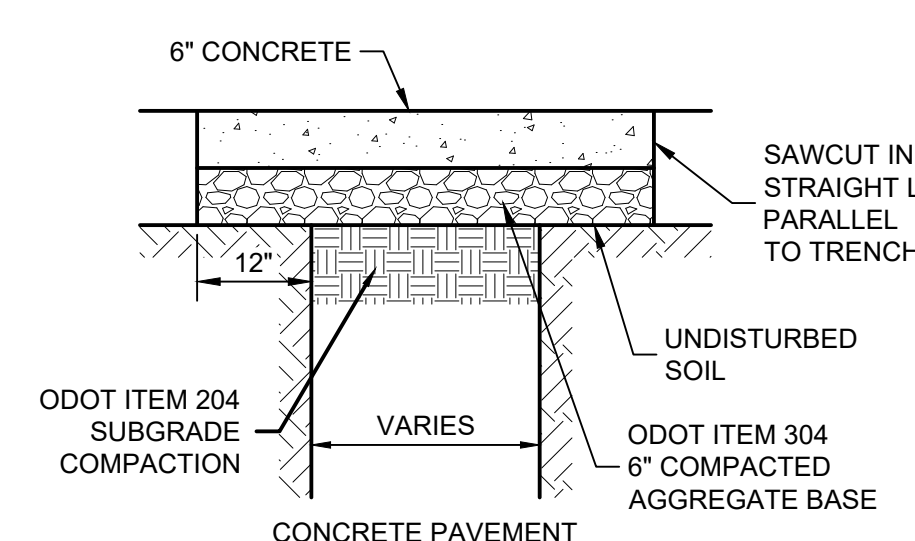

**CONCRETE PAVEMENT**

SCALE VERIFICATION	DRAWN BY	CLG	NO.	DATE	INITIALS	REVISION DESCRIPTIONS
BAR IS ONE INCH LONG ON ORIGINAL DRAWING	CHECKED BY	MAP				
	APPROVED BY	AMS				
	ISSUE DATE	FEBRUARY 2026				
	PROJECT NUMBER	703222-04-001				

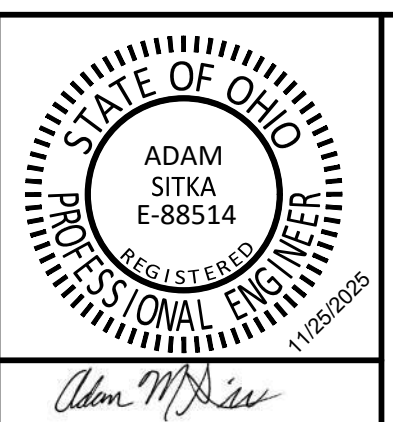

**WATER SYSTEM IMPROVEMENTS**  
CONTRACT B NEW BOOSTER STATION AND WATER TREATMENT PLANT IMPROVEMENTS  
VILLAGE OF HOLGATE, OHIO

**MISCELLANEOUS DETAILS**

SHEET NO.  
**7MD2**

PAGE NO.  
**40**

DDAGW-4113  
02/23/2026



Drawing: X:\Highgate\_OH\703222\_Highgate WTP\Contract B - Booster Station and WTP\DWG Sheets\703222-04-001.dwg | Layout: 7MD2 | Plotted: 01/29/26 @ 10:45:11 | LasSeraSeraBy: CurisGG

# WATER SYSTEM IMPROVEMENTS NEW BOOSTER STATION AND WATER TREATMENT PLANT VILLAGE OF HOLGATE, OHIO

ELVA POSADAS-WYANDT, MAYOR  
JASON MICHEL, VILLAGE ADMINISTRATOR

### VILLAGE COUNCIL

CHRIS HEALY, PRESIDENT  
JAMIE HOHENBERGER, MEMBER  
JEFFERY ROTHMAN, MEMBER  
NICHOLAS STEPHEY, MEMBER  
MIKE MEDINA, MEMBER  
RICARDO VALDEZ, MEMBER

### CONSULTING ENGINEER

WESSLER ENGINEERING, INC.  
INDIANAPOLIS, INDIANA  
BLUFTON, OHIO

### GENERAL CONTRACTOR

COMPANY  
CITY, STATE

CONSTRUCTED MONTH, YEAR

#### NOTES:

- CAST THE PROJECT IDENTIFICATION PLAQUE IN ALUMINUM WITH SATIN FINISH HELVETICA STYLE LETTERS AND A RAISED EDGE BORDER STYLE. PROVIDE THE BACKGROUND WITH A PEBBLE TEXTURE
- PLAQUE FINISH: ANODIZED BLACK, GRAY OR BRONZE TONED COLORED FINISH. SPRAY THE ENTIRE TABLET WITH A CLEAR LACQUER FINISH.
- BACKGROUND FINISH COLOR: SELECTED BY THE OWNER.
- SECURELY MOUNT THE PLAQUE WITH EXPANSION BOLTS USING ROSETTE COVERS.
- SUBMIT A RUBBING AND OTHER NECESSARY INFORMATION TO THE ENGINEER FOR APPROVAL.

### DEDICATION PLAQUE DETAIL

SCALE: NONE

FEET OF RESTRAINED PIPE @ 150 PSI (A) ON EACH SIDE OF FITTING	
FITTING TYPE	WATER MAIN SIZE
11 1/4" HORIZ BEND	3
22 1/2" HORIZ BEND	6
45° HORIZ BEND	11
90° HORIZ BEND	27
11 1/4" VERT BEND	6
22 1/2" VERT BEND	11
45° VERT BEND	23
90° VERT BEND	55
DEAD END	55
VALVES AND PLUGS	55
TEE OUTLET	33

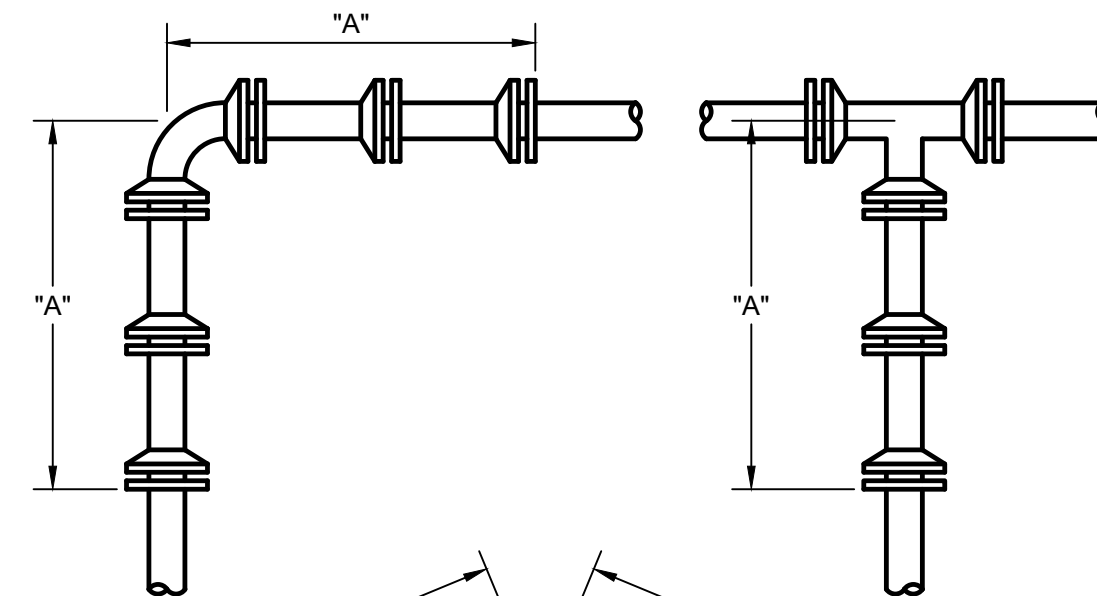

### WATER MAIN RESTRAINED PIPING

SCALE: NONE

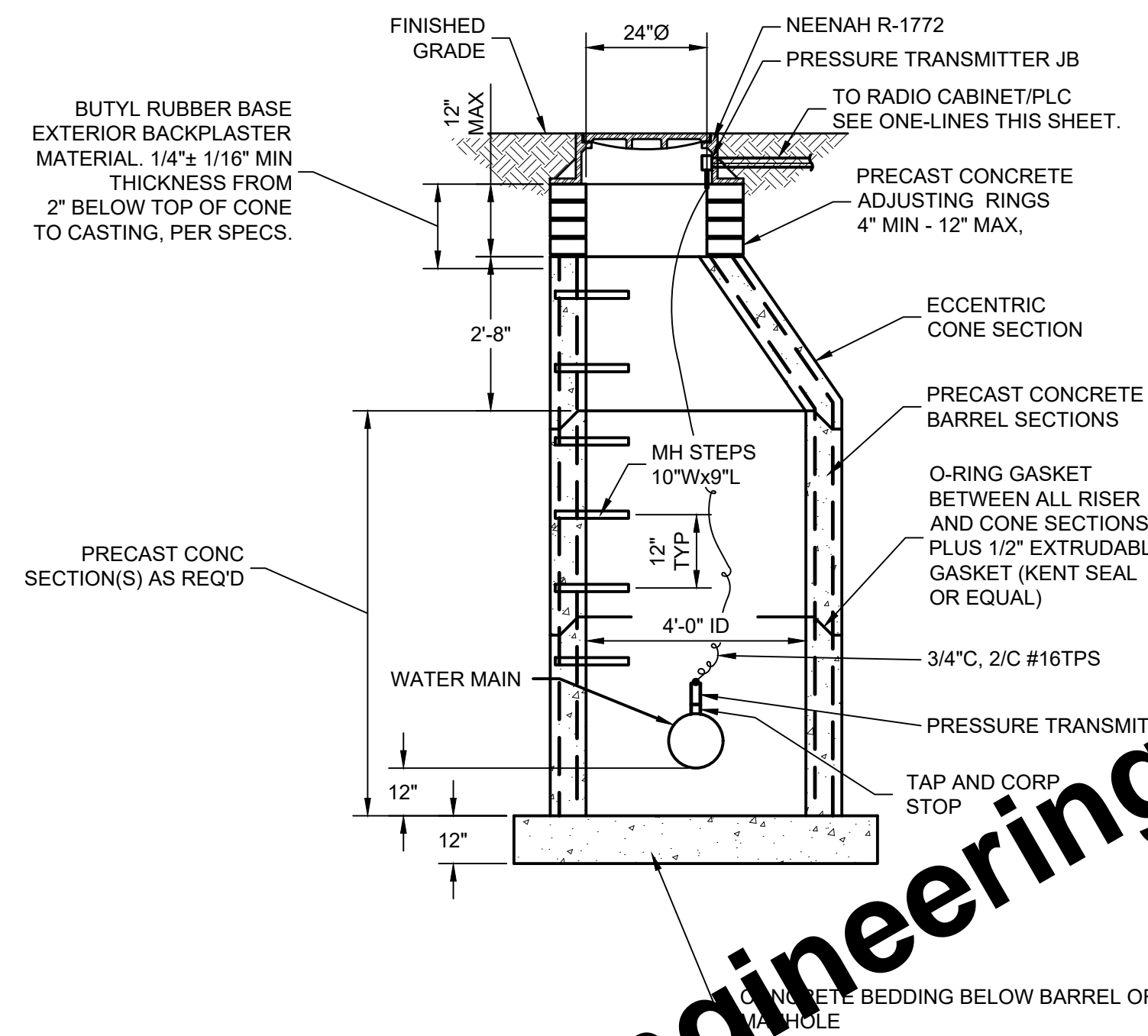

#### NOTES:

- STEPS SHALL BE POLYPROPYLENE REINFORCING, OR AN APPROVED NON-CORROSIVE FIBERGLASS REINFORCING. THE COPOLYMER POLYPROPYLENE SHALL MEET THE REQUIREMENTS OF ASTM D-3011. REINFORCING WITH DEFORMED 1/2 INCH MINIMUM DIAMETER REINFORCING STEEL SHALL BE USED IN ACCORDANCE WITH THE REQUIREMENTS OF ASTM A-615, GRADE 60. NON-COATED CAST IRON STEPS ARE NOT ACCEPTABLE.
- DOGHOUSE OPENING MAY ONLY BE USED WHEN PLACING A NEW MANHOLE OVER AN EXISTING LINE; OTHERWISE, THE OPENING MUST BE CAST.

### PRESSURE TRANSMITTER MANHOLE

SCALE: NONE

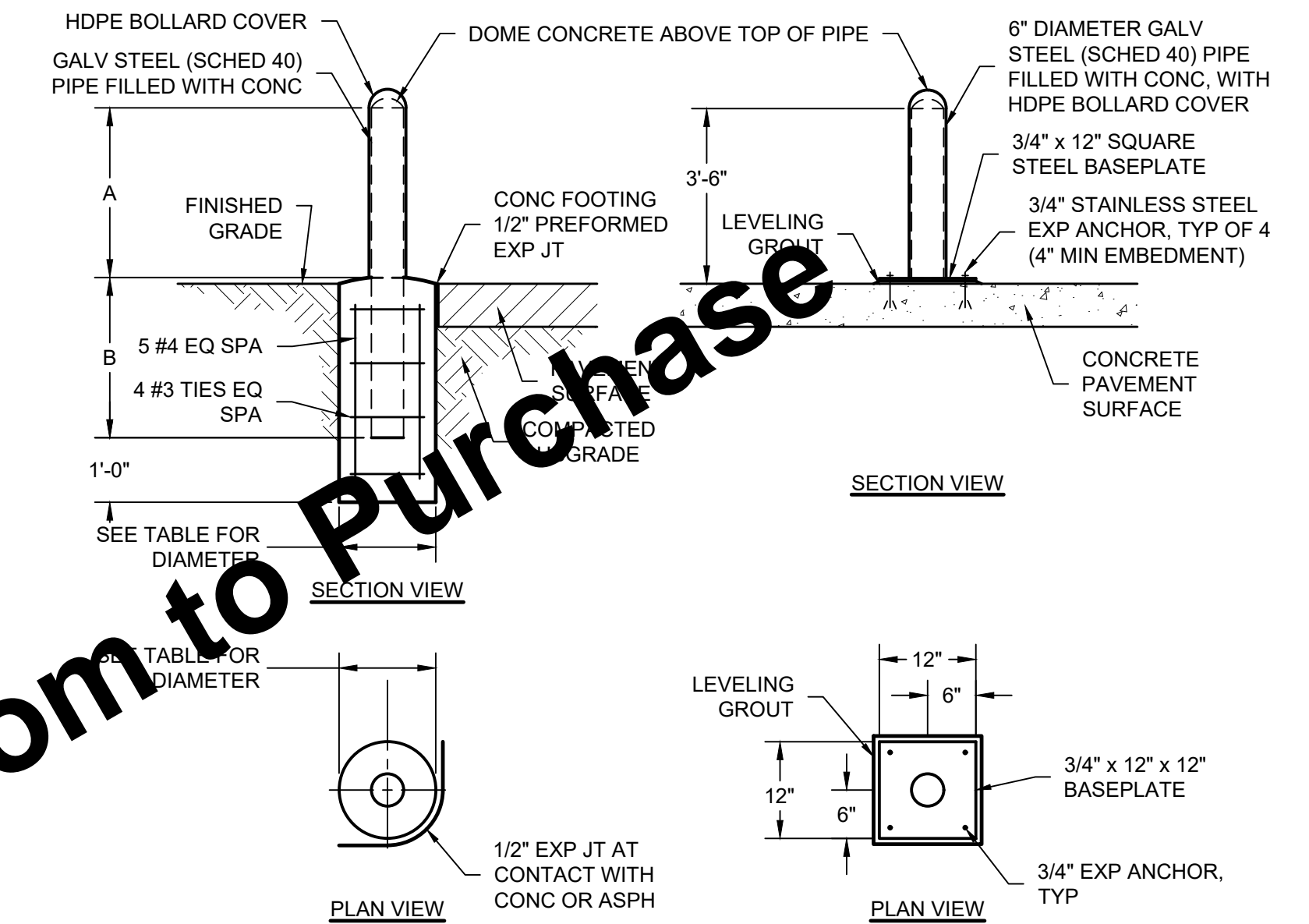

### TYPES 1 AND 2 BOLLARDS

### TYPE 3 BOLLARD

#### NOTES:

- TYPE OF BOLLARD INSTALLED SHALL BE AS IDENTIFIED ON THE DRAWINGS OR AS DIRECTED BY THE ENGINEER.
- REFER TO SPEC 05520 FOR BOLLARD COVERS.

### BOLLARDS

	TYPE 1	TYPE 2
PIPE DIA	6"	8"
PIPE LENGTH	6'	7'
DIMENSION A	3'-6"	4'-0"
DIMENSION B	2'-6"	3'-0"
CONC FOOTING DIA	18"	24"

### BOLLARD DETAIL

SCALE: NONE

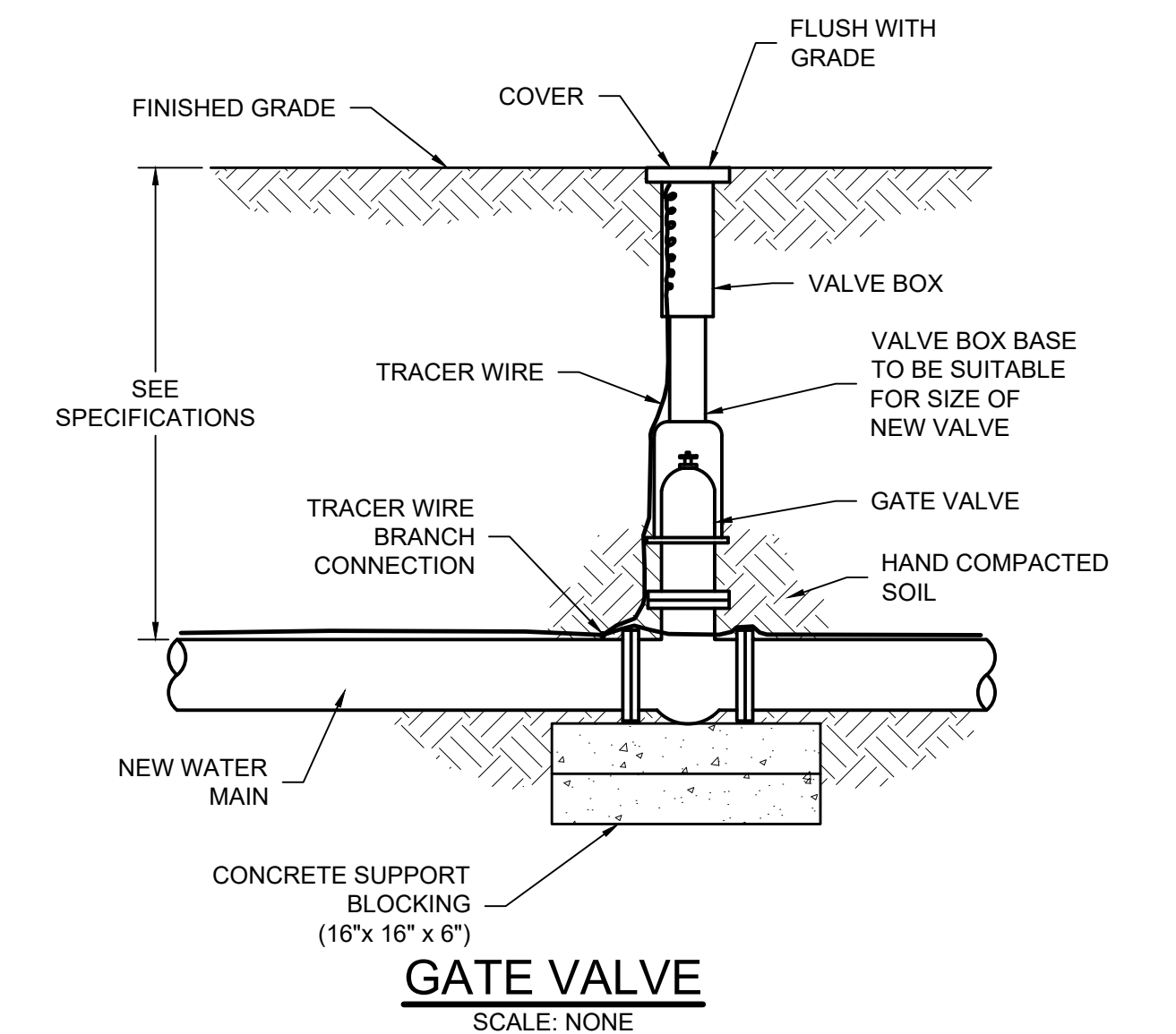

### GATE VALVE

SCALE: NONE

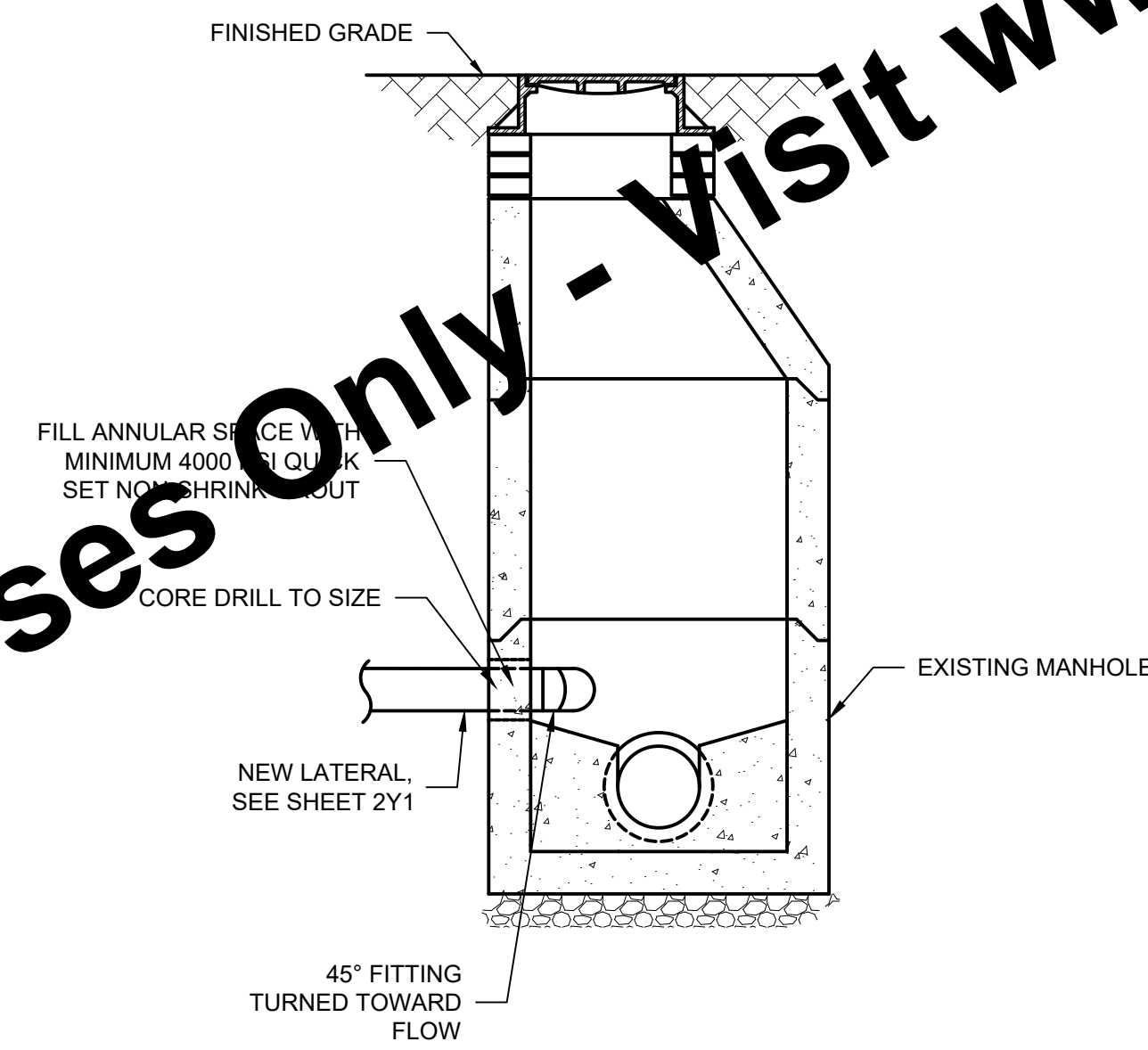

### CONNECTION AT EXISTING MANHOLE

SCALE: NONE

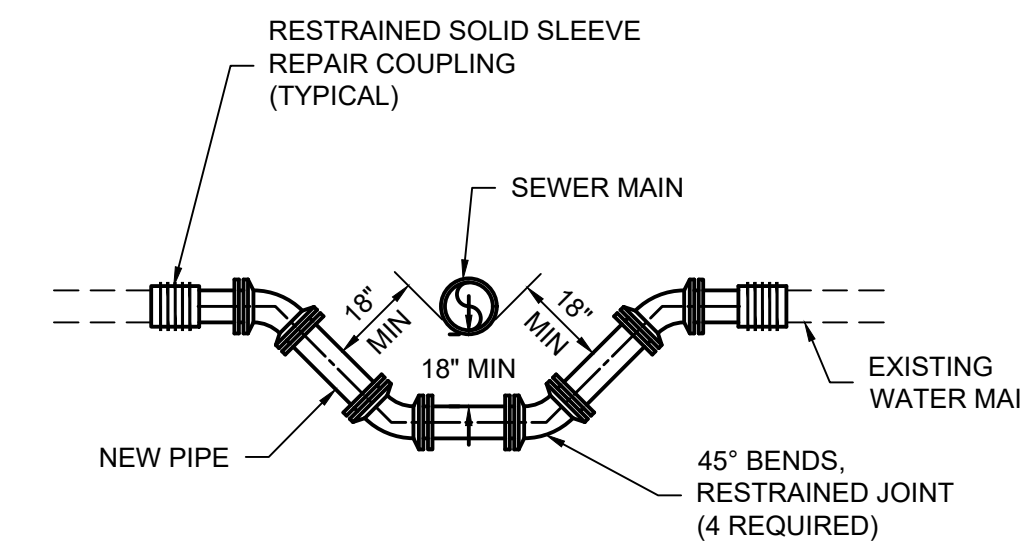

### WATER MAIN LOWERING

SCALE: NONE

For Viewing Purposes Only - Visit [www.wesslerengineering.com](http://www.wesslerengineering.com) to Purchase

SCALE VERIFICATION	DRAWN BY	CLG	NO.	DATE	INITIALS	REVISION DESCRIPTIONS
BAR IS ONE INCH LONG ON ORIGINAL DRAWING 	CHECKED BY	MAP				
	APPROVED BY	AMS				
	ISSUE DATE	FEBRUARY 2026				
	PROJECT NUMBER	703222-04-001				

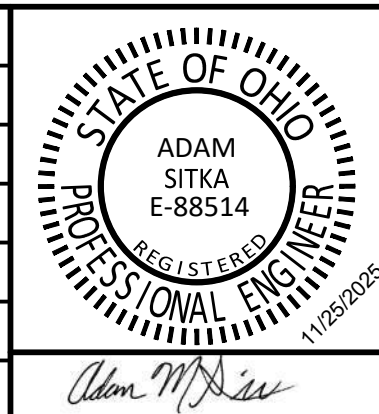

**WATER SYSTEM IMPROVEMENTS**  
CONTRACT B NEW BOOSTER STATION AND WATER TREATMENT PLANT IMPROVEMENTS  
VILLAGE OF HOLGATE, OHIO

### MISCELLANEOUS DETAILS

SHEET NO.

**7MD3**

PAGE NO.

41

DDAGW-4113



ROOM FINISH SCHEDULE							
ROOM NAME	FLOORS		WALLS		CEILING		HEIGHT
	MATERIAL	FINISH	MATERIAL	FINISH	MATERIAL	FINISH	
<b>NEW CHEMICAL BUILDING</b>							
BLEACH ROOM	CONCRETE	NON-SKID	POLY PANEL	NONE	POLY PANEL	NONE	12'-0"
PHOSPHATE ROOM	CONCRETE	NON-SKID	POLY PANEL	NONE	POLY PANEL	NONE	12'-0"
<b>NEW WATER TREATMENT BUILDING</b>							
OFFICE	CONCRETE	EPOXY RESIN	DRY WALL	COATING	ACOUSTICAL	NONE	9'-0"
RESTROOM	CONCRETE	EPOXY RESIN	DRY WALL	COATING	ACOUSTICAL	NONE	9'-0"
UTILITY ROOM	CONCRETE	EPOXY RESIN	DRY WALL	COATING	ACOUSTICAL	NONE	9'-0"
BREAKROOM	CONCRETE	EPOXY RESIN	DRY WALL	COATING	ACOUSTICAL	NONE	9'-0"
HALLWAY	CONCRETE	EPOXY RESIN	DRY WALL	COATING	ACOUSTICAL	NONE	9'-0"
GARAGE	CONCRETE	NON-SKID	POLY PANEL	NONE	POLY PANEL	NONE	15'-0"
<b>NEW BOOSTER STATION</b>							
PUMP AREA	CONCRETE	NON-SKID	POLY PANEL	NONE	POLY-PANEL	NONE	10'-0"

VALVE SCHEDULE							
NOTES: 1 THIS SCHEDULE LISTS ONLY PROCESS VALVES, 3" AND LARGER							
CHEMICAL BUILDING/HSP BUILDING							
NO.	SIZE	TYPE	FITTING	LOCATION	SERVICE	OPERATOR	REMARKS
GV-01	6"	GATE VALVE	FLANGED	HSP NO. 1	DISCHARGE	HANDWHEEL	
GV-02	6"	GATE VALVE	FLANGED	HSP NO. 2	DISCHARGE	HANDWHEEL	
GV-03	6"	GATE VALVE	FLANGED	HSP NO. 3	DISCHARGE	HANDWHEEL	
CV-04	6"	CHECK VALVE	FLANGED	HSP NO. 1	DISCHARGE	NONE	
CV-05	6"	CHECK VALVE	FLANGED	HSP NO. 2	DISCHARGE	NONE	
CV-06	6"	CHECK VALVE	FLANGED	HSP NO. 3	DISCHARGE	NONE	
BOOSTER STATION							
BF-01	8"	BUTTERFLY VALVE	FLANGED	BOOSTER PUMP BYPASS LINE	BYPASS	HANDWHEEL	
BV-01	8"	BUTTERFLY VALVE	FLANGED	BOOSTER PUMP BYPASS LINE	BYPASS	ELECTRIC ACTUATOR	NORMALLY CLOSED
BF-02	8"	BUTTERFLY VALVE	FLANGED	BOOSTER PUMP BYPASS LINE	BYPASS	HANDWHEEL	
CV-03	8"	CHECK VALVE	FLANGED	BOOSTER PUMP BYPASS LINE	BYPASS	NONE	
BF-03	6"	BUTTERFLY VALVE	FLANGED	BOOSTER PUMP NO. 1 LINE	SUCTION	HANDWHEEL	
CV-01	6"	CHECK VALVE	FLANGED	BOOSTER PUMP NO. 1 LINE	DISCHARGE	NONE	
BF-04	6"	BUTTERFLY VALVE	FLANGED	BOOSTER PUMP NO. 1 LINE	DISCHARGE	HANDWHEEL	
BF-05	6"	BUTTERFLY VALVE	FLANGED	BOOSTER PUMP NO. 2 LINE	SUCTION	HANDWHEEL	
CV-02	6"	CHECK VALVE	FLANGED	BOOSTER PUMP NO. 2 LINE	DISCHARGE	NONE	
BF-06	6"	BUTTERFLY VALVE	FLANGED	BOOSTER PUMP NO. 2 LINE	DISCHARGE	HANDWHEEL	
WATER TREATMENT PLANT VAULT							
BF-07	4"	BUTTERFLY VALVE (CONTROL VALVE)	FLANGED	8" SUPPLY LINE FROM PUMP	SUPPLY	ELECTRIC ACTUATOR	FLOOR STAND AND VALVE EXTENSION

WINDOW SCHEDULE										
MARK	QTY	ROUGH OPENING	FRAME MATERIAL	FRAME COLOR	LOCATION	STYLE	WINDOW ELEVATION	WINDOW DETAIL	NOTES	
<b>WATER TREATMENT BUILDING</b>										
A	2	3'-0" X 3'-0"	ALUMINUM	BY OWNER	OFFICE	D. HUNG			EXTERIOR WINDOW WATER TREATMENT BUILDING W/SCREENS	
A	3	3'-0" X 3'-0"	ALUMINUM	BY OWNER	BREAKROOM	D. HUNG			EXTERIOR WINDOW WATER TREATMENT BUILDING W/SCREENS	

DOOR SCHEDULE											
MARK	QTY	SIZE WIDTHXHEIGHT	DOOR MATERIAL	FRAME MATERIAL	FINISH	LOCATION	DOOR ELEVATION	DOOR DETAIL	COLOR	HARDWARE	NOTES
<b>CHEMICAL BUILDING/HSP BUILDING</b>											
C01	2	3'-0" x 7'-0"	FIBERGLASS	FIBERGLASS	BY OWNER	CHEMICAL ROOMS			BY OWNER	E1	EXTERIOR DOOR
<b>WATER TREATMENT BUILDING</b>											
M01	1	14' x 12'	STEEL	STEEL	N/A	WATER TREATMENT BUILDING GARAGE			BY OWNER		ROLLING DOOR
M02	2	3'-0" x 7'-0"	ALUMINUM	ALUMINUM	2'-4" x 3'-0"	GARAGE (2) (EAST WALL)			BY OWNER	E1	EXTERIOR DOOR
M03	1	3'-0" x 7'-0"	ALUMINUM	ALUMINUM	N/A	GARAGE (WEST WALL)			BY OWNER	E1	EXTERIOR DOOR
M04	2	3'-0" x 7'-0"	WOOD	ALUMINUM	2'-4" x 3'-0"	UTILITY ROOM, BREAKROOM			BY OWNER	P1	INTERIOR DOOR
M05	1	3'-0" x 7'-0"	WOOD	ALUMINUM	N/A	BATHROOM			BY OWNER	T1	INTERIOR DOOR W/DOOR VENT
M06	1	3'-0" x 7'-0"	WOOD	ALUMINUM	2'-4" x 3'-0"	OFFICE			BY OWNER	O1	INTERIOR DOOR
M07	1	3'-0" x 7'-0"	ALUMINUM	ALUMINUM	2'-4" x 3'-0"	DOOR TO GARAGE FROM HALL			BY OWNER	E3	INTERIOR DOOR
<b>BOOSTER STATION</b>											
B01	1	(2) 3'-0" x 7'-0"	ALUMINUM	ALUMINUM	N/A	PUMP AREA			BY OWNER	E2	EXTERIOR DOOR

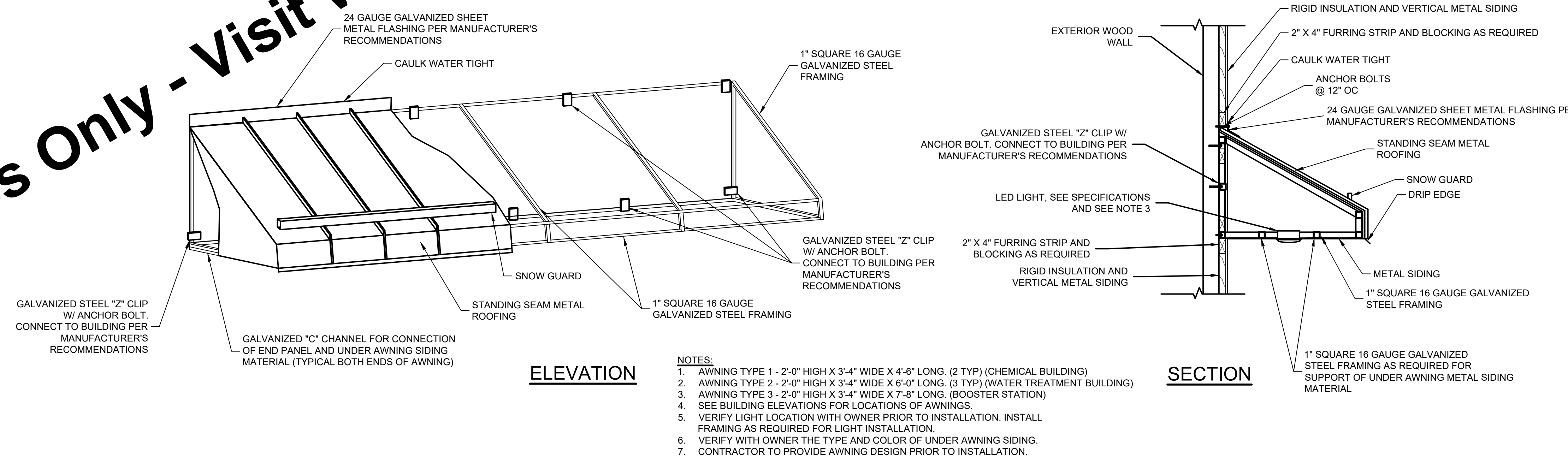

- NOTES:**
- AWNING TYPE 1 - 2'-0" HIGH X 3'-4" WIDE X 4'-6" LONG. (2 TYP) (CHEMICAL BUILDING)
  - AWNING TYPE 2 - 2'-0" HIGH X 3'-4" WIDE X 6'-0" LONG. (3 TYP) (WATER TREATMENT BUILDING)
  - AWNING TYPE 3 - 2'-0" HIGH X 3'-4" WIDE X 7'-8" LONG. (BOOSTER STATION)
  - SEE BUILDING ELEVATIONS FOR LOCATIONS OF AWNINGS.
  - VERIFY LIGHT LOCATION WITH OWNER PRIOR TO INSTALLATION. INSTALL FRAMING AS REQUIRED FOR LIGHT INSTALLATION.
  - VERIFY WITH OWNER THE TYPE AND COLOR OF UNDER AWNING SIDING.
  - CONTRACTOR TO PROVIDE AWNING DESIGN PRIOR TO INSTALLATION.

For Viewing Purposes Only - Visit [www.wesslerengineering.com](http://www.wesslerengineering.com) to Purchase

SCALE VERIFICATION BAR IS ONE INCH LONG ON ORIGINAL DRAWING	DRAWN BY	CLG	NO.	DATE	INITIALS	REVISION DESCRIPTIONS
	CHECKED BY	MAP				
	APPROVED BY	AMS				
	ISSUE DATE	FEBRUARY 2026				
	PROJECT NUMBER	703222-04-001				

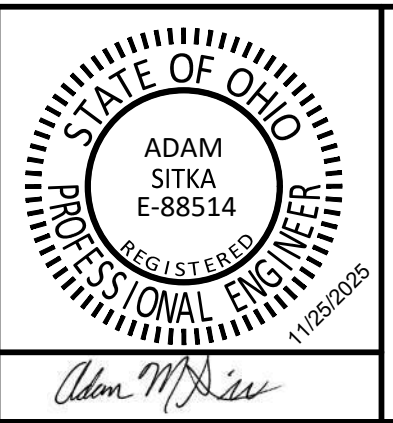

<b>WATER SYSTEM IMPROVEMENTS</b>
CONTRACT B NEW BOOSTER STATION AND WATER TREATMENT PLANT IMPROVEMENTS VILLAGE OF HOLGATE, OHIO
<b>MISCELLANEOUS BUILDING DETAILS</b>

SHEET NO.	7MD4
PAGE NO.	42
DDAGW-4113	



Drawing: X:\Hologic\_Ohio\3222\_Hologic\WTP\Contract B - Booster Station and WTP\DWG\Sheets\703222-04-001.dwg | Layout: 7MD4 | Plotted: 01/22/26 @ 12:12:15 | LasSawaby, CurtisG

SEASONAL SOIL PROTECTION CHART

STABILIZATION PRACTICE	JAN	FEB	MAR	APR	MAY	JUN	JUL	AUG	SEP	OCT	NOV	DEC
PERMANENT SEEDING												
DORMANT SEEDING												
TEMPORARY SEEDING												
SODDING												
MULCHING												

- A. = KENTUCKY BLUEGRASS AND PERENNIAL RYEGRASS 100 LB/ACRE
- B. = KENTUCKY BLUEGRASS AND PERENNIAL RYEGRASS 150 LB/ACRE. PREPARE SEEDBED PRIOR TO NOV 20
- C. = MIX 1 (128 LB/ACRE OATS, 40 LB/ACRE TALL FESCUE, 40 LB/ACRE ANNUAL RYEGRASS), MIX 2 (40 LB/ACRE PERENNIAL RYEGRASS, 40 LB/ACRE TALL FESCUE, 40 LB/ACRE ANNUAL RYEGRASS), MIX 3 (65 LB/ACRE ANNUAL RYEGRASS, 142 LB/ACRE PERENNIAL RYEGRASS, 17 LB/ACRE CREEPING RED FESCUE, 17 LB/ACRE KENTUCKY BLUEGRASS), OR MIX 4 (128 LB/ACRE OATS, 40 LB/ACRE TALL FESCUE, 40 LB/ACRE ANNUAL RYEGRASS)
- D. = MIX 5 (112 LB/ACRE RYE, 40 LB/ACRE TALL FESCUE, 40 LB/ACRE ANNUAL RYEGRASS), MIX 6 (120 LB/ACRE WHEAT, 40 LB/ACRE TALL FESCUE, 40 LB/ACRE ANNUAL RYEGRASS), MIX 7 (40 LB/ACRE PERENNIAL RYE, 40 LB/ACRE TALL FESCUE, 40 LB/ACRE ANNUAL RYEGRASS), OR MIX 8 (40 LB/ACRE ANNUAL RYEGRASS, 40 LB/ACRE PERENNIAL RYEGRASS, 40 LB/ACRE CREEPING RED FESCUE, 40 LB/ACRE KENTUCKY BLUEGRASS)
- E. = SOD
- F. = ANCHORED STRAW/HAY (2 TONS/ACRE) OR WOOD CELLULOSE FIBER (750 LB/ACRE) OR WOOD MULCH/CHIPS (10 TONS/ACRE)

NOTES:

1. IRRIGATION NEEDED DURING MAY THROUGH SEPTEMBER.
2. IRRIGATION NEEDED FOR 2 TO 4 WEEKS AFTER APPLYING SOD.
3. ANCHORED MULCH IS REQUIRED FOR PERMANENT, DORMANT AND TEMPORARY SEEDING.
4. OPTIMUM SEEDING DATES PROVIDED. DATES MAY BE EXTENDED OR SHORTENED BASED ON PROJECT LOCATION.
5. SEED MIXTURES PROVIDED FOR LAWNS AND HIGH MAINTENANCE AREAS.
6. ADDITIONAL REQUIREMENTS AND INFORMATION ARE LOCATED IN THE OHIO DEPT. OF NATURAL RESOURCES RAINWATER AND LAND DEVELOPMENT MANUAL.

MAINTENANCE:

1. INSPECT WITHIN 24 HOURS OF EACH 0.5-INCH RAIN EVENT AND AT LEAST ONCE EVERY 7 CALENDAR DAYS.
2. CHECK FOR EROSION AND MOVEMENT OF MULCH AND REPAIR IMMEDIATELY.
3. MONITOR FOR EROSION DAMAGE AND ADEQUATE COVER (70% DENSITY).
4. RESEED, FERTILIZE OR APPLY MULCH WHERE NECESSARY.

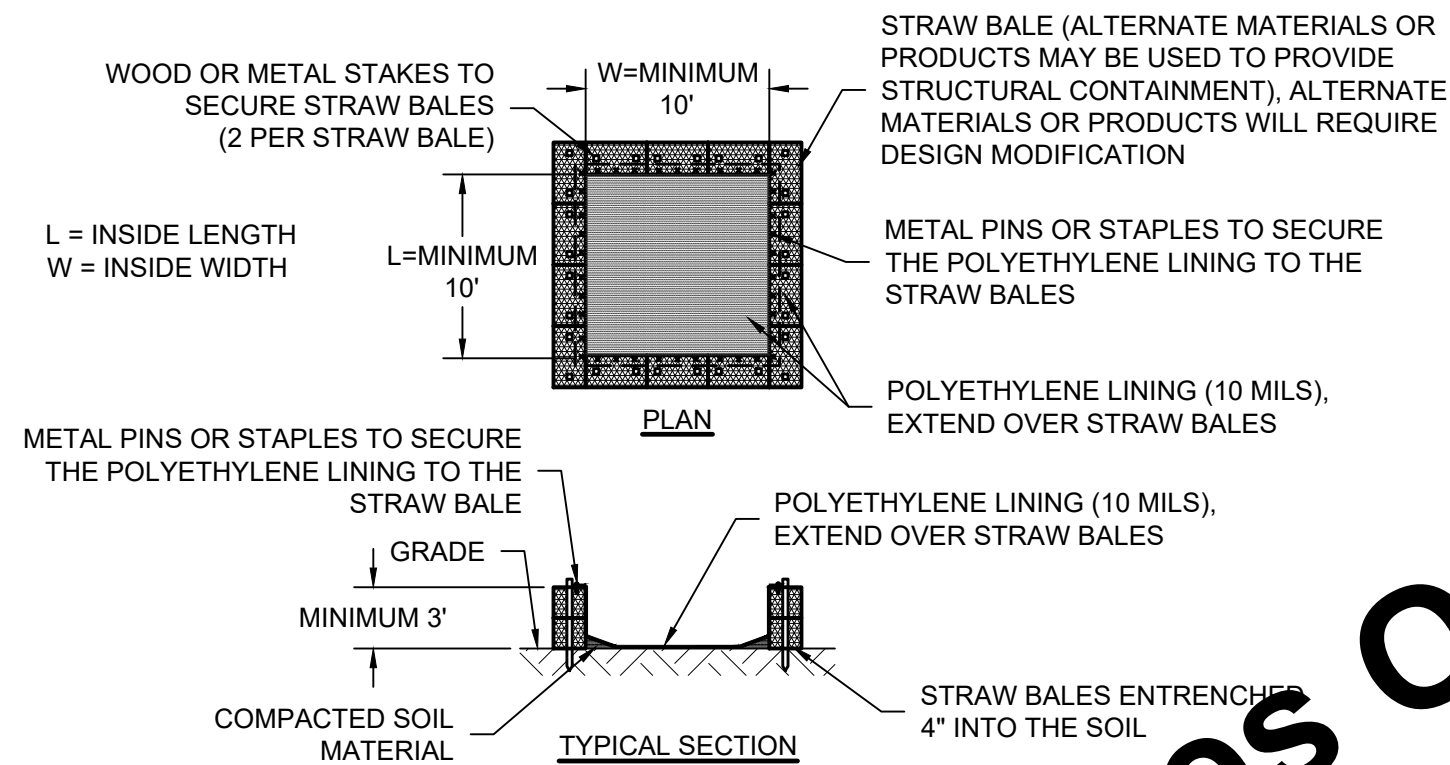

NOTES:

1. LOCATE WASHOUTS AT LEAST 50' FROM ANY CREEKS, WETLANDS, DITCHES, KARST FEATURES, OR STORM DRAIN/CONVEYANCES.

WASHOUT PROCEDURES:

1. DO NOT LEAVE EXCESS MUD IN THE CHUTES OR HOPPER AFTER POURING CONCRETE. MAKE EVERY EFFORT TO EMPTY THE CHUTE AND HOPPER AT THE END OF EACH POUR. REMOVE EXCESS MATERIAL LEFT IN THE CHUTES AND HOPPER, THE QUICKER AND EASIER THE CLEANOUT, THE SMALLER AMOUNTS OF EXCESS CONCRETE (NOT WASHOUT WATER) MAY BE DISPOSED OF IN AREAS THAT WILL NOT FLOW TO AN AREA THAT IS TO BE PROTECTED.
2. SCRAPE AS MUCH MATERIAL FROM THE CHUTES AS POSSIBLE BEFORE WASHING THEM. USE NON-WATER CLEANING METHODS TO MINIMIZE THE AMOUNT OF WASTE TO FLOW OFF SITE.
3. STOP WASHING OUT IN AN AREA THAT CAUSES WATER RUNNING OFF THE DESIGNATED AREA OR IF THE WATER IS NOT BEING CAPTURED WITHIN THE WASHOUT AREA.
4. DO NOT BACK FLUSH INTO THE WASHOUT AREA.
5. DO NOT USE ADDITIONAL WASH WATER.
6. DO NOT WASH OR DRAIN WASTE WATERS TO STORM DRAINS, WETLANDS, STREAMS, RIVERS, CREEKS, DITCHES, OR STREETS.

MAINTENANCE:

1. MAINTENANCE REQUIREMENTS PROVIDED IN SPECIFICATIONS.

CONCRETE WASHOUT

SCALE: NONE

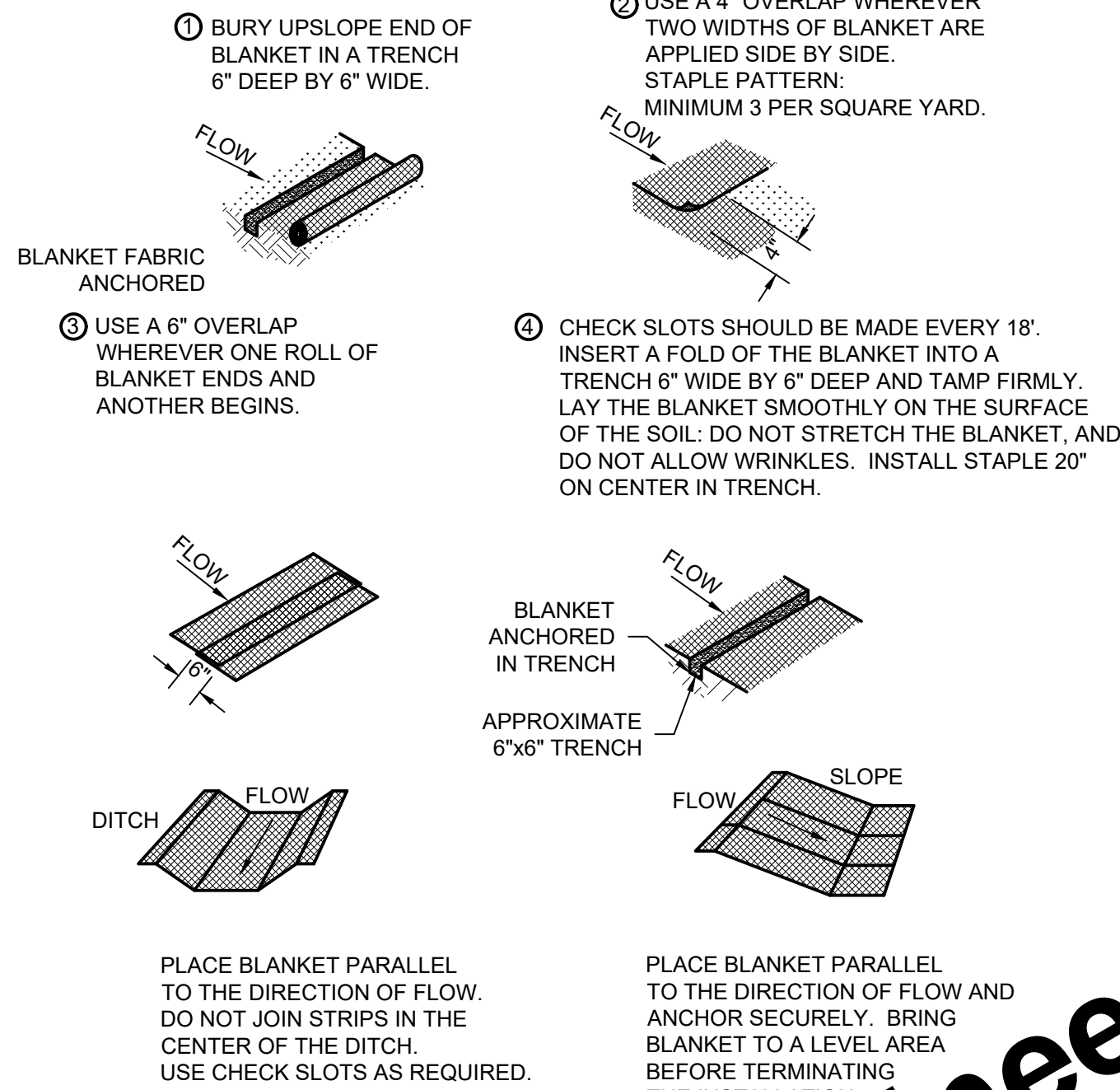

PRODUCT:

1. NORTH AMERICAN GREEN SC150, OR EQUAL.

NOTES:

1. PROTECT THE SLOPES WITH AN EROSION CONTROL BLANKET IMMEDIATELY AFTER CONSTRUCTION DISTURBS SLOPES EQUAL OR STEEPER THAN 3:1.

MAINTENANCE:

1. INSPECT FOR EROSION AFTER EACH TOPOGRAPHIC SURVEY DURING VEGETATION ESTABLISHMENT, AND AT LEAST ONCE EVERY 7 CALENDAR DAYS.
2. IF ANY AREAS SHOW EROSION, REPAIR THAT PORTION OF THE BLANKET, ADD SOIL, RESEED, RELAY AND STAPLE BLANKET.
3. CHECK AREAS PERIODICALLY FOR VEGETATION ESTABLISHMENT.

EROSION CONTROL BLANKET

SCALE: NONE

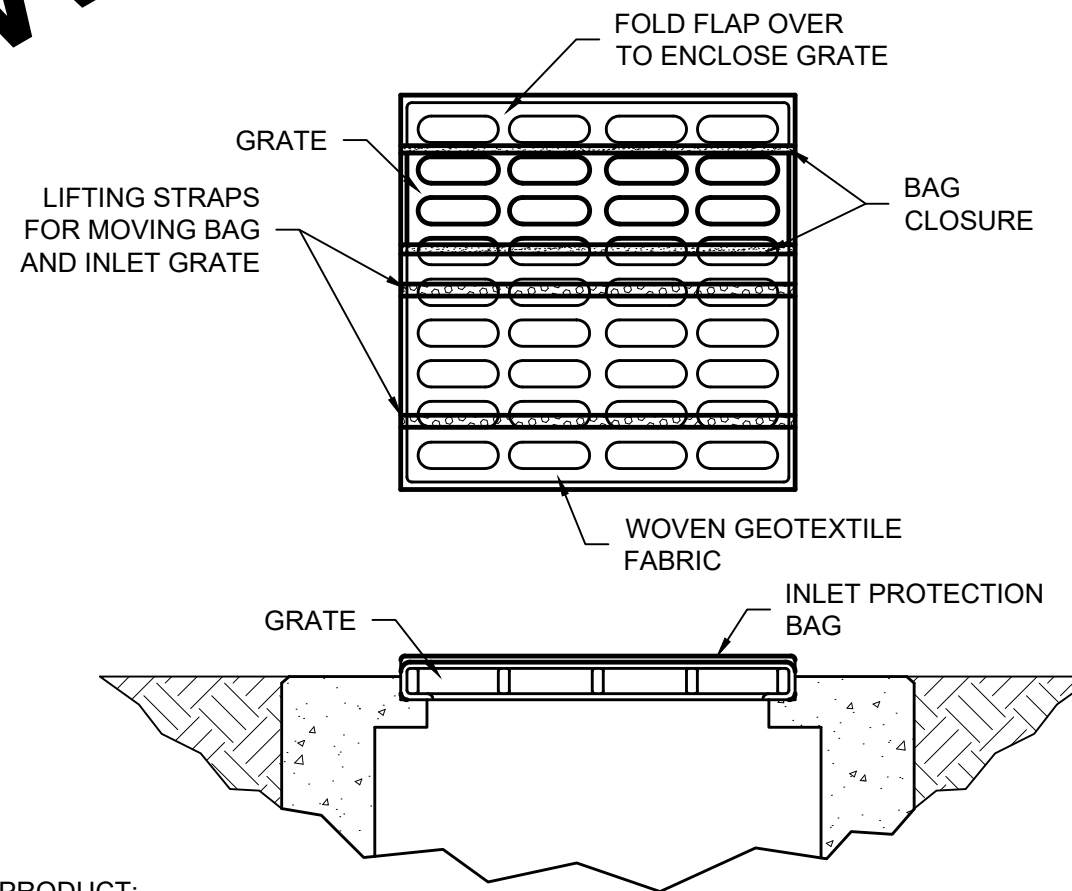

PRODUCT:

1. DANDY BAG, OR APPROVED EQUAL.

INSTALLATION:

1. THE EMPTY INLET PROTECTION BAG SHOULD BE PLACED OVER THE GRATE AS THE GRATE STANDS ON END.
2. TUCK THE ENCLOSURE FLAP INSIDE TO COMPLETELY ENCLOSE THE GRATE.
3. HOLDING THE LIFTING DEVICES (DO NOT RELY ON LIFTING DEVICES TO SUPPORT THE ENTIRE WEIGHT OF THE GRATE), PLACE THE GRATE INTO ITS FRAME.

MAINTENANCE:

1. REMOVE ALL ACCUMULATED SEDIMENT AND DEBRIS FROM SURFACE AND VICINITY OF UNIT AFTER EACH STORM EVENT.
2. REMOVE SEDIMENT THAT HAS ACCUMULATED WITHIN THE CONTAINMENT AREA OF THE INLET PROTECTION BAG AS NEEDED.
3. INSPECT WITHIN 24 HOURS OF A RAIN EVENT AND ONCE EVERY 7 CALENDAR DAYS.

INLET PROTECTION BAG

SCALE: NONE

EROSION CONTROL SCHEDULE

CONSTRUCTION ACTIVITY	SCHEDULE CONSIDERATION
REVIEW THE EROSION CONTROL SCHEDULE IN THE STORMWATER POLLUTION PREVENTION PLAN (SWPPP) AND REVISE AS NEEDED TO PHASE CONSTRUCTION ACTIVITIES TO MINIMIZE THE FOOTPRINT OF DISTURBED UNSTABLE AREAS. SUBMIT A REVISED EROSION CONTROL SCHEDULE AS NEEDED FOR TEMPORARY AND PERMANENT EROSION CONTROL WORK AS APPLICABLE.	COMPLETE BEFORE CONSTRUCTION BEGINS.
CONSTRUCTION ACCESS - ENTRANCE TO SITE, CONSTRUCTION ROUTES, AREAS DESIGNATED FOR EQUIPMENT PARKING OR MATERIAL STAGING AND WASTE HANDLING.	THIS IS THE FIRST LAND-DISTURBING ACTIVITY. AS SOON AS CONSTRUCTION BEGINS, STABILIZE ANY BARE AREAS WITH AGGREGATE AND TEMPORARY VEGETATION.
SEDIMENT TRAPS AND BARRIERS - BASIN TRAPS, SILT FENCE AND PERIMETER PROTECTION.	AFTER CONSTRUCTION IS COMPLETED, BASINS SHALL BE INSTALLED IMMEDIATELY. IN THE ADDITION OF MORE TRAPS AND BARRIERS AS NEEDED DURING GRADING. SET UP PERIMETER OR NATURAL FEATURES, TREES AND BARRIERS. ALL SEDIMENT AND EROSION CONTROLS SHOULD BE INSTALLED AND FUNCTIONAL WITHIN 7 DAYS OF THE START OF GRUBBING ACTIVITY ON-SITE.
RUNOFF CONTROL - DIVERSIONS, PERIMETER PROTECTION, CHECK DAMS, OUTLET PROTECTION.	RUNOFF CONTROL PRACTICES SHALL BE INSTALLED AFTER THE INSTALLATION OF SEDIMENT TRAPS AND BEFORE LAND GRADING. ADDITIONAL RUNOFF CONTROL MEASURES MAY BE INSTALLED DURING GRADING. AREAS WITHIN 50 FEET OF SURFACE WATERS OF THE STATE ARE REQUIRED TO BE STABILIZED WITHIN 2 DAYS.
RUNOFF CONVEYANCE SYSTEM - STABILIZE STREAM BANKS, STORM DRAINS, CHANNELS, INLET AND OUTLET PROTECTION, SLOPE DRAINS.	AS NECESSARY, STABILIZE STREAM BANKS AND SIDE SLOPES OF RUNOFF SYSTEMS AS SOON AS POSSIBLE. USE EROSION CONTROL BLANKETS OR SLOPE DRAINS TO PREVENT EROSION. INSTALL INLET PROTECTION TO PREVENT SEDIMENTS FROM ENTERING STORM DRAINAGE SYSTEMS. PROTECT STORM OUTLETS TO PREVENT EROSION.
LAND CLEARING AND GRADING - SITE PREPARATION (CUTTING, FILLING, AND GRADING, SEDIMENT TRAPS, BARRIERS, DIVERSIONS, DRAINS, SURFACE ROUGHENING).	IMPLEMENT CLEARING AND GRADING AFTER INSTALLATION OF SEDIMENT TRAPS AND RUNOFF CONTROL MEASURES, AND INSTALL ADDITIONAL CONTROL MEASURES AS GRADING CONTINUES. CLEAR BORROW AND DISPOSAL AREAS AS NEEDED.
SURFACE STABILIZATION - TEMPORARY AND PERMANENT SEEDING, MULCHING, SODDING, RIPRAP, EROSION CONTROL BLANKET.	APPLY TEMPORARY OR PERMANENT STABILIZING MEASURES IMMEDIATELY TO ANY DISTURBED AREAS WHERE WORK HAS BEEN EITHER COMPLETED OR DELAYED.
CONSTRUCTION - STRUCTURES, UTILITIES, PAVING, CONCRETE WASHOUT, AND CONSTRUCTION ENTRANCES.	DURING CONSTRUCTION, INSTALL ANY EROSION AND SEDIMENTATION CONTROL MEASURES THAT ARE NEEDED.
LANDSCAPING AND FINAL STABILIZATION - TOPSOILING, TREES AND SHRUBS, PERMANENT SEEDING, MULCHING, SODDING, RIPRAP.	THIS IS THE LAST CONSTRUCTION PHASE. STABILIZE ALL DISTURBED AREAS, INCLUDING BORROW AND SPOIL AREAS, AND REMOVE ALL TEMPORARY CONTROL MEASURES. FINAL STABILIZATION IS WHEN A UNIFORM DENSITY OF 70% VEGETATION COVER IS MET. PROVIDE NOTIFICATION TO THE OWNER WHEN THE ENTIRE SITE HAS BEEN STABILIZED AND ALL CONSTRUCTION MATERIALS, WASTES, AND EQUIPMENT HAVE BEEN REMOVED.

EROSION CONTROL SCHEDULE

SCALE: NONE

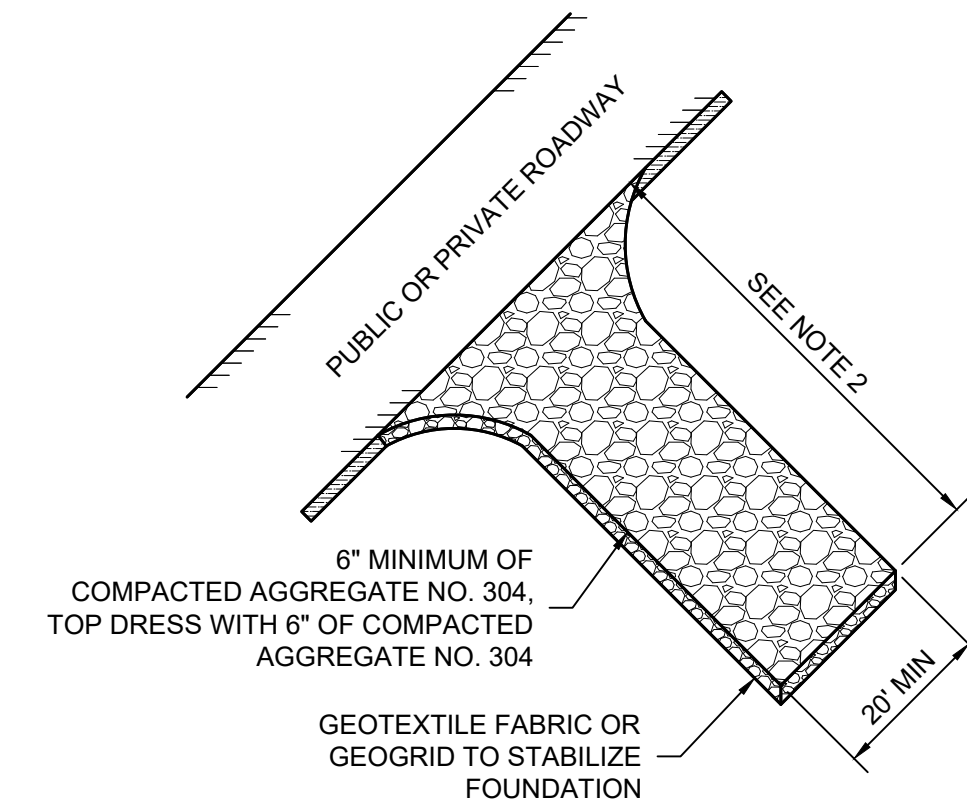

NOTES:

1. PLACE CONSTRUCTION ENTRANCE AS SHOWN ON THE PLANS AND AT ALL TEMPORARY CONSTRUCTION DRIVES THAT ARE INSTALLED.
2. FOR LARGE SITES (2 ACRES OR LARGER) THE MINIMUM LENGTH IS 150'. FOR SMALLER SITES (LESS THAN 2 ACRES) THE MINIMUM LENGTH IS 70'.
3. PROVIDE CULVERT OR OTHER METHODS AS NECESSARY TO MAINTAIN POSITIVE DRAINAGE.

MAINTENANCE:

1. INSPECT DAILY AND REPLACE DISPLACED STONE.
2. IMMEDIATELY REMOVE MUD AND SEDIMENT TRACKED ONTO ADJACENT ROADWAY.
3. RESHAPE PAD AS NEEDED FOR DRAINAGE AND RUNOFF CONTROL.
4. AT COMPLETION OF PROJECT COMPLETELY REMOVE AND RESTORE SITE TO ORIGINAL CONDITIONS, OR AS APPLICABLE USE FOR BASE OF NEW PERMANENT DRIVE, MAINTAINING DESIGN ELEVATIONS AND SECTION.

CONSTRUCTION ENTRANCE

SCALE: NONE

WATER SYSTEM IMPROVEMENTS

CONTRACT B NEW BOOSTER STATION AND WATER TREATMENT PLANT IMPROVEMENTS  
VILLAGE OF HOLGATE, OHIO

EROSION CONTROL DETAILS

SHEET NO.

7EC1

PAGE NO.

43

DDAGW-4113

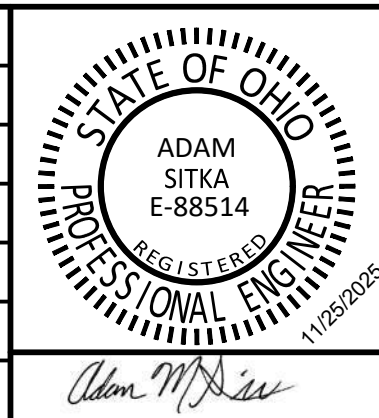

02/27/2020

For Viewing Purposes Only - Visit www.wesslerengineering.com to purchase

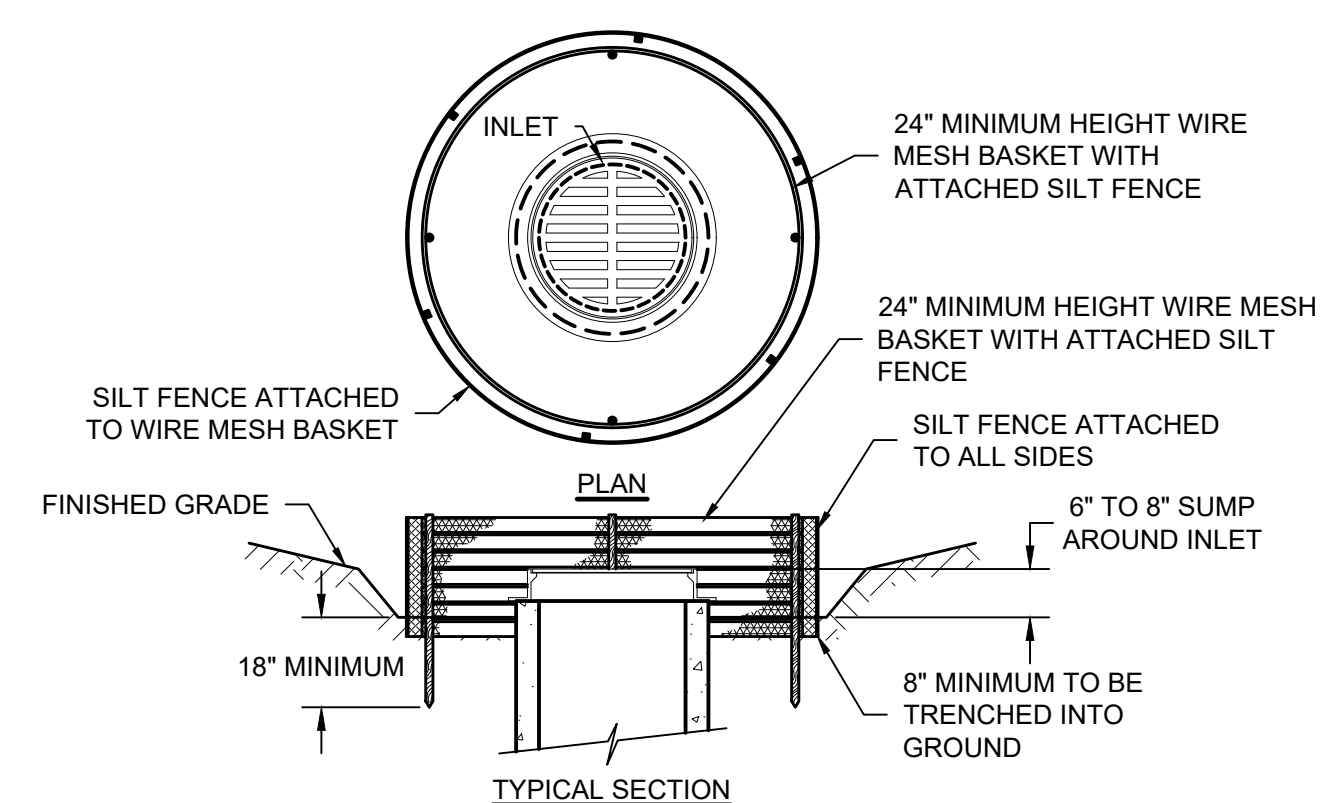
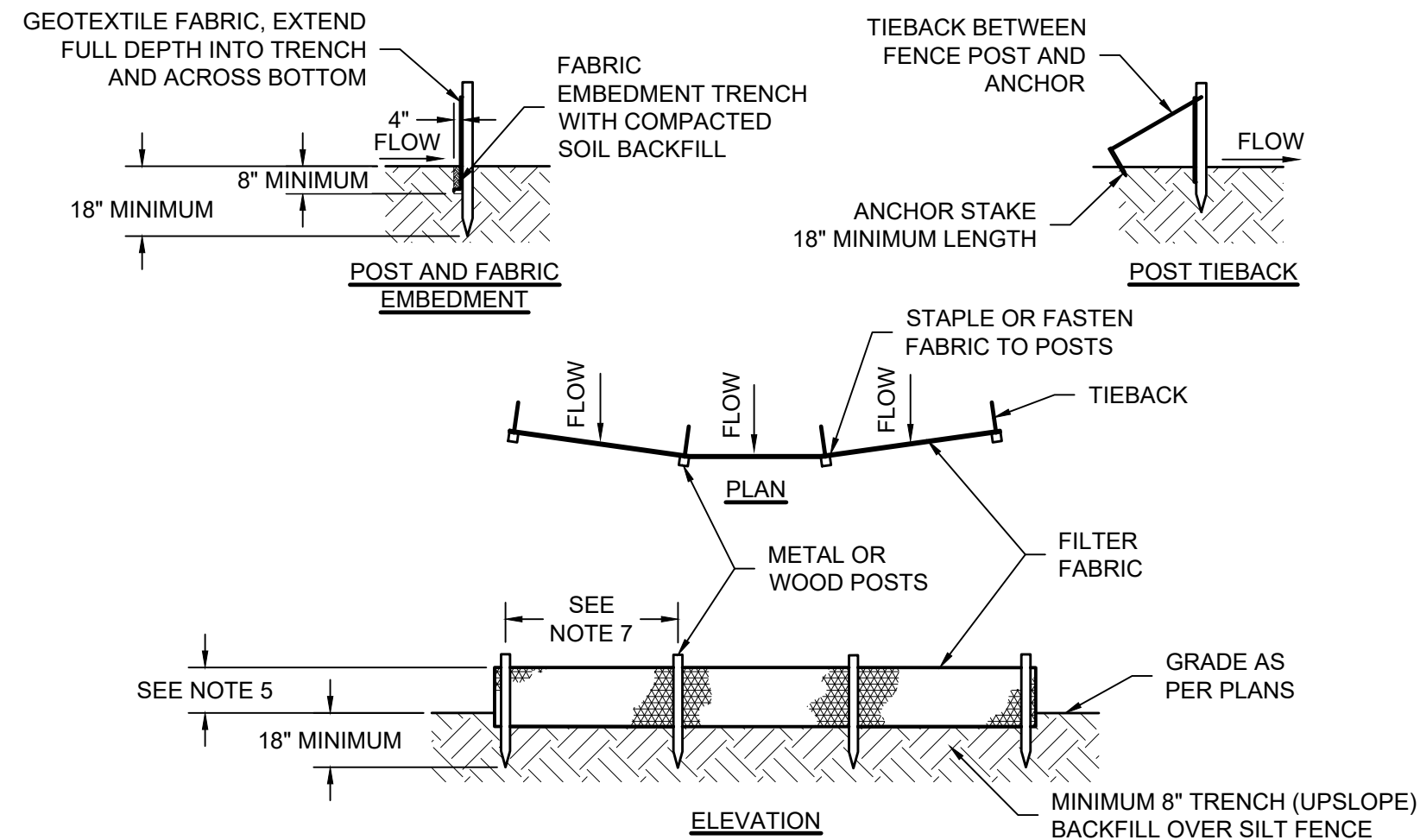

- NOTES:**
1. SYNTHETIC FILTER FABRIC SHALL BE A PERVIOUS SHEET OF WOVEN OR NON-WOVEN GEOTEXTILE FABRIC AND SHALL BE CERTIFIED BY THE MANUFACTURER OR SUPPLIER AS CONFORMING TO THE FOLLOWING REQUIREMENTS:
    - a. TEXTILE STRENGTH AT 20% (MAXIMUM) ELONGATION, PER ASTM D4632.
    - b. WOVEN EXTRA STRENGTH - 50 LB/LINEAR INCH (MINIMUM), NON-WOVEN EXTRA STRENGTH - 70 LB/INCH (MINIMUM).
    - c. WOVEN STANDARD STRENGTH - 30 LB/LINEAR INCH (MINIMUM), NON-WOVEN STANDARD STRENGTH - 50 LB/INCH (MINIMUM).
    - d. APPARENT OPENING SIZE (AOS) (U.S. SIEVE) - NO. 30 PARTICLE SIZE OF 0.6 mm (MAXIMUM), ASTM D4751.
    - e. PERMITTIVITY - 0.05 S<sup>1</sup> (MAXIMUM), ASTM D4491.
  2. POSTS FOR SILT FENCES SHALL BE EITHER 2"x2" SQUARE WOOD OR EQUIVALENT METAL POSTS WITH A MINIMUM LENGTH OF 5'. METAL POSTS SHALL HAVE PROJECTIONS FOR FASTENING WIRE TO THEM.
  3. ANCHOR STAKES FOR SILT FENCES SHALL BE 1"x2" WOOD (PREFERRED) OR EQUIVALENT METAL WITH A MINIMUM LENGTH OF 18".
  4. WIRE FENCE REINFORCEMENT FOR SILT FENCES USING STANDARD STRENGTH FILTER CLOTH SHALL BE A MINIMUM OF 42" IN HEIGHT, A MINIMUM OF 14 GAUGE, AND SHALL HAVE A MAXIMUM MESH SPACING OF 6".
  5. THE HEIGHT OF THE BARRIER SHALL BE A MINIMUM OF 18" AND A MAXIMUM OF 30".
  6. THE FABRIC SHALL BE PURCHASED IN A CONTINUOUS ROLL CUT TO THE LENGTH OF THE BARRIER TO AVOID THE USE OF JOINTS. WHEN JOINTS ARE NECESSARY, FILTER FABRIC SHALL BE SPICED TOGETHER ONLY AT A SUPPORT POST, WITH A MINIMUM 6" OVERLAP, AND SECURELY SEALED.
  7. POSTS SHALL BE SPACED A MAXIMUM OF 6' APART AT THE BARRIER LOCATION AND DRIVEN SECURELY INTO THE GROUND (MINIMUM OF 18"). WHEN STANDARD STRENGTH FABRIC IS USED WITH THE WIRE SUPPORT FENCE, POST SPACING SHALL NOT EXCEED 8".
  8. THE SPACING OF TIEBACKS SHALL EQUAL THE SPACING OF THE POSTS. ADDITIONAL POST DEPTH OR TIEBACKS MAY BE REQUIRED IN UNSTABLE SOILS.
  9. A TRENCH SHALL BE EXCAVATED APPROXIMATELY 4" WIDE AND A MINIMUM OF 8" DEEP ALONG THE LINE OF POSTS AND UPSLOPE FROM THE BARRIER.
  10. WHEN STANDARD STRENGTH FILTER FABRIC IS USED WITH A WIRE MESH SUPPORT FENCE IT SHALL BE FASTENED SECURELY TO THE UPSLOPE SIDE OF THE POSTS USING HEAVY DUTY 1" WIRE STAPLES, TIE WIRES OR HOG RINGS. THE WIRE SHALL EXTEND INTO THE TRENCH A MINIMUM OF 2" AND SHALL NOT EXTEND MORE THAN 36" ABOVE THE ORIGINAL GROUND SURFACE.
  11. THE STANDARD STRENGTH FILTER FABRIC, WITHOUT A WIRE MESH SUPPORT FENCE, SHALL BE STAPLED OR WIRED TO THE FENCE, AND A MINIMUM 8" OF THE FABRIC SHALL BE EXTENDED INTO THE TRENCH. THE FABRIC SHALL NOT EXTEND MORE THAN 36" ABOVE THE ORIGINAL GROUND SURFACE. DO NOT STAPLE FILTER FABRIC TO EXISTING TREES.
  12. WHEN EXTRA STRENGTH FILTER FABRIC OR BURLAP AND POST SPACING IS LESS THAN THE MAXIMUM SPECIFIED SPACING OF 6", THE WIRE MESH SUPPORT FENCE MAY BE ELIMINATED.
  13. BACKFILL THE TRENCH AND COMPACT THE SOIL OVER THE FILTER FABRIC.
  14. REMOVE SILT FENCES WHEN THEY HAVE SERVED THEIR USEFUL PURPOSE, BUT NOT BEFORE THE UPSLOPE AREA HAS BEEN PERMANENTLY STABILIZED.
  15. SILT FENCE SHALL NOT BE USED AS A DIVERSION AND SHALL NOT BE INSTALLED ACROSS A STREAM, CHANNEL, DITCH, SWALE, ETC.

- NOTES:**
1. SYNTHETIC FILTER FABRIC SHALL BE A PERVIOUS SHEET OF WOVEN OR NON-WOVEN GEOTEXTILE FABRIC AND SHALL BE CERTIFIED BY THE MANUFACTURER OR SUPPLIER AS CONFORMING TO THE FOLLOWING REQUIREMENTS:
    - a. TEXTILE STRENGTH AT 20% (MAXIMUM) ELONGATION, PER ASTM D4632.
    - b. WOVEN EXTRA STRENGTH - 50 LB/LIN IN. (MINIMUM), NON-WOVEN EXTRA STRENGTH - 70 LB/IN. (MINIMUM).
    - c. WOVEN STANDARD STRENGTH - 30 LB/LIN IN. (MINIMUM), NON-WOVEN STANDARD STRENGTH - 50 LB/IN. (MINIMUM).
    - d. APPARENT OPENING SIZE (AOS) (U.S. SIEVE) - NO. 30 PARTICLE SIZE OF 0.6 mm (MAXIMUM), PER ASTM D4751.
    - e. PERMITTIVITY - 0.05 S<sup>1</sup> (MAXIMUM), PER ASTM D4491.
  2. WHEN STANDARD STRENGTH FILTER FABRIC IS USED WITH A WIRE MESH SUPPORT FENCE FASTEN THE FABRIC SECURELY TO THE UPSLOPE SIDE OF THE POSTS USING HEAVY DUTY 1" WIRE STAPLES, TIE WIRES OR HOG RINGS. THE WIRE SHALL EXTEND INTO THE TRENCH A MINIMUM OF 2" AND SHALL NOT EXTEND MORE THAN 36" ABOVE THE ORIGINAL GROUND SURFACE.
- MAINTENANCE:**
1. INSPECT WITHIN 24 HOURS OF A RAIN EVENT AND DAILY DURING PROLONGED RAINFALL. INSPECT AT LEAST ONCE EVERY 7 CALENDAR DAYS.
  2. REPLACE THE FABRIC PROMPTLY IF THE FABRIC DECOMPOSES OR BECOMES INEFFECTIVE. IMMEDIATELY MAKE ANY REQUIRED REPAIRS.
  3. REMOVE SEDIMENT DEPOSITS FROM THE BARRIER AFTER EACH STORM EVENT AND WHEN IT REACHES HALF THE HEIGHT OF THE BARRIER.
  4. SPREAD ANY SEDIMENT DEPOSITS REMAINING IN PLACE AFTER THE SILT FENCE IS NO LONGER REQUIRED, AND DRESS TO CONFORM WITH THE FINISHED GRADING.

**SILT FENCE**  
SCALE: NONE

**SILT FENCE INLET SEDIMENT BARRIER**  
SCALE: NONE

For Viewing Purposes Only - Visit [www.wesslerengineering.com](http://www.wesslerengineering.com) to Purchase

Drawing: X:\Hogdale\_OH\703222\_Hogdale WTP\Contract B - Booster Station and WTP\DWG\Sheets\703222-EC.dwg | Layout: TEC2 | Plotter: TEC2 | Plotter: 01/21/26 @ 03:07:39 | LaseSweetBy: CuisiG

SCALE VERIFICATION	DRAWN BY	CLG	NO.	DATE	INITIALS	REVISION DESCRIPTIONS
BAR IS ONE INCH LONG ON ORIGINAL DRAWING	CHECKED BY	MAP				
	APPROVED BY	AMS				
	ISSUE DATE	FEBRUARY 2026				
	PROJECT NUMBER	703222-04-001				

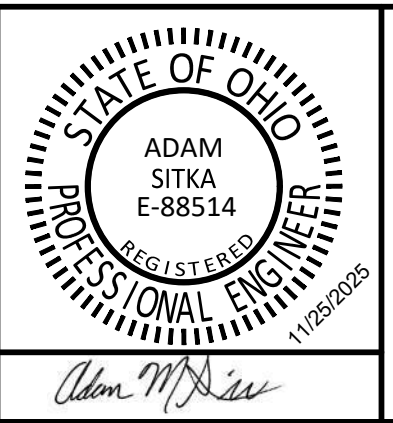

<b>WATER SYSTEM IMPROVEMENTS</b>
CONTRACT B NEW BOOSTER STATION AND WATER TREATMENT PLANT IMPROVEMENTS VILLAGE OF HOGDALE, OHIO
<b>EROSION CONTROL DETAILS</b>

SHEET NO. <b>7EC2</b>
PAGE NO. <b>44</b>
DDAGW-4113

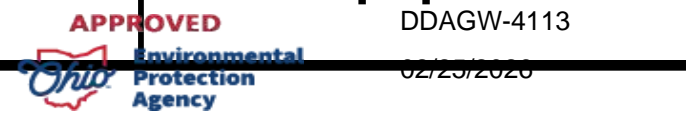

ADDITIONAL ENVIRONMENTAL NOTES

1. FOR SAFETY MEASURES, REFER TO THE FOLLOWING SECTION(S) OF THE SPECIFICATIONS

- SECTION 02050 3.02:  
\*PROTECTION
- ACCESS: PROVIDE SAFE ACCESS TO, AND EGRESS FROM, ALL WORKING AREAS AT ALL TIMES DURING THE DEMOLITION. PROVIDE ADEQUATE PROTECTION OF ACCESS AND EGRESS AREAS FROM FALLING MATERIALS.
  - GENERAL SAFETY: PROVIDE WARNING SIGNS, PROTECTIVE BARRIERS, AND WARNING LIGHTS ADJACENT TO THE WORK TO PROTECT CONSTRUCTION PERSONNEL AND THE PUBLIC. MAINTAIN THESE ITEMS DURING THE DEMOLITION PERIOD.
  - EXISTING SERVICES: DO NOT BEGIN THE DEMOLITION WORK UNTIL ALL MECHANICAL AND ELECTRICAL SERVICES AFFECTED BY THE WORK HAVE BEEN PROPERLY DISCONNECTED. REROUTE OR RECONNECT INTERCONNECTING PIPING AND ELECTRICAL SERVICES THAT ARE TO REMAIN IN SERVICE EITHER PERMANENTLY OR TEMPORARILY IN A MANNER THAT WILL NOT INTERFERE WITH THE OPERATION OF THE REMAINING FACILITIES.
  - HAZARDS: PERFORM TESTING AND AIR PURGING WHERE THE PRESENCE OF HAZARDOUS CHEMICALS, GASES, FLAMMABLE MATERIALS, OR OTHER DANGEROUS SUBSTANCES ARE APPARENT OR SUSPECTED AND ELIMINATE THE HAZARD BEFORE DEMOLITION IS STARTED.
  - PROVIDE ADEQUATE SCAFFOLDING, SHORING, BRACING, RAILINGS, TOE BOARDS AND PROTECTIVE COVERINGS DURING DEMOLITION TO PROTECT PERSONNEL AND EQUIPMENT AGAINST INJURY OR DAMAGE.
  - COVER FLOOR OPENINGS NOT USED FOR MATERIAL DROPS WITH MATERIAL SUBSTANTIAL ENOUGH TO SUPPORT LOADS PLACED ON THEM. PROPERLY SECURE THE COVERS TO PREVENT ACCIDENTAL MOVEMENT.
  - ALWAYS PROVIDE ADEQUATE LIGHTING DURING DEMOLITION.
  - CLOSE OFF AREAS BELOW DEMOLITION WORK WHILE THE DEMOLITION WORK IS BEING PERFORMED.
  - CAREFULLY PROTECT ALL MECHANICAL AND ELECTRICAL EQUIPMENT FROM THE DEPOSIT AND ACCUMULATION OF DUST AND DEBRIS.\*

2. FOR SAFETY AND PROTECTION, REFER TO THE FOLLOWING SECTION(S) OF THE SPECIFICATIONS

- SECTION 00510 7.12
- CONTRACTOR SHALL BE SOLELY RESPONSIBLE FOR INITIATING, MAINTAINING, AND SUPERVISING ALL SAFETY PRECAUTIONS AND PROGRAMS IN CONNECTION WITH THE WORK. SUCH RESPONSIBILITY DOES NOT RELIEVE SUBCONTRACTORS OF THEIR RESPONSIBILITY FOR THE SAFETY OF PERSONS OR PROPERTY IN THE PERFORMANCE OF THEIR WORK, NOR FOR COMPLIANCE WITH APPLICABLE SAFETY LAWS AND REGULATIONS. CONTRACTOR SHALL TAKE ALL NECESSARY PRECAUTIONS FOR THE SAFETY OF, AND SHALL PROVIDE THE NECESSARY PROTECTION TO PREVENT DAMAGE, INJURY, OR LOSS TO:
    - ALL PERSONS ON THE SITE OR WHO MAY BE AFFECTED BY THE WORK;
    - ALL THE WORK AND MATERIALS AND EQUIPMENT TO BE INCORPORATED THEREIN, WHETHER IN
    - STORAGE ON OR OFF THE SITE; AND
    - OTHER PROPERTY AT THE SITE OR ADJACENT THERETO, INCLUDING TREES, SHRUBS, LAWNS, WALKS, PAVEMENTS, ROADWAYS, STRUCTURES, OTHER WORK IN PROGRESS, UTILITIES, AND UNDERGROUND FACILITIES NOT DESIGNATED FOR REMOVAL, RELOCATION, OR REPLACEMENT IN THE COURSE OF CONSTRUCTION.
  - CONTRACTOR SHALL COMPLY WITH ALL APPLICABLE LAWS AND REGULATIONS RELATING TO THE SAFETY OF PERSONS OR PROPERTY, OR TO THE PROTECTION OF PERSONS OR PROPERTY FROM DAMAGE, INJURY, OR LOSS; AND SHALL ERECT AND MAINTAIN ALL NECESSARY SAFEGUARDS FOR SUCH SAFETY AND PROTECTION. CONTRACTOR SHALL NOTIFY OWNER; THE OWNERS OF ADJACENT PROPERTY, UNDERGROUND FACILITIES, AND OTHER UTILITIES; AND OTHER CONTRACTORS AND UTILITY OWNERS PERFORMING WORK AT OR ADJACENT TO THE SITE, WHEN PROSECUTION OF THE WORK MAY AFFECT THEM, AND SHALL COOPERATE WITH THEM IN THE PROTECTION, REMOVAL, RELOCATION, AND REPLACEMENT OF THEIR PROPERTY OR WORK IN PROGRESS.
  - CONTRACTOR SHALL COMPLY WITH THE APPLICABLE REQUIREMENTS OF OWNER'S SAFETY PROGRAMS, IF ANY. THE SUPPLEMENTARY CONDITIONS IDENTIFY ANY OWNER'S SAFETY PROGRAMS THAT ARE APPLICABLE TO THE WORK.
  - CONTRACTOR SHALL INFORM OWNER AND ENGINEER OF THE SPECIFIC REQUIREMENTS OF CONTRACTOR'S SAFETY PROGRAM WITH WHICH OWNER'S AND ENGINEER'S EMPLOYEES AND REPRESENTATIVES MUST COMPLY WHILE AT THE SITE.
  - ALL DAMAGE, INJURY, OR LOSS TO ANY PROPERTY REFERRED TO IN PARAGRAPH 7.12.A.2 OR 7.12.A.3 CAUSED, DIRECTLY OR INDIRECTLY, IN WHOLE OR IN PART, BY CONTRACTOR, ANY SUBCONTRACTOR, SUPPLIER, OR ANY OTHER INDIVIDUAL OR ENTITY DIRECTLY OR INDIRECTLY EMPLOYED BY ANY OF THEM TO PERFORM ANY OF THE WORK, OR ANYONE FOR WHOSE ACTS ANY OF THEM MAY BE LIABLE, SHALL BE REMEDIED BY CONTRACTOR AT ITS EXPENSE (EXCEPT DAMAGE OR LOSS ATTRIBUTABLE TO THE FAULT OF DRAWINGS OR SPECIFICATIONS OR TO THE ACTS OR OMISSIONS OF OWNER OR ENGINEER OR ANYONE EMPLOYED BY ANY OF THEM, OR ANYONE FOR WHOSE ACTS ANY OF THEM MAY BE LIABLE, AND NOT ATTRIBUTABLE, DIRECTLY OR INDIRECTLY, IN WHOLE OR IN PART, TO THE FAULT OR NEGLIGENCE OF CONTRACTOR OR ANY SUBCONTRACTOR, SUPPLIER, OR OTHER INDIVIDUAL OR ENTITY DIRECTLY OR INDIRECTLY EMPLOYED BY ANY OF THEM).
  - CONTRACTOR'S DUTIES AND RESPONSIBILITIES FOR SAFETY AND PROTECTION SHALL CONTINUE UNTIL SUCH TIME AS ALL THE WORK IS COMPLETED AND ENGINEER HAS ISSUED A NOTICE TO OWNER AND CONTRACTOR IN ACCORDANCE WITH PARAGRAPH 15.06.B THAT THE WORK IS ACCEPTABLE (EXCEPT AS OTHERWISE EXPRESSLY PROVIDED IN CONNECTION WITH SUBSTANTIAL COMPLETION).
  - CONTRACTOR'S DUTIES AND RESPONSIBILITIES FOR SAFETY AND PROTECTION SHALL RESUME WHENEVER CONTRACTOR OR ANY SUBCONTRACTOR OR SUPPLIER RETURNS TO THE SITE TO FULFILL WARRANTY OR CORRECTION OBLIGATIONS, OR TO CONDUCT OTHER TASKS ARISING FROM THE CONTRACT DOCUMENTS.\*

3. FOR TRAFFIC CONTROL, REFER TO THE FOLLOWING SECTION(S) OF THE SPECIFICATIONS

- SECTION 01500 2.01 (H):
- CONSTRUCTION SIGNS AND EQUIPMENT
    - PROVIDE AND ERECT CONSTRUCTION SIGNS, LIGHTS, CHANNELIZING DEVICES, AND OTHER TRAFFIC CONTROL EQUIPMENT IN ACCORDANCE WITH THE MUTCD AND THE OHIO SUPPLEMENT REQUIREMENTS.
    - PROVIDE, ERECT, AND MAINTAIN CONSTRUCTION SIGNS PER THE CURRENT REQUIREMENTS OF THE FUNDS AGENCY.\*

SECTION 01500 3.04 (A-C):

- \*3.04 MAINTENANCE OF TRAFFIC
- GENERAL
    - COMPLY WITH THE REQUIREMENTS OF THE STATE, CITY OR COUNTY HIGHWAY, AND STREET DEPARTMENTS FOR ALL TRAFFIC MAINTENANCE.
    - MAINTAIN ALL CONSTRUCTION SIGNS, LIGHTS, CHANNELIZING DEVICES, AND OTHER TRAFFIC CONTROL EQUIPMENT IN PROPER WORKING ORDER.
    - DURING CONSTRUCTION, MAINTAIN AND PROTECT THE PEDESTRIAN AND VEHICULAR TRAFFIC AT ALL TIMES ON ALL STREETS INVOLVED AND PROVIDE ACCESS TO ALL RESIDENTIAL AND COMMERCIAL ESTABLISHMENTS ADJACENT TO THE CONSTRUCTION AREA.
  - NOTIFICATION REQUIREMENTS
    - BEFORE CLOSING ANY THOROUGHFARE, NOTIFY AND, IF NECESSARY, OBTAIN A PERMIT OR PERMITS FROM THE DULY CONSTITUTED PUBLIC AUTHORITY HAVING JURISDICTION (STATE, COUNTY, OR CITY).
    - NOTIFY THE ENGINEER OF ANY CLOSED ROAD OR DRIVE CLOSURES 72 HOURS IN ADVANCE OF THE PROPOSED CLOSING. PLACE ALL PROPER TRAFFIC SIGNS AND BARRICADES PRIOR TO THE ACTUAL STREET CLOSING.

- NOTIFY EACH RESIDENT OR PROPERTY OWNER OF WORK WHICH WILL IMPACT ACCESS TO HIS PROPERTY A MINIMUM OF 2 BUSINESS DAYS IN ADVANCE OF RESTRICTING ACCESS TO THE PROPERTY.

- C. LANE/ROAD RESTRICTION REQUIREMENTS
- DO NOT UNDULY OR UNNECESSARILY RESTRICT OR IMPEDE NORMAL TRAFFIC THROUGH THE STREETS OF THE COMMUNITY. KEEP THE TRAVELED WAY OF ALL STREETS, ROADS, AND ALLEYS CLEAR AND UNOBSTRUCTED. DO NOT USE STREETS, ROADS, OR ALLEYS FOR THE STORAGE OF CONSTRUCTION MATERIALS, EQUIPMENT SUPPLIES, OR EXCAVATED EARTH, EXCEPT WHEN AND WHERE NECESSARY.
  - ADJACENT STREET SEGMENTS SHALL NOT BE CLOSED AT THE SAME TIME TO REDUCE DELAYS FOR EMERGENCY RESPONDERS. FOR THIS REQUIREMENT, AN "ADJACENT STREET SEGMENT" SHALL INCLUDE THE NEXT BLOCK OF THE SAME STREET IN EITHER DIRECTION, THE SAME BLOCK OF A PARALLEL STREET IN EITHER DIRECTION, AND THE NEAREST BLOCKS OF PERPENDICULAR (CONNECTING) STREETS IN ALL DIRECTIONS.
  - THE PUBLIC STREETS SHALL REMAIN OPEN AND UNRESTRICTED BY CONSTRUCTION ACTIVITIES AT ALL TIMES.
  - DAILY LANE CLOSURES ON THE PUBLIC STREETS COUNTY ROAD 14, PITTSBURGH AVENUE, AND CHICAGO AVENUE MAY BE PERMITTED. LANE CLOSURES ARE ONLY PERMISSIBLE BETWEEN 7:00 AM AND 5:00 PM, WEEKDAYS, UNLESS OTHERWISE PROVIDED, MAINTAIN AT LEAST ONE 12 FOOT WIDE LANE OF TRAFFIC AT ALL STREETS AND SERVICE DRIVES DURING CONSTRUCTION OF THE PROJECT. PROVIDE FLAGMEN OR TEMPORARY SIGNALS WHERE REQUIRED TO MAINTAIN FLOW OF TRAFFIC. DURING NON-CONSTRUCTION HOURS, OPEN ALL LANES FOR PUBLIC USE.
  - THE CONTRACTOR MAY LIMIT OR PROHIBIT PUBLIC PARKING WITHIN THE LIMITS OF THE PROJECT.
  - IF REQUIRED BY DULY CONSTITUTED PUBLIC AUTHORITY, CONSTRUCT BRIDGES OR OTHER TEMPORARY CROSSING STRUCTURES OVER TRENCHES AT NO ADDITIONAL COST TO OWNER. SUCH STRUCTURES SHALL BE OF ADEQUATE STRENGTH AND PROPER CONSTRUCTION AND SHALL BE MAINTAINED IN SUCH MANNER AS NOT TO CONSTITUTE AN UNDUE TRAFFIC HAZARD.\*

SECTION 01500 3.05-3.06:

- \*3.05 BARRICADES, WARNING LIGHTS AND ARROW BOARDS
- PROVIDE, ERECT, AND MAINTAIN ALL NECESSARY BARRICADES, SUITABLE AND SUFFICIENT DANGER SIGNALS, AND SIGNS. TAKE ALL NECESSARY PRECAUTIONS FOR THE PROTECTION AND SAFETY OF THE PUBLIC, WORKMEN, STRUCTURES, AND EQUIPMENT. ROADS CLOSED TO TRAFFIC SHALL BE PROTECTED BY EFFECTIVE BARRICADES. OBSTRUCTIONS SHALL BE ILLUMINATED DURING HOURS OF DARKNESS.
  - ERECT WARNING SIGNS IN ADVANCE OF ANY LOCATION ON THE PROJECT WHERE OPERATIONS MAY INTERFERE WITH THE USE OF THE ROAD BY TRAFFIC AND AT ALL INTERMEDIATE POINTS WHERE THE NEW WORK CROSSES OR COINCIDES WITH AN EXISTING ROAD.
  - PLACE SUFFICIENT WARNING LIGHTS AND ARROW BOARDS ON OR NEAR THE WORK AND KEEP THEM ILLUMINATED DURING PERIODS OF CONSTRUCTION AND REDUCED VISIBILITY (FROM TWILIGHT IN THE EVENING UNTIL SUNRISE). THE CONTRACTOR IS RESPONSIBLE FOR ALL DAMAGES THAT OWNER OR ANY OTHER PARTY MAY SUSTAIN IN CONSEQUENCES OF NEGLECTING THE NECESSARY PRECAUTIONS IN PROSECUTING THIS WORK.
- 3.06 REMOVAL AND CLEAN UP
- REMOVE ALL TEMPORARY FACILITIES, UTILITIES, SERVICES AND MATERIALS UPON COMPLETION OF CONSTRUCTION. REMOVE DEBRIS AND CLEAN AREA. REPAIR ALL DAMAGE AND RESTORE AREA TO FINISH CONDITION.\*

4. FOR AIR/DUST CONTROL, REFER TO THE FOLLOWING SECTION(S) OF THE SPECIFICATIONS

- SECTION 02101 3.05 (D):
- \*DUST CONTROL
- USE WATER TO DAMPEN SURFACES TO MINIMIZE DUST AND PREVENT WIND EROSION.
  - DO NOT RINSE SURFACES WITH WATER UNLESS WATER IS COLLECTED AND DISPOSED OF PROPERLY.
  - IMPLEMENT DUST CONTROL METHODS ON A ROUTINE BASIS WHEN CONSTRUCTION WARRANT.
  - PROVIDE WATER AND DUST SUPPRESSION WHEN REQUESTED BY THE ENGINEER.\*

5. FOR AIR/DUST CONTROL CONTROL, REFER TO NOTE BELOW:

AIR POLLUTION IS GENERATED FROM FACTORY, STORES, EQUIPMENT AND NATURALLY OCCURRING SOURCES SUCH AS WINDBLOWN DUST. SHORT-TERM AIR QUALITY IMPACTS FOR THE PROPOSED PROJECT MAY GENERATE DUST AND NOISE DURING CONSTRUCTION. THE PROJECT AREA INCLUDES ADJACENT TO AGRICULTURAL, RESIDENTIAL, INDUSTRIAL, AND UNDEVELOPED AREAS. MITIGATION MEASURES INCLUDE LIMITING CONSTRUCTION ACTIVITY TO DAYLIGHT HOURS ON WEEKDAYS TO MINIMIZE NOISE EFFECTS. CONSTRUCTION SPECIFICATIONS WILL REQUIRE PROPER MEASURES BE UTILIZED TO CONTROL WIND EROSION FROM CONSTRUCTION AREAS. PROPER CLEANUP PRACTICES WILL BE REQUIRED TO REDUCE THE GENERATION OF DUST. ALL OTHER CONSTRUCTION DEBRIS. WHEN IMPACTS CANNOT BE AVOIDED, APPROPRIATE MEASURES SHALL BE UTILIZED TO LIMIT SHORT TERM AIR QUALITY IMPACTS ARE NOT EXPECTED FOR THIS PROJECT.

6. FOR NOISE CONTROL, REFER TO THE FOLLOWING SECTION(S) OF THE SPECIFICATIONS

- SECTION 00510 7.02
- LABOR: WORKING HOURS
- CONTRACTOR SHALL PROVIDE COMPETENT, SUITABLY QUALIFIED PERSONNEL TO SURVEY AND LAY OUT THE WORK AND PERFORM CONSTRUCTION AS REQUIRED BY THE CONTRACT DOCUMENTS. CONTRACTOR SHALL AT ALL TIMES MAINTAIN GOOD DISCIPLINE AND ORDER AT THE SITE.
  - EXCEPT AS OTHERWISE REQUIRED FOR THE SAFETY OR PROTECTION OF PERSONS OR THE WORK OR PROPERTY AT THE SITE OR ADJACENT THERETO, AND EXCEPT AS OTHERWISE STATED IN THE CONTRACT DOCUMENTS, ALL WORK AT THE SITE SHALL BE PERFORMED DURING REGULAR WORKING HOURS, MONDAY THROUGH FRIDAY. CONTRACTOR WILL NOT PERFORM WORK ON A SATURDAY, SUNDAY, OR ANY LEGAL HOLIDAY. CONTRACTOR MAY PERFORM WORK OUTSIDE REGULAR WORKING HOURS OR ON SATURDAYS, SUNDAYS, OR LEGAL HOLIDAYS ONLY WITH OWNER'S WRITTEN CONSENT, WHICH WILL NOT BE UNREASONABLY WITHHELD.\*

7. FOR TREES/VEGETATION PROTECTION, REFER TO THE FOLLOWING SECTION(S) OF THE SPECIFICATIONS

- SECTION 02101 3.12:
- \*SCHEDULES
- COORDINATE EROSION AND SEDIMENT CONTROL MEASURES WITH CONSTRUCTION ACTIVITIES SO CONTROLS ARE IN PLACE BEFORE CONSTRUCTION BEGINS.
  - INSTALL THE TEMPORARY CONSTRUCTION ENTRANCE AND SEDIMENT TRAPS OR FILTERS BEFORE CLEARING AND GRADING BEGINS.
  - INSTALL TEMPORARY PERIMETER CONTROLS (E.G., SILT FENCES AND INLET PROTECTION) BEFORE CLEARING AND GRADING BEGINS.
  - DO NOT CLEAR, GRUB OR GRADE UNTIL IT IS NECESSARY FOR CONSTRUCTION TO PROCEED. MAINTAIN NATURAL VEGETATION AND VEGETATED BUFFERS WHEN PRACTICAL TO REDUCE THE NEED FOR CONTROL DEVICES. MAINTAIN ALL CONTROLS AS DESCRIBED THROUGHOUT THE CONSTRUCTION PROJECT AND UNTIL UPSTREAM DRAINAGE AREAS ARE STABILIZED.

- PERMANENTLY STABILIZE BARE SOILS ONCE CONSTRUCTION ACTIVITIES CEASE IN AN AREA.\*

8. FOR DEWATERING ACTIVITY, REFER TO THE FOLLOWING SECTION(S) OF THE SPECIFICATIONS

- SECTION 02101 3.05 (E):
- \*PUMPING BAGS
- INSTALL PUMPING BAGS ACCORDING TO THE DRAWINGS.
  - PROVIDE PUMPING BAGS TO FILTER SEDIMENT FROM DEWATERING OPERATIONS.
  - PROPERLY DISPOSE OF USED PUMPING BAGS.
  - APPROPRIATELY SIZE THE BAGS FOR THE AMOUNT OF FLOW.
  - USE PUMPING BAGS ON AN EROSION RESISTANT SURFACE.
  - DO NOT DISCHARGE SEDIMENT-LADEN WATER FROM DEWATERING OPERATIONS INTO OR NEAR STORMWATER CONVEYANCES, WETLANDS, RIVERS, STREAMS, AND IMPOUNDMENTS OR INTO NATURALLY FORMED CHANNELS LEADING THERETO. REFER ALSO TO SECTION 02102 FOR THE DISPOSAL OF SEDIMENT-LADEN WATER.
9. FOR STREAM CROSSINGS, REFER TO NOTE BELOW:
- THE PROJECT PROPOSES TO AVOID IMPACTS TO THE FLOODWAYS.

10. FOR ARCHAEOLOGICAL/HISTORICAL RESOURCES, REFER TO NOTE BELOW:

ANY EXCAVATION BY THE CONTRACTOR THAT UNCOVERS A HISTORICAL OR ARCHAEOLOGICAL ARTIFACT SHALL BE IMMEDIATELY REPORTED TO THE OWNER AND THE UNITED STATES DEPARTMENT OF AGRICULTURE (USDA) STATE ENVIRONMENTAL COORDINATOR. CONSTRUCTION SHALL BE TEMPORARILY HALTED PENDING THE NOTIFICATION PROCESS AND FURTHER DIRECTIONS ISSUED BY THE AGENCY.

11. FOR GROUNDWATER/DRINKING WATER PROTECTIONS, REFER TO THE FOLLOWING SECTION(S) OF THE SPECIFICATIONS

- SECTION 02101 3.09
- WORKING NEAR WATER WELLS
- WATER WELL AQUIFERS ARE TO BE PROTECTED FROM CONSTRUCTION ACTIVITIES AND POTENTIAL POLLUTION SOURCES.
- IDENTIFY WATER WELLS FEATURES ON THE DRAWINGS.
  - IMPLEMENT EROSION AND SEDIMENT CONTROL PRACTICES TO REDUCE SEDIMENTATION INTRODUCTION INTO GROUNDWATER.
  - POSITION CONSTRUCTION MATERIALS AND EQUIPMENT SO THAT THE AREA SLOPES AWAY FROM WELLS.
  - PROVIDE SECONDARY CONTAINMENT FOR ALL CHEMICALS, FUELS, OR OTHER LIQUIDS TO CAPTURE SPILLS OR LEAKS.
  - CLEAN UP SPILLS WITH ABSORBENTS OR DRY METHODS. DO NOT ALLOW SPILLS TO SOAK INTO THE GROUND AND DO NOT WASH OFF WITH WATER OR DETERGENTS.
  - PROPERLY DISPOSE OF WASTE MATERIALS.\*

SECTION 02220 3.03

- \*3.03 CONTAMINATED SOILS AND GROUNDWATER
- IF SUSPECTED CONTAMINATED SOILS OR GROUNDWATER ARE DISCOVERED DURING EXCAVATION, INFORM THE ENGINEER IMMEDIATELY AND CEASE EXCAVATION.
  - CONTACT THE CORRESPONDING REGULATORY AGENCY BASED ON THE EXCAVATION LOCATION.
- IF THE EXCAVATION IS WITHIN THE ODOT RIGHT-OF-WAY, CONTACT ODOT OFFICE OF ENVIRONMENTAL SERVICES (614-728-7368) AND REPORT THE SUSPECTED CONTAMINATION TO THE OHIO ENVIRONMENTAL PROTECTION AGENCY'S (EPA) 24-HOUR SPILL HOTLINE (800-282-9378). FOLLOW ODOT SITE ASSESSMENT GUIDELINES FOR PROPER INVESTIGATION AND HANDLING OF THE SUSPECTED CONTAMINATED SOILS OR GROUNDWATER.
  - IF THE EXCAVATION IS OUTSIDE OF THE ODOT RIGHT-OF-WAY, THE OWNER WILL REPORT THE SUSPECTED CONTAMINATION TO OHIO EPA 24-HOUR SPILL HOTLINE. OHIO EPA MAY DIRECT THE OWNER TO ADDITIONAL REGULATORY AGENCIES DEPENDING ON THE NATURE OF THE SUSPECTED CONTAMINATION.
    - KEEP SUSPECTED CONTAMINATED SOILS SEPARATE FROM SOILS THAT APPEAR TO BE "CLEAN" OR UNCONTAMINATED.
  - DO NOT PLACE SUSPECTED CONTAMINATED SOILS, IN ENVIRONMENTALLY SENSITIVE AREAS SUCH AS WATERWAYS, FLOODWAYS, WETLANDS, KARST FEATURES, OR STORMWATER CONVEYANCES.
  - PLACE SUSPECTED CONTAMINATED SOIL ON A PLASTIC TARP AND COVER WITH AN ADDITIONAL PLASTIC TARP OR PLACE IN CONTAINERS (E.G., DRUMS) WITH A LID.
  - PLACE A BERM AROUND THE COVERED STOCKPILE TO ENSURE THAT SOILS ARE NOT BLOWN BY WIND OR CARRIED BY STORMWATER.
  - FOLLOW THE DIRECTION OF THE REGULATORY AGENCY IN HANDLING, STORAGE, CHARACTERIZATION, AND DISPOSAL OF CONTAMINATED SOILS.
    - LEAVE SUSPECTED CONTAMINATED GROUNDWATER IN THE EXCAVATED AREA.
  - IF THE SUSPECTED CONTAMINATED GROUNDWATER MUST BE REMOVED FROM THE EXCAVATED AREA, PUMP TO COVERED CONTAINERS (E.G., DRUMS OR TOTES) FOR PROPER DISPOSAL.
  - FOLLOW ALL FEDERAL, STATE, AND LOCAL DISPOSAL REQUIREMENTS FOR SUSPECTED CONTAMINATED GROUNDWATER.
    - DISCHARGING CONTAMINATED GROUNDWATER TO A WATERWAY OR STORMWATER CONVEYANCE REQUIRES AN EMERGENCY NPDES PERMIT FROM OHIO EPA'S STORM WATER PROGRAM. THE CONTAMINATED GROUNDWATER MUST MEET THE NPDES DRINKING WATER QUALITY STANDARDS. CONTAMINATED GROUNDWATER MAY NOT BE DISCHARGED UNTIL THE PERMIT IS OBTAINED (TYPICALLY 90 DAYS).
    - DISCHARGING CONTAMINATED GROUNDWATER TO THE SANITARY SEWER REQUIRES LOCAL APPROVAL AND ANALYTICAL TESTS PER THE LOCAL SEWER USE ORDINANCE OR WASTEWATER DISCHARGE REQUIREMENTS.
    - ANY INCREASE OR DECREASE OF COST RESULTING FROM ENCOUNTERING CONTAMINATED SOILS OR GROUNDWATER WILL BE ADJUSTED IN THE MANNER PROVIDED IN THE CONTRACT DOCUMENTS.\*

12. FOR SOIL CONDITIONS AND GROUNDWATER, REFER TO NOTE BELOW:

DEWATERING MAY BE REQUIRED TO TEMPORARILY LOWER THE GROUNDWATER TABLE IN SOME AREAS DURING CONSTRUCTION. MINOR FLUCTUATIONS IN GROUNDWATER LEVELS WILL BE TEMPORARY IN NATURE. DISCHARGE FROM DEWATERING ACTIVITIES WILL BE FILTERED OR SETTLED TO REMOVE SEDIMENT AND WILL NOT BE DIRECTLY DISCHARGED TO ANY WATERWAY, WETLAND, OR STORMWATER CONVEYANCE.

Drawing: X:\Highgate\_OH\703222\_Highgate\_WTP\Contract B - Booster Station and WTP\DWG Sheets\703222-EC.dwg | Layout: TEC3 | Plotter: TEC3 | Printer: 01/21/26 @ 03:07:44 | LaseSweetBy: CnsHG



SCALE VERIFICATION  BAR IS ONE INCH LONG ON ORIGINAL DRAWING  	DRAWN BY	CLG	NO.	DATE	INITIALS	REVISION DESCRIPTIONS		<p>W WESSLER ENGINEERING More than a Project™</p>	<p><b>WATER SYSTEM IMPROVEMENTS</b></p> <p>CONTRACT B NEW BOOSTER STATION AND WATER TREATMENT PLANT IMPROVEMENTS VILLAGE OF HOLGATE, OHIO</p>	SHEET NO.
	CHECKED BY	MAP								<p><b>7EC3</b></p>
	APPROVED BY	AMS								
	ISSUE DATE	FEBRUARY 2026							PAGE NO. <p><b>45</b></p>	
	PROJECT NUMBER	703222-04-001							DDAGW-4113 02/20/2026	
<p><b>EROSION CONTROL DETAILS</b></p>										

Drawing: X:\Hogdale\_Chi703222\_Hogdale WTP\Contract B - Booster Station and WTP\DWG\Sheets\703222-EL-000.dwg | Layout: BE1 | Plotter: 012128 @ 32.5x44.3 | LastSavedBy: jshah

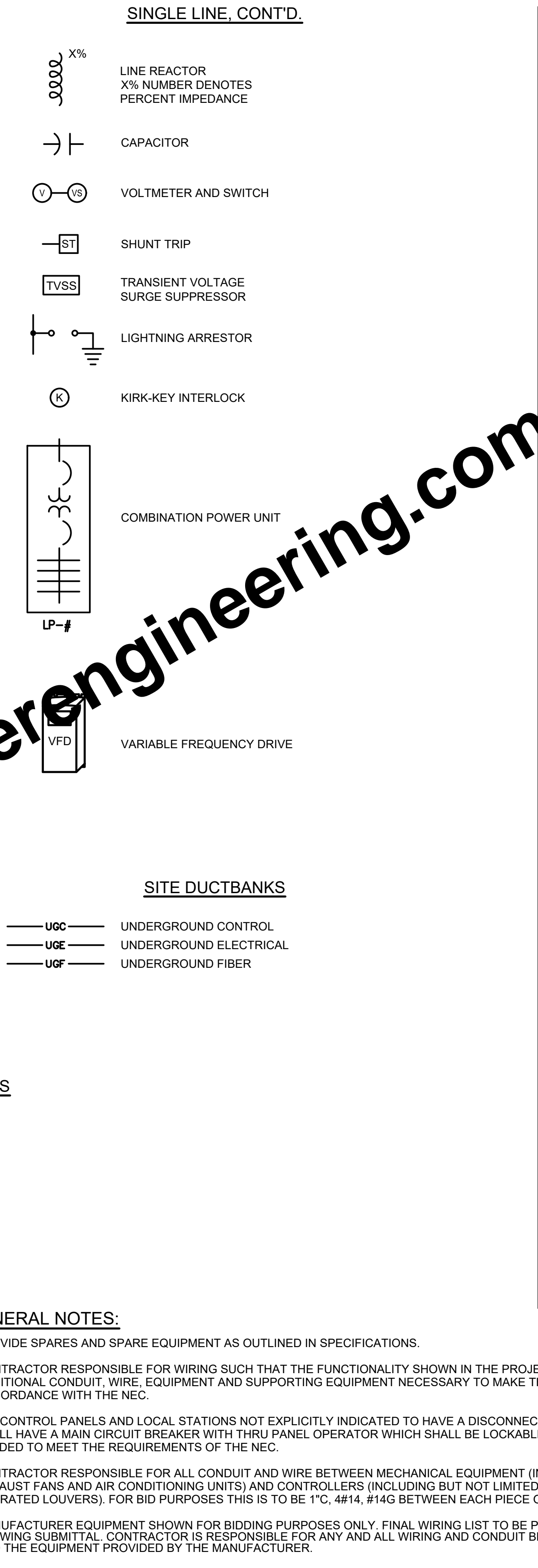
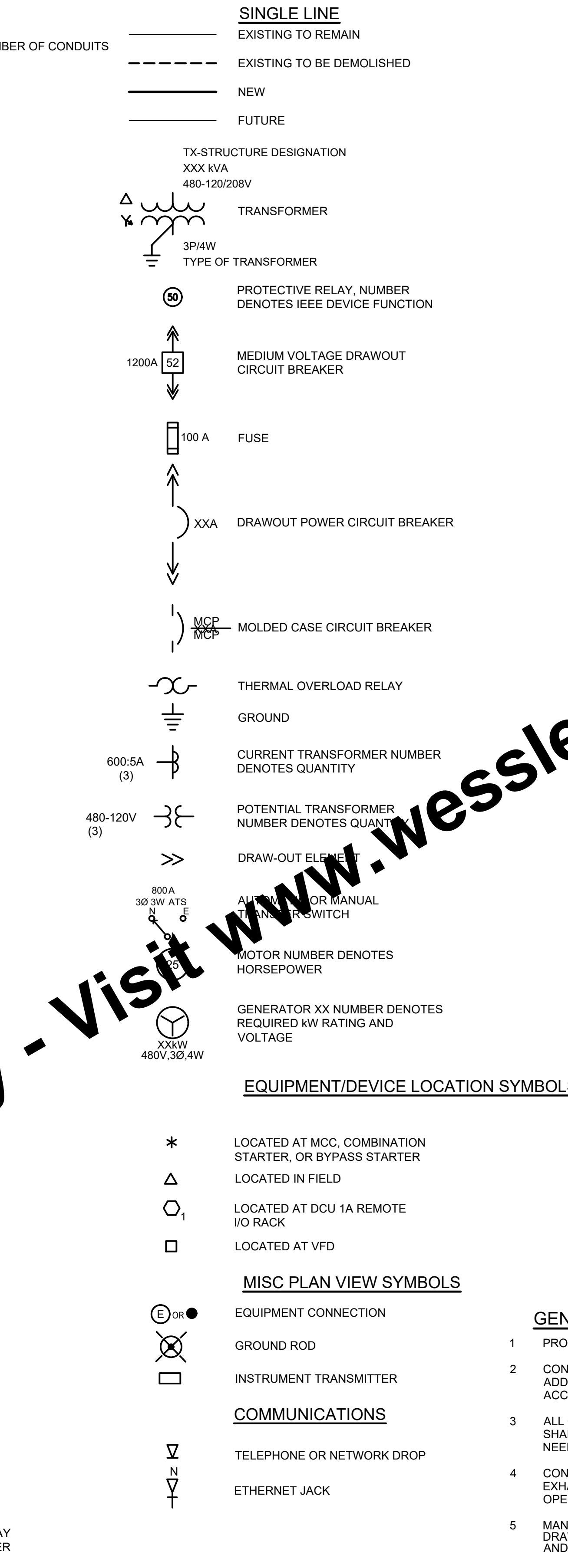
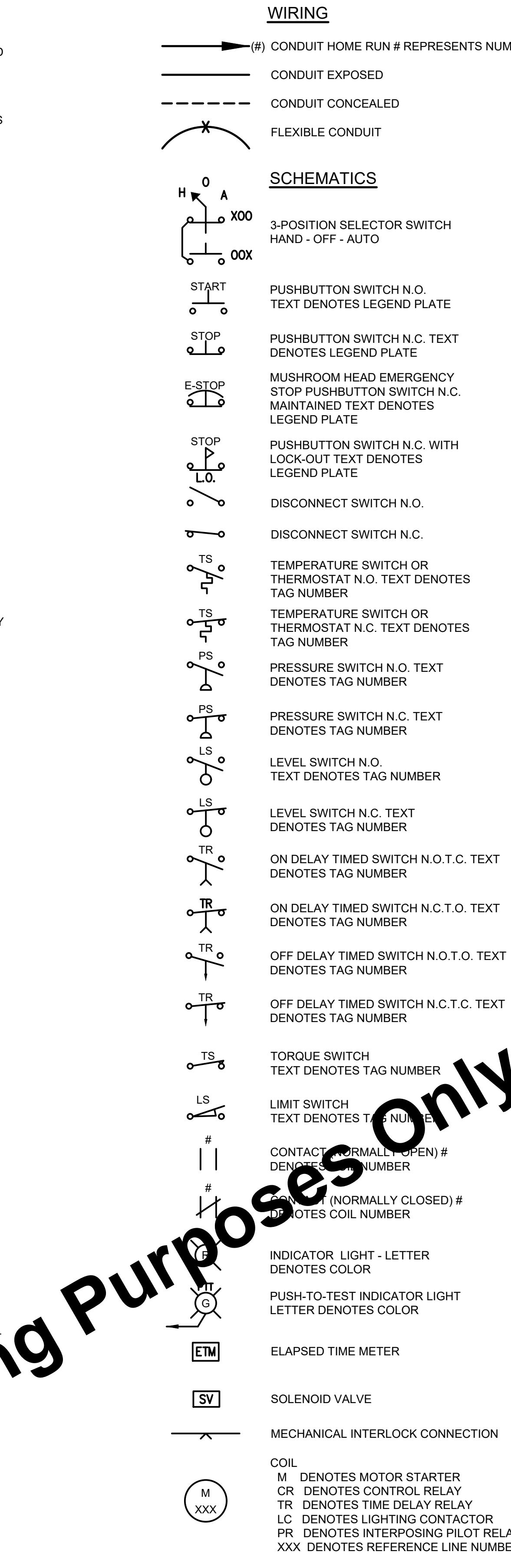
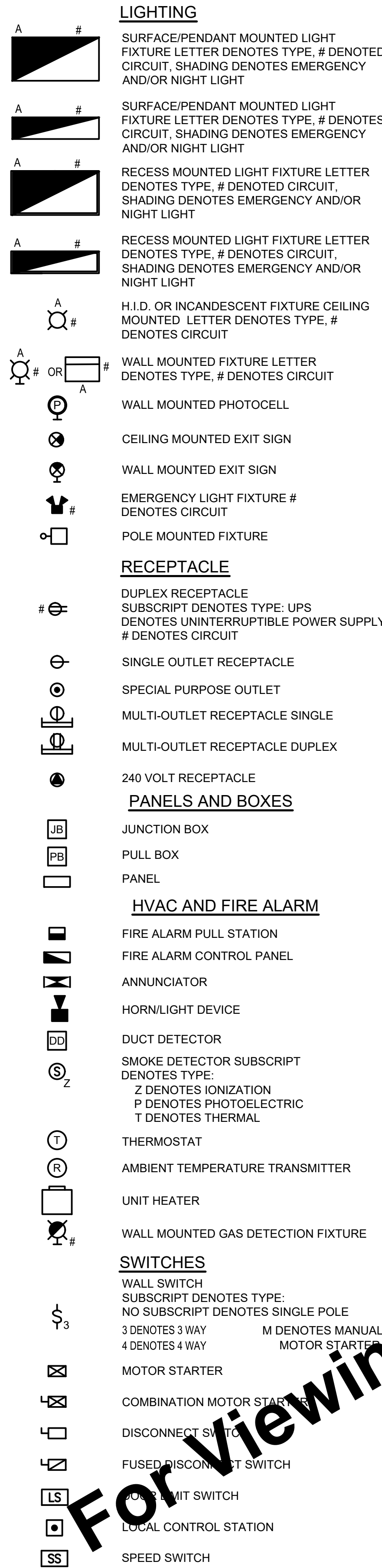

**ABBREVIATIONS**

A	AMPERE(S)	MAN	MANUFACTURER SUPPLIED (EX. MAN-CP)
ACU	AIR CONDITIONING UNIT	MAU	MAKEUP AIR UNIT
AE	ANALYTICAL SENSOR	MCC	MOTOR CONTROL CENTER
AF	AMP FRAME	MH	MANHOLE
AFF	ABOVE FINISHED FLOOR	MOL	MOTOR OPERATED LOUVER
AHU	AIR HANDLING UNIT	MPU	MINI POWER UNIT
AIT	ANALYTICAL INDICATOR TRANSMITTER	MV	MEDIUM VOLTAGE
AM	AMMETER	N	NEUTRAL
AMP	AMPERE(S)	N/A	NOT APPLICABLE
AT	AMP TRIP	NC	NORMALLY CLOSED
ATL	ACROSS THE LINE (STARTER)	NEC	NATIONAL ELECTRICAL CODE
ATS	AUTOMATIC TRANSFER SWITCH	NET	NETWORK (PANEL)
AUX	AUXILIARY	NF	NON-FUSED
AWG	AMERICAN WIRE GAGE	NFSS	NON-FUSED SAFETY SWITCH
BKR	BREAKER	N.O.	NORMALLY OPEN
BLDG	BUILDING	NTS	NOT TO SCALE
C	CIRCUIT	OL	OVERLOAD
CB	CIRCUIT BREAKER	PB	PUSHBUTTON
CKT	CIRCUIT	PLC	PROGRAMMABLE LOGIC CONTROLLER
CP	CONTROL PANEL	PM	POWER METER/MONITOR
CR	CORROSION RESISTANT	PNL	PANEL
CU	COPPER	PP	POWER PANEL
DF	DUCT FAN	RCPT	RECEPTACLE
DH	DUCT HEATER	RGS	RIGID GALVANIZED STEEL
DISC	DISCONNECT	RIO	REMOTE INPUT/OUTPUT
EF	EXHAUST FAN	R/S	RING SWITCH
ELEV	ELEVATION	RVSS	REDUCED VOLTAGE SOFT STARTER
EMH	ELECTRICAL MANHOLE	RVAT	REDUCED VOLTAGE AUTOTRANSFORMER
EMT	ELECTRICAL METALLIC TUBING	SF	SUPPLY FAN
EQUIP	EQUIPMENT	SHLD	SHIELDED
EWC	ELECTRICAL WATER COOLER	SOL	SOLENOID
EXP	EXPLOSION PROOF	SP	SINGLE POLE
F	FUSED OR FUSE	SPD	SURGE PROTECTIVE DEVICE
FE	FLOW SENSOR	SST	STAINLESS STEEL
FIT	FLOW INDICATOR TRANSMITTER	STR	STARTER
FLA	FULL LOAD AMPS	SW	SWITCH
FOPP	FIBER OPTIC PATCH PANEL	SWBD	SWITCHBOARD
FV(N)R	FULL VOLTAGE (NON) REVERSING	SWGR	SWITCHGEAR
G	GROUND	TB	TERMINAL BOX
GEN	GENERATOR	TPS	TWISTED PAIR SHIELDED
GF	GROUND FAULT	TYP	TYPICAL
GF(C)I	GROUND FAULT (CIRCUIT) INTERRUPTER	UGE	UNDERGROUND ELECTRICAL
HH	HANDHOLE	UGT	UNDERGROUND TELEPHONE
HOA	HAND-OFF-AUTOMATIC	UGCC	UNDERGROUND CONTROLS CABLE
HOR	HAND-OFF-REMOTE	UGF	UNDERGROUND FIBER
HP	HORSEPOWER	UH	UNIT HEATER
HPS	HIGH PRESSURE SODIUM	UL	UNDERWRITERS LABORATORIES
JB	JUNCTION BOX	UNO	UNLESS NOTED OTHERWISE
KV	KILOVOLTS	V	VOLTS
KVA	KILOVOLTS AMPS	VFD	VARIABLE FREQUENCY DRIVE
KVAR	KILOVAR	VM	VOLTMETER
KW	KILOWATTS	VS	VOLTMETER SWITCH
LCP	LOCAL CONTROL PANEL	W	WIRE/WATT
LCS	LOCAL CONTROL STATION	WH	WATER HEATER
LE	LEVEL SENSOR	WP	WEATHERPROOF
LIT	LEVEL INDICATING TRANSMITTER	XFMR	TRANSFORMER
LOR	LOCAL-OFF-REMOTE		
LP	LIGHTING PANEL		
LTG	LIGHTING		
LV	LOW VOLTAGE		

For Viewing Purposes Only - Visit [www.wesslerengineering.com](http://www.wesslerengineering.com) to Purchase

SCALE VERIFICATION	DRAWN BY	JLK	NO.	DATE	INITIALS	REVISION DESCRIPTIONS
BAR IS ONE INCH LONG ON ORIGINAL DRAWING	CHECKED BY	JAP				
	APPROVED BY	WCM				
	ISSUE DATE	FEBRUARY 2026				
	PROJECT NUMBER	703222-04-001				

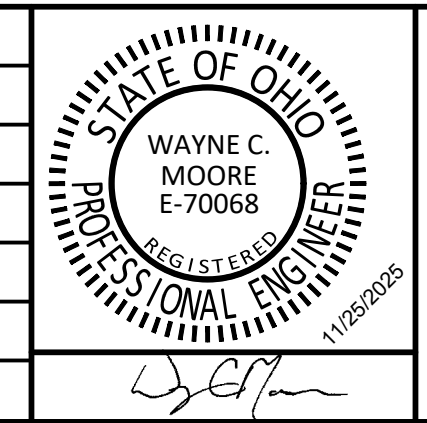

**WATER SYSTEM IMPROVEMENTS**

CONTRACT B NEW BOOSTER STATION AND WATER TREATMENT PLANT IMPROVEMENTS  
VILLAGE OF HOGGATE, OHIO

**ELECTRICAL LEGEND**

SHEET NO.	8E1
PAGE NO.	46
DDAGW-4113	



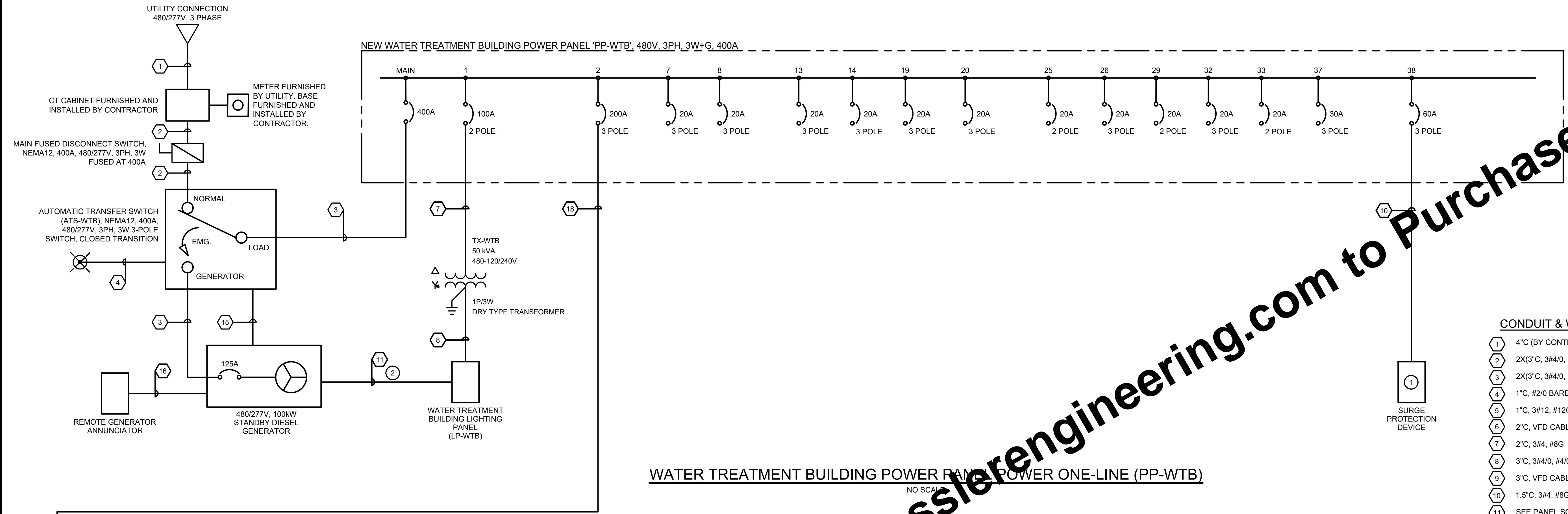

WATER TREATMENT BUILDING POWER PANEL POWER ONE-LINE (PP-WTB)  
NO SCALE

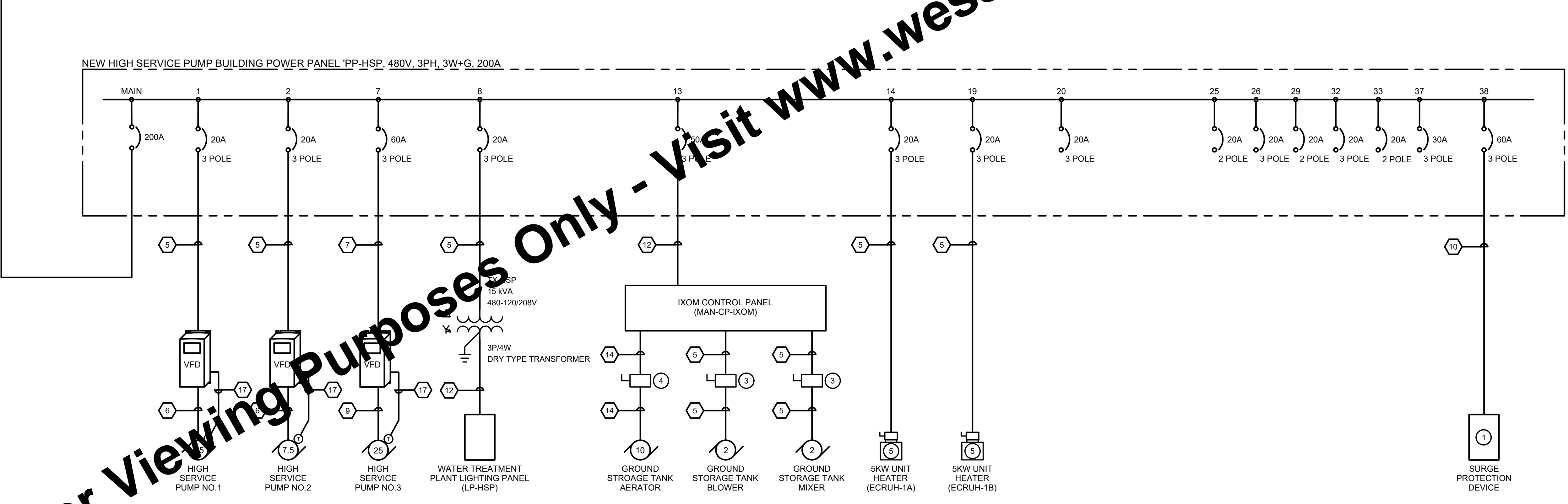

HIGH SERVICE PUMP BUILDING POWER PANEL POWER ONE-LINE (PP-HSP)  
NO SCALE

- CONDUIT & WIRE SCHEDULE:**
- ① 4" (BY CONTRACTOR), UTILITY FURNISHED WIRE
  - ② 2X(3" C, 3#4/0, #4/0N)
  - ③ 2X(3" C, 3#4/0, #2G)
  - ④ 1" C, #2/0 BARE COPPER GROUND
  - ⑤ 1" C, 3#12, #12G
  - ⑥ 2" C, VFD CABLE 3#12 WITH SYM. GROUND (BELDEN OR EQ.)
  - ⑦ 2" C, 3#4, #8G
  - ⑧ 3" C, 3#4/0, #4/0N, #4G
  - ⑨ 3" C, VFD CABLE 3#4 WITH SYM. GROUND (BELDEN OR EQ.)
  - ⑩ 1.5" C, 3#4, #8G
  - ⑪ SEE PANEL SCHEDULE
  - ⑫ 1.5" C, 3#6, #10G AND 2" C SPARE
  - ⑬ 1" C, 3#10, #10G
  - ⑭ 1" C, 3#8, #10G
  - ⑮ 3/4" C, 8#14, #14G
  - ⑯ 3/4" C, 2" C TPS #14
  - ⑰ 3/4" C, 2#12, #12G
  - ⑱ 3" C, 3#4/0, #2G AND 3" C SPARE

- KEYED NOTES:**
- ① SEE PANELBOARD SPECIFICATION FOR SPD INFORMATION
  - ② THREE (3) CIRCUITS ARE SHOWN BETWEEN LP-WTP AND NEW GENERATOR. MISCELLANEOUS GENERATOR LOADS VARY BY MODEL/MANUFACTURER. CONTRACTOR TO PROVIDE THESE CIRCUITS AND ANY OTHERS REQUIRED TO PROVIDE POWER FOR MISCELLANEOUS GENERATOR LOADS.
  - ③ 480V, 30A, 3P, NEMA4X, NON-FUSIBLE DISCONNECT
  - ④ 480V, 60A, 3P, NEMA4X, NON-FUSIBLE DISCONNECT
  - ⑤ UNIT HEATER PROVIDED WITH INTEGRAL DISCONNECT BY MANUFACTURER.

- GENERAL NOTES:**
1. ALL INDOOR ELECTRICAL ENCLOSURES SHALL BE NEMA12 RATED AT MINIMUM UNLESS INDICATED OTHERWISE.
  2. ALL EXTERIOR ELECTRICAL ENCLOSURES SHALL BE NEMA4X RATED AT MINIMUM UNLESS INDICATED OTHERWISE.

For Viewing Purposes Only - Visit [www.wesslerengineering.com](http://www.wesslerengineering.com) to Purchase

SCALE VERIFICATION	DRAWN BY	JLK	NO.	DATE	INITIALS	REVISION DESCRIPTIONS
BAR IS ONE INCH LONG ON ORIGINAL DRAWING	CHECKED BY	JAP				
	APPROVED BY	WCM				
	ISSUE DATE	FEBRUARY 2026				
	PROJECT NUMBER	703222-04-001				

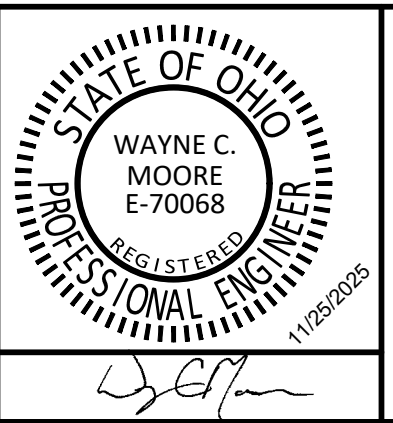

**WATER SYSTEM IMPROVEMENTS**

CONTRACT B NEW BOOSTER STATION AND WATER TREATMENT PLANT IMPROVEMENTS  
VILLAGE OF HOLGATE, OHIO

---

**WATER TREATMENT BUILDING POWER ONE LINE DIAGRAM**

SHEET NO.  
**8E2**

PAGE NO.  
**47**

DDAGW-4113  
02/20/2026

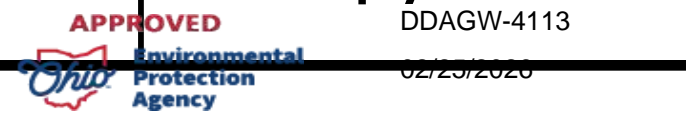

Drawing: X:\Holgeatle\_OH\703222\_Holgeatle\_WTP\Contract B - Booster Station and WTP\DWG\Sheets\703222-EL-001.dwg | Layout: BEZ | Plotter: 01/21/26 @ 05:50:46 | LastSavedBy: jshk

Drawing: X:\Hogdale\_Chi\703222\_Hogdale WTP\Contract B - Booster Station and WTP\DWG\Sheets\703222-EL-001.dwg | Plotter: 012126 @ 02:50:48 | LastSavedBy: jshk

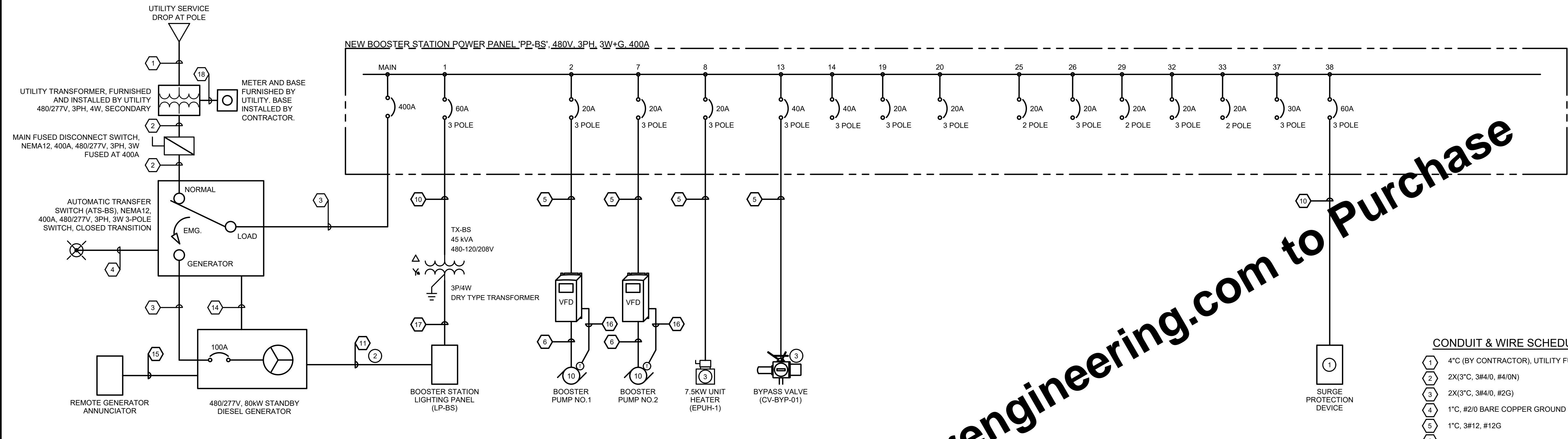

**BOOSTER STATION POWER PANEL POWER ONE-LINE (PP-BS)**

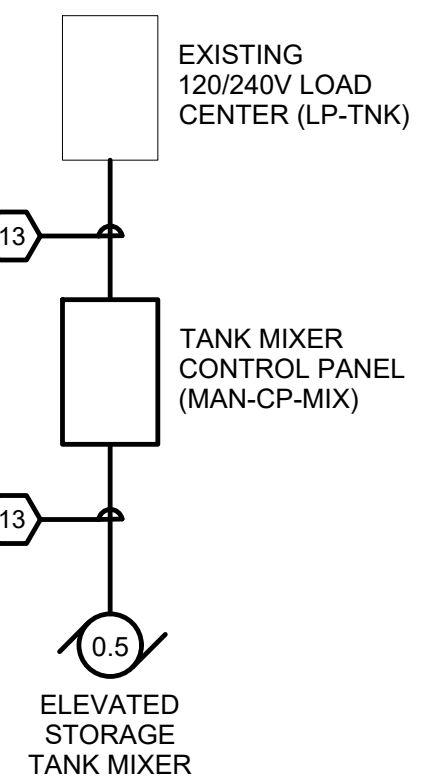

**EXISTING ELEVATED STORAGE TANK ONE LINE DIAGRAM**

**CONDUIT & WIRE SCHEDULE:**

1	4" (BY CONTRACTOR), UTILITY FURNISHED WIRE
2	2X(3"C, 3#4/0, #4/0N)
3	2X(3"C, 3#4/0, #2G)
4	1"C, #2/0 BARE COPPER GROUND
5	1"C, 3#12, #12G
6	2"C, VFD CABLE 3#12 WITH SYM. GROUND (BELDEN OR EQ.)
7	2"C, 3#2, #6G
8	3"C, 3#4/0, #4/0N, #4G
9	3"C, VFD CABLE 3#2 WITH SYM. GROUND (BELDEN OR EQ.)
10	1.5"C, 3#4, #8G
11	SEE PANEL SCHEDULE
12	1.5"C, 3#6, #10G
13	3/4"C, 2#12, #12N, #12G
14	3/4" 8#14, #14G
15	3/4"C, 2/C TPS #14
16	3/4"C, 2#12, #12G
17	2"C, 3#1/0, #1/0N, 6G
18	1"C, UTILITY WIRE

- KEYED NOTES:**
- SEE PANELBOARD SPECIFICATION FOR SPD INFORMATION
  - THREE (3) CIRCUITS ARE SHOWN BETWEEN LP-WTP AND NEW GENERATOR. MISCELLANEOUS GENERATOR LOADS VARY BY MODEL/MANUFACTURER. CONTRACTOR TO PROVIDE THESE CIRCUITS AND ANY OTHERS REQUIRED TO PROVIDE POWER FOR MISCELLANEOUS GENERATOR LOADS.
  - EQUIPMENT TO BE PROVIDED WITH INTEGRAL DISCONNECT SWITCH.

- GENERAL NOTES:**
- ALL INDOOR ELECTRICAL ENCLOSURES SHALL BE NEMA12 RATED AT MINIMUM UNLESS INDICATED OTHERWISE.
  - ALL EXTERIOR ELECTRICAL ENCLOSURES SHALL BE NEMA4X RATED AT MINIMUM UNLESS INDICATED OTHERWISE.

For Viewing Purposes Only - Visit [www.wesslerengineering.com](http://www.wesslerengineering.com) to Purchase

SCALE VERIFICATION BAR IS ONE INCH LONG ON ORIGINAL DRAWING	DRAWN BY	JLK	NO.	DATE	INITIALS	REVISION DESCRIPTIONS
	CHECKED BY	JAP				
	APPROVED BY	WCM				
	ISSUE DATE	FEBRUARY 2026				
	PROJECT NUMBER	703222-04-001				

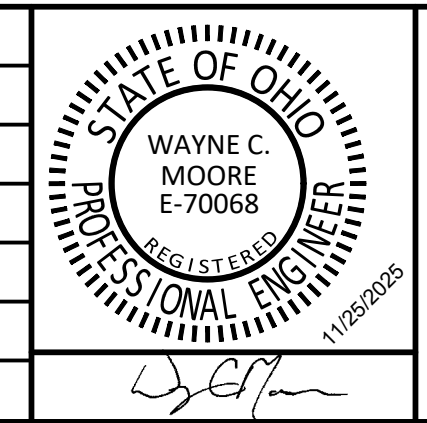

<b>WATER SYSTEM IMPROVEMENTS</b>
CONTRACT B NEW BOOSTER STATION AND WATER TREATMENT PLANT IMPROVEMENTS VILLAGE OF HOGDALE, OHIO
<b>BOOSTER STATION POWER ONE LINE DIAGRAM</b>

SHEET NO. <b>8E3</b>
PAGE NO. <b>48</b>
DDAGW-4113

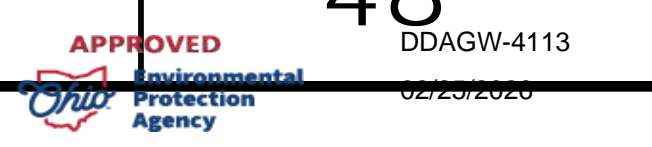

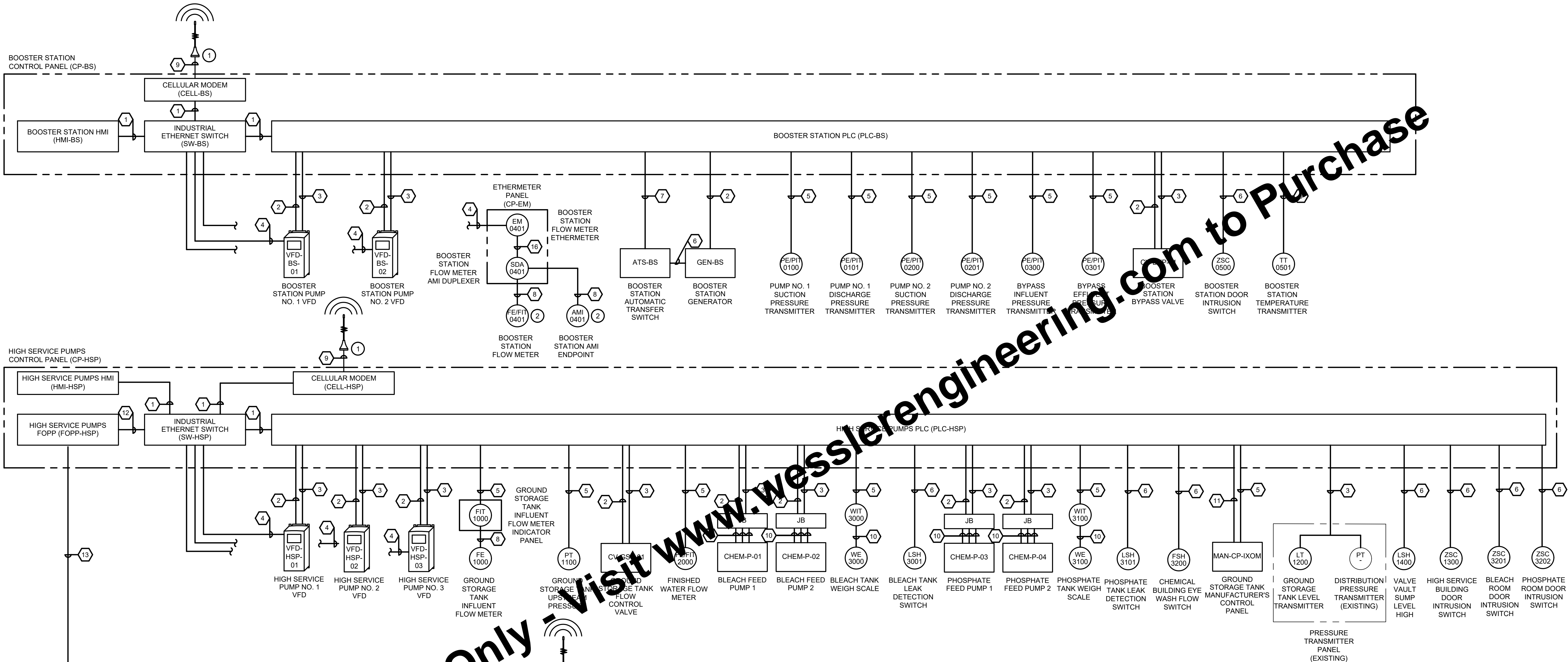

**CONDUIT AND WIRE SCHEDULE:**

- 1 CAT6 ETHERNET
- 2 3/4" C, 8#14
- 3 3/4" C, 2 - 2/C#16TPS
- 4 1" C, CAT6 ETHERNET
- 5 3/4" C, 2/C#16TPS
- 6 3/4" C, 3#14
- 7 3/4" C, 4#14
- 8 3/4" C, MANUFACTURER'S CABLE
- 9 OUTDOOR RATED COAX, NO CONDUIT
- 10 MANUFACTURER'S CABLE
- 11 1" C, 24#14
- 12 FIBER PATCH CORD
- 13 2" C, FIBER OPTIC CABLE
- 14 3/4" C, 3 - 2/C#16TPS
- 15 2/C#16TPS
- 16 4#14

**KEYED NOTES:**

- 1 CELLULAR ANTENNA TO EXIT THE BUILDING. CELLULAR ANTENNA DIRECTION AND LOCATION TO BE APPROVED BY OWNER.
- 2 PROVIDED BY NAPOLEON.
- 3 RELOCATE EXISTING CHLORINE ANALYZER. REFERENCE SHEET 4E1 FOR NEW LOCATION. MODIFY ANALYZER TO INCLUDE pH AND TEMPERATURE MEASUREMENT. REFERENCE SPECIFICATION 13420 FOR MORE DETAILS.

Drawing: X:\Highgate\_OH\703222\_Highgate\_WTP\Contract B - Booster Station and WTP\DWG\Sheets\703222-REL-04.dwg | Layout: BEA | Plotter: 01/27/20 @ 02:54:02 | LastSavedBy: Curtis

For Viewing Purposes Only - Visit www.wesslerengineering.com to Purchase

SCALE VERIFICATION BAR IS ONE INCH LONG ON ORIGINAL DRAWING	DRAWN BY	BNH	NO.	DATE	INITIALS	REVISION DESCRIPTIONS
	CHECKED BY	BDP				
	APPROVED BY	BNH				
	ISSUE DATE	FEBRUARY 2026				
	PROJECT NUMBER	703222-04-001				

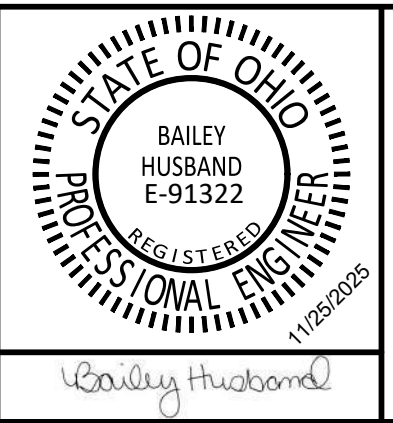

**WATER SYSTEM IMPROVEMENTS**

CONTRACT B NEW BOOSTER STATION AND WATER TREATMENT PLANT IMPROVEMENTS  
VILLAGE OF HOLGATE, OHIO

**CONTROL ONE LINE DIAGRAM**

SHEET NO.  
**8E4**

PAGE NO.  
**49**

DDAGW-4113

PANEL SCHEDULE		DESIGNATION: LP-WTB LOCATION: WATER TREATMENT BUILDING VOLTAGE: 120/240 V AC PHASE: 1 PHASE, 3 WIRE				MAINS: 200 AMP MAIN CIRCUIT BREAKER BUS SIZE: 225 AMP PANEL MOUNTING: SURFACE ALL BREAKERS: 10000 A.I.C. (MINIMUM)							
OKT. NO.	LOAD DESCRIPTION	#	KVA	OKT. BKR.		KVA		OKT. BKR.		KVA	#	LOAD DESCRIPTION	OKT. NO.
				AMPS	POLE	A	B	AMPS	POLE				
1	GAS UNIT HEATER (GFUH-1)	1	0.50	20	1	0.68		20	1	0.18	1	OUTDOOR LIGHTING	2
3	DEDICATED RECEPTACLE FOR FUTURE EQUIP	1	0.36	20	1		0.86	20	1	0.50	1	CONTROL PANEL (CP-WTB)	4
5	GARAGE LIGHTING	1	1.00	20	1	1.90		20	1	0.90	1	SOUTHWEST GARAGE RECEPTACLES	6
7	NORTHEAST GARAGE RECEPTACLES	1	0.40	20	1		0.40	20	1			SPARE	8
9	OUTDOOR RECEPTACLES	1	0.40	20	1		0.40	20	1			SPARE	10
11	LP-MECH	7	10.00	125	2		10.00	20	1			SPARE	12
13			10.00					30	1			SPARE	14
15	SPARE			20	1		0.00	20	1			SPARE	16
17	SPARE			20	1		0.00	20	1			SPARE	18
19	SPARE			20	1		0.00	20	1			SPARE	20
21	SPARE			20	1		0.00	20	1			SPARE	22
23	SPARE			20	1		0.00	20	1			SPARE	24
25	SPARE			20	1		0.00	20	1			SPARE	26
27	SPARE			20	1		0.00	20	1			SPARE	28
29	SPARE			20	1		0.00	20	1			SPARE	30
31	SPARE			20	1		0.00	20	1			SPARE	32
33	SPARE			20	1		0.00	20	1			SPARE	34
35	SPARE			20	1		0.00	20	1			SPARE	36
37	SPARE			30	1		0.00	30	1			SPARE	38
39	SPARE			30	1		0.00	30	2		4	1 SPD	40
41	SPARE			30	1		0.00	30	1				42
TOTAL CONNECTED LOAD:				12.98	11.26	TOTAL =		24.24	KVA				
# ONE (1) OR TWO (2) DIGIT NUMBERS REFER TO CONDUIT & WIRE SCHEDULE ON THIS SHEET. 33 1-pole 20A breakers, 5 1-pole 30A breakers, 1 2-pole 30A breaker, 1 2-pole 125A breaker													

WATER TREATMENT BUILDING LIGHTING PANEL (LP-WTB) SCHEDULE

SCALE: NONE

PANEL SCHEDULE		DESIGNATION: LP-MECH LOCATION: MECHANICAL ROOM VOLTAGE: 120/240 V AC PHASE: 1 PHASE, 3 WIRE				MAINS: 100 AMP MAIN CIRCUIT BREAKER BUS SIZE: 225 AMP PANEL MOUNTING: SURFACE ALL BREAKERS: 10000 A.I.C. (MINIMUM)							
OKT. NO.	LOAD DESCRIPTION	#	KVA	OKT. BKR.		KVA		OKT. BKR.		KVA	#	LOAD DESCRIPTION	OKT. NO.
				AMPS	POLE	A	B	AMPS	POLE				
1	FURNACE (SSH-1) (HEAT KIT)	5	4.00	45	2	6.00		30	2	2.00	4	HEAT PUMP (SSHP-1)	2
3			4.00				6.00	20	1	2.00			4
5	ENERGY RECOVERY VENTILATOR (ERV-1)	1	0.20	20	1	0.40		20	1	0.20	1	CONTROL PANEL (CP-HVAC)	6
7	CHLORINE ANALYZER	1	0.20	20	1		1.20	20	1	1.00	1	BLEACH ROOM RECEPTACLES	8
9	TANKLESS HOT WATER HEATER (GAS)	1	0.30	20	1	1.30		20	1	1.00	1	OFFICE/BATHROOM RECEPTACLES	10
11	OFFICE/BATHROOM/UTILITY LIGHTING	1	0.30	20	1		0.50	20	1	0.20	1	BLEACH ROOM EAST COUNTER RECEPTACLES	12
13	HALLWAY/BREAKROOM LIGHTING	1	0.50	20	1		0.70	20	1	0.20		HALLWAY/EQUIPMENT ROOM RECEPTACLES	14
15	ELECTRIC UNIT HEATER (EWUH-2)	2	1.50	20	2		1.50	20	1			SPARE	16
17			1.50			1.50		20	1			SPARE	18
19	FURNACE (SSH-1)	4	1.00	30	2		1.00	20	1			SPARE	20
21			1.00			1.00		20	1			SPARE	22
23	SPARE			20	1		0.00	20	1			SPARE	24
25	SPARE			20	1		0.00	20	1			SPARE	26
27	SPARE			20	1		0.00	20	1			SPARE	28
29	SPARE			20	1		0.00	20	1			SPARE	30
31	SPARE			20	1		0.00	20	1			SPARE	32
33	SPARE			20	1		0.00	20	1			SPARE	34
35	SPARE			20	1		0.00	20	1			SPARE	36
37	SPARE			30	1		0.00	30	1			SPARE	38
39	SPARE			30	1		0.00	30	2		4	1 SPD	40
41	SPARE			30	1		0.00	30	1				42
TOTAL CONNECTED LOAD:				10.90	10.20	TOTAL =		21.10	KVA				
# ONE (1) OR TWO (2) DIGIT NUMBERS REFER TO CONDUIT & WIRE SCHEDULE ON THIS SHEET. 28 1-pole 20A breakers, 1 2-pole 20A breaker, 4 1-pole 30A breakers, 3 2-pole 30A breakers, 1 2-pole 45A breaker													

WATER TREATMENT MECHANICAL ROOM LIGHTING PANEL (LP-MECH) SCHEDULE

SCALE: NONE

PANEL SCHEDULE		DESIGNATION: LP-BS LOCATION: HOGGATE BOOSTER STATION VOLTAGE: 120/208 V AC PHASE: 3 PHASE, 4 WIRE				MAINS: 150 AMP MAIN CIRCUIT BREAKER BUS SIZE: 225 AMP PANEL MOUNTING: SURFACE ALL BREAKERS: 10000 A.I.C. (MINIMUM)								
OKT. NO.	LOAD DESCRIPTION	#	KVA	OKT. BKR.			KVA			OKT. BKR.	KVA	#	LOAD DESCRIPTION	OKT. NO.
				AMPS	POLE	A	B	C	AMPS					
1	BOOSTER STATION CONTROL PANEL (CP-BS)	1	1.00	20	1	2.10			20	1	1.10	1	RECEPTACLE CIRCUIT 1	2
3	INDOOR LIGHTING	1	1.00	20	1		1.40		20	1	0.40	1	RECEPTACLE CIRCUIT 2	4
5	OUTDOOR LIGHTING	1	0.30	20	1			1.00	20	1	0.70	1	OUTDOOR RECEPTACLES	6
7	BOOSTER STATION MINISPLIT (SSAC-2)	4	2.00	30	2	2.00			20	1		1	SPARE DEDICATED RECEPTACLE	8
9			2.00			2.40			20	1	0.40	1	ETHERMETER PANEL (CP-BS)	10
11	SPARE			20	1			0.00	20	1			SPARE	12
13	SPARE			20	1		0.00		20	1			SPARE	14
15	SPARE			20	1		0.00		20	1			SPARE	16
17	SPARE			20	1			0.00	20	1			SPARE	18
19	SPARE			20	1			0.00	20	1			SPARE	20
21	SPARE			20	1			0.00	20	1			SPARE	22
23	SPARE			20	1			0.00	20	1			SPARE	24
25	SPARE			20	1			0.00	20	1			SPARE	26
27	SPARE			20	1			0.00	20	1			SPARE	28
29	SPARE			20	1			0.00	20	1			SPARE	30
31	SPARE			20	1			0.00	20	1			SPARE	32
33	SPARE			20	1			0.00	20	1			SPARE	34
35	SPARE			20	1			0.00	20	1			SPARE	36
37	SPARE			30	1			0.00	30	1		6	1 SPD	38
39	SPARE			30	1			0.00	30	1				40
41	SPARE			30	1			0.00	30	1				42
TOTAL CONNECTED LOAD:				4.10	3.80	TOTAL =		8.90	KVA					
# ONE (1) OR TWO (2) DIGIT NUMBERS REFER TO CONDUIT & WIRE SCHEDULE ON THIS SHEET. 34 1-pole 20A breakers, 3 1-pole 30A breakers, 1 2-pole 30A breaker, 1 3-pole 30A breaker														

BOOSTER STATION LIGHTING PANEL (LP-BS) SCHEDULE

SCALE: NONE

PANEL SCHEDULE		DESIGNATION: LP-HSP LOCATION: HOGGATE HIGH SERVICE PUMP BUILDING VOLTAGE: 120/208 V AC PHASE: 3 PHASE, 4 WIRE				MAINS: 50 AMP MAIN CIRCUIT BREAKER BUS SIZE: 100 AMP PANEL MOUNTING: SURFACE ALL BREAKERS: 10000 A.I.C. (MINIMUM)								
OKT. NO.	LOAD DESCRIPTION	#	KVA	OKT. BKR.			KVA			OKT. BKR.	KVA	#	LOAD DESCRIPTION	OKT. NO.
				AMPS	POLE	A	B	C	AMPS					
1	CHEMICAL FEED PUMP NO.1	1	0.20	20	1	0.40			20	1	0.20	1	CHEMICAL FEED PUMP NO.2	2
3	CHEMICAL FEED PUMP NO.3	1	0.20	20	1		0.40		20	1	0.20	1	CHEMICAL FEED PUMP NO.4	4
5	HSP CONTROL PANEL (CP-HSP)	1	1.00	20	1			1.00	20	1			SPARE	6
7	CHEMICAL ROOM NO.1 RECEPTACLES	1	0.20	20	1		0.40		20	1	0.20	1	CHEMICAL ROOMS LIGHTING	8
9	CHEMICAL ROOM NO.2 RECEPTACLES	1	0.20	20	1		0.40		20	1	0.20	1	CHEMICAL BUILDING OUTDOOR LIGHTING	10
11	BLEACH TANK SCALE (WIT-3100)	1	0.10	20	1			0.20	20	1	0.10	1	PHOSPHATE TANK SCALE (WIT-3000)	12
13	HSP BUILDING RECEPTACLES	1	0.20	20	1		0.40		20	1	0.20	1	HSP BUILDING LIGHTING	14
15	EFFLUENT FLOW METER (FE/FT-1000)	1	0.10	20	1		0.40		20	1	0.30	1	SUMP PUMP RECEPTACLE	16
17	BLEACH ROOM EXHAUST FAN (EF-1B)	1	0.20	20	1			1.70	25	2	1.50	4	HSP MINISPLIT (SSAC-1)	18
19	PHOSPHATE ROOM EXHAUST FAN (EF-1A)	1	0.20	20	1		1.70				1.50			20
21	FINISHED WATER FLOW METER (FE/FT-2000)	1	0.10	20	1		2.50		30	2	2.40	4	HSP UNIT HEATER (EWUH-1)	22
23	DEDICATED RECEPTACLE FOR FUTURE EQUIPMENT	1		20	1			2.40			2.40			24
25	HEAT TRACING (GFEP BREAKER)	1	1.00	20	1		1.00		20	1			SPARE	26
27	SPARE			20	1			0.00	20	1			SPARE	28
29	SPARE			20	1			0.00	20	1			SPARE	30
31	SPARE			20	1		0.00		20	1			SPARE	32
33	SPARE			20	1		0.00		20	1			SPARE	34
35	SPARE			20	1			0.00	20	1			SPARE	36
37	SPARE			30	1		0.00		30	3		6	1 SPD	38
39	SPARE			30	1			0.00	30	1				40
41	SPARE			30	1			0.00	30	1				42
TOTAL CONNECTED LOAD:				3.90	3.70	TOTAL =		12.90	KVA					
# ONE (1) OR TWO (2) DIGIT NUMBERS REFER TO CONDUIT & WIRE SCHEDULE ON THIS SHEET. 32 1-pole 20A breakers, 1 2-pole 25A breaker, 3 1-pole 30A breakers, 1 2-pole 30A breaker, 1 3-pole 30A breaker														

HSP LIGHTING PANEL (LP-HSP) SCHEDULE

SCALE: NONE

CONDUIT & WIRE SCHEDULE:

- 1 3/4", #12, #12N, #12G
- 2 3/4", 2#12, #12N, #12G
- 3 3/4", #10, #10N, #10G
- 4 3/4", 2#10, #10N, #10G
- 5 1" C, 2#6, #6N, #10G
- 6 3/4", 3#10, #10G
- 7 2" C, 2#1/0, #1/0N, #6G

KEYED NOTES:

- 1 SEE PANELBOARD SPECIFICATION FOR SPD INFORMATION

For Viewing Purposes Only - Visit [www.wesslerengineering.com](http://www.wesslerengineering.com)

SCALE VERIFICATION BAR IS ONE INCH LONG ON ORIGINAL DRAWING	DRAWN BY	JLK	NO.	DATE	INITIALS	REVISION DESCRIPTIONS
	CHECKED BY	JAP				
	APPROVED BY	WCM				
	ISSUE DATE	FEBRUARY 2026				
	PROJECT NUMBER	703222-04-001				

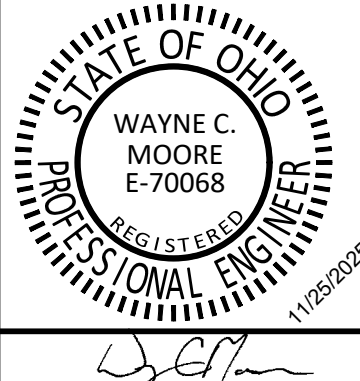

**W**  
**WESSLER**  
ENGINEERING  
*More than a Project™*

**WATER SYSTEM IMPROVEMENTS**

CONTRACT B NEW BOOSTER STATION AND WATER TREATMENT PLANT IMPROVEMENTS  
VILLAGE OF HOGGATE, OHIO

**ELECTRICAL SCHEDULES**

SHEET NO.  
**8E5**

PAGE NO.  
**50**

DDAGW-4113



Drawing: X:\Hoggate\_OH\703222\_Hoggate\_WTP\Contract B - Booster Station and WTP\DWG\Sheets\703222-EL-001.dwg | Layout: 8E5 | Plotter: 01/21/26 @ 03:05:37 | L:\S:\S:\S\By: jashk

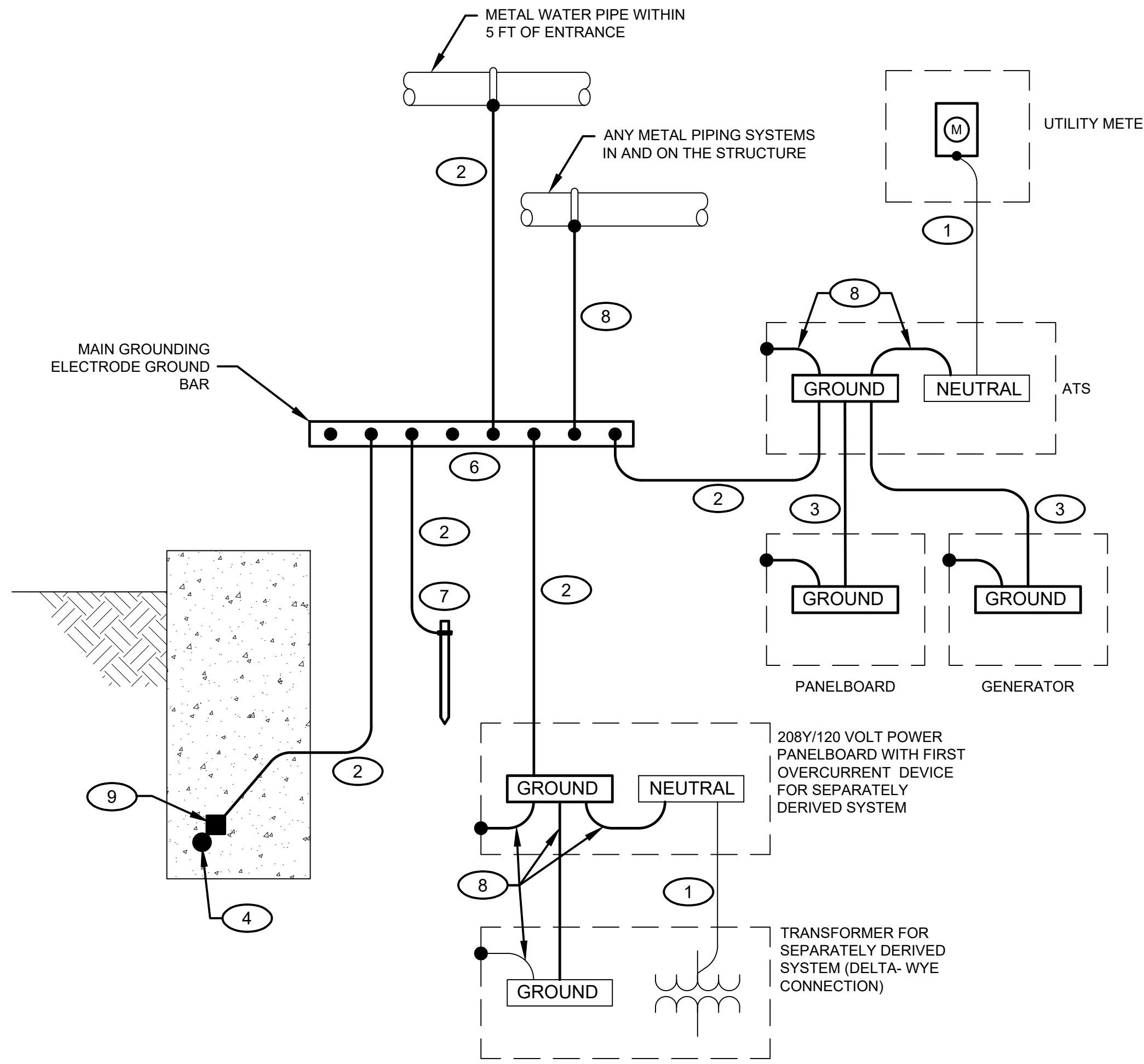

**GROUNDING SYSTEM DIAGRAM**  
SCALE: NONE

**KEYED NOTES**

1. INSTALL GROUNDED (NEUTRAL) CONDUCTOR SAME SIZE AS THE LARGEST PHASE CONDUCTOR.
2. INSTALL GROUNDING ELECTRODE CONDUCTOR, SIZED BASED ON NEC TABLE 250.66 USING THE SERVICE PHASE CONDUCTOR SIZE, BUT NOT SMALLER THAN 4 AWG.
3. INSTALL EQUIPMENT GROUNDING CONDUCTOR SIZED BASED ON NEC TABLE 250.122 USING THE FEEDER OVERCURRENT DEVICE SIZE.
4. INSTALL A CONCRETE-ENCASED GROUNDING ELECTRODE IN THE STRUCTURE FOUNDATION. LOCATE ELECTRODE WITH AT LEAST 3 INCHES OF CONCRETE COVER. USE EITHER OF THE FOLLOWING MATERIALS FOR THE ELECTRODE:  
BARE COPPER CABLE NOT SMALLER THAN THE GROUNDING ELECTRODE CONDUCTOR REQUIRED BY THE NEC AND NOT SMALLER THAN 4 AWG.  
BARE OR GALVANIZED REBARS THAT ARE MADE ELECTRICALLY CONTINUOUS USING COPPER JUMPERS NOT SMALLER THAN 1/2IN DIAMETER AND 20 FEET IN TOTAL LENGTH.
5. BOND EACH PERIMETER STRUCTURAL STEEL COLUMN TO THE CONCRETE-ENCASED MAIN GROUNDING ELECTRODE. USE COMPRESSION CONNECTORS THAT MEET IEEE 837 REQUIREMENTS OR USE EXOTHERMIC WELDS.
6. INSTALL A "MAIN GROUND ELECTRODE GROUND BAR" FOR SINGLE POINT GROUNDING. LOCATE AT AN ACCESSIBLE AND VISIBLE POINT NEAR THE SERVICE ENTRANCE EQUIPMENT. MAKE CONNECTIONS TO THE GROUND BAR USING TWO-HOLE COMPRESSION SPADE LUGS THAT MEET IEEE 837 REQUIREMENTS. LABEL EACH CONNECTION TO THE GROUND BAR. DETAIL ON THIS SHEET.
7. GROUND ROD/GRID. BOND THE GROUND ROD TO THE MAIN GROUNDING ELECTRODE GROUND BAR. AT THE UNDERGROUND CONNECTION USE A COMPRESSION CONNECTOR THAT MEETS IEEE 837 REQUIREMENTS OR USE AN EXOTHERMIC WELD.
8. INSTALL BONDING CONDUCTOR THAT IS SIZED BASED ON NEC TABLE 250.102(C)(1).
9. INSTALL IRREVERSIBLE COMPRESSION CONNECTOR WITH TAMPER-PROOF HARDWARE OR INSTALL EXOTHERMIC WELD.

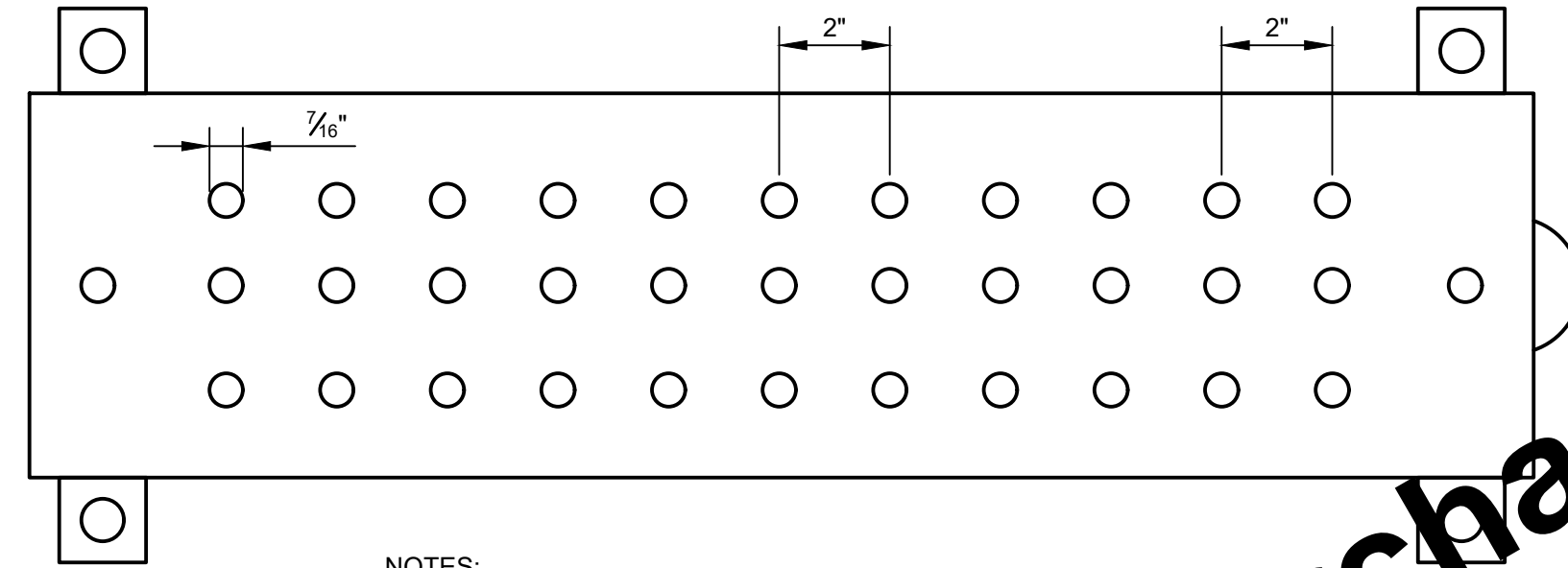

**NOTES:**

1. PROVIDE 1/4" DEEP X 4" HIGH X 2'-0" LONG COPPER GROUND BUS BAR WITH INSULATED WALL BRACKET ASSEMBLY. ERICO EGB-A-14-1/4" OR APPROVED EQUAL AS SPECIFIED. PRE DRILLED NEMA 1/4" HOLES AS INDICATED. PROVIDE BRASS METAL NAME TAGS ON EACH GROUNDING CABLE INDICATING IDENTIFYING TAG OF EQUIPMENT BEING GROUNDED. TERMINATE GROUNDING CABLE WITH NEMA TWO-HOLE BOLTED LUG.
2. REFER TO EQUIPMENT PLANS FOR GROUNDING CABLE SIZES, QUANTITIES AND EQUIPMENT DESCRIPTIONS.

**GROUND BUS BAR DETAIL**  
SCALE: NONE

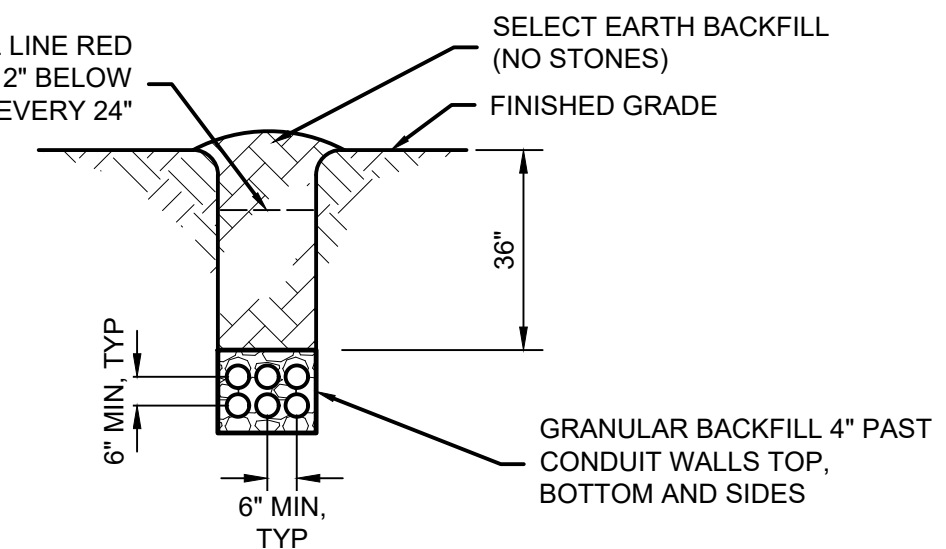

**CONDUIT TRENCH**  
SCALE: NONE

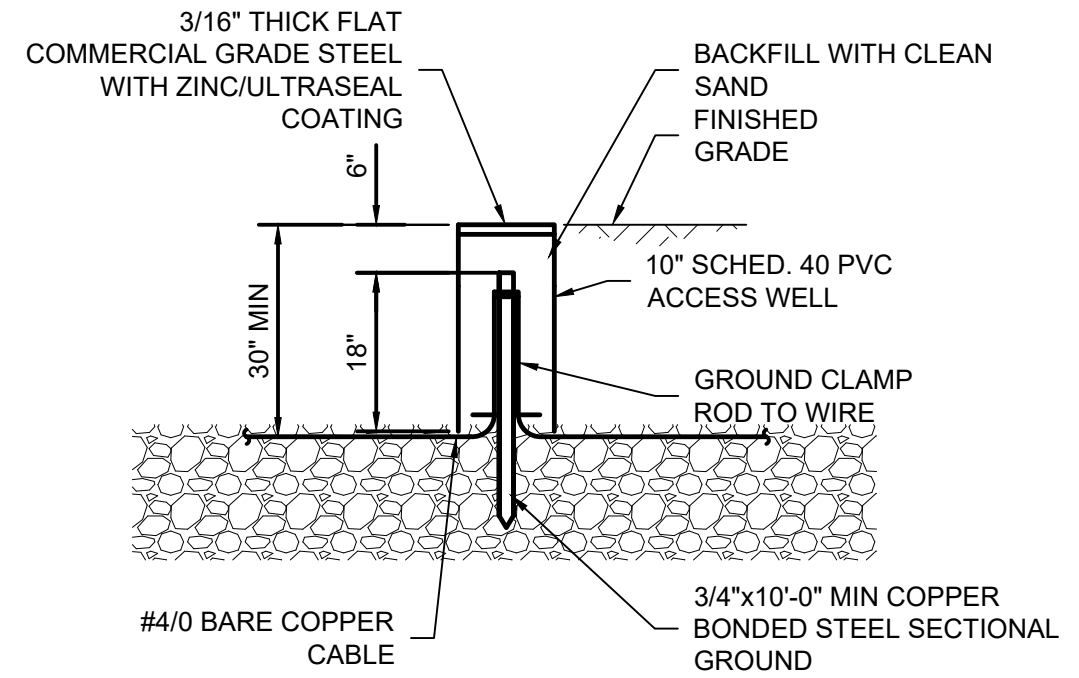

**NOTES:**

1. REFER TO JOB SPECIFICATION FOR MINIMUM SYSTEM RESISTANCE TO GROUND. IF THE RESISTANCE CANNOT BE MET WITH SINGLE 10'-0" RODS, ADD ADDITIONAL SECTIONS TO RODS OR ADD NEW RODS AS REQUIRED, SPACED 6'-0" TO 10'-0" FROM EXISTING RODS.

**ELECTRICAL INSTALLATION AND GROUND ROD ASSEMBLY**  
SCALE: NONE

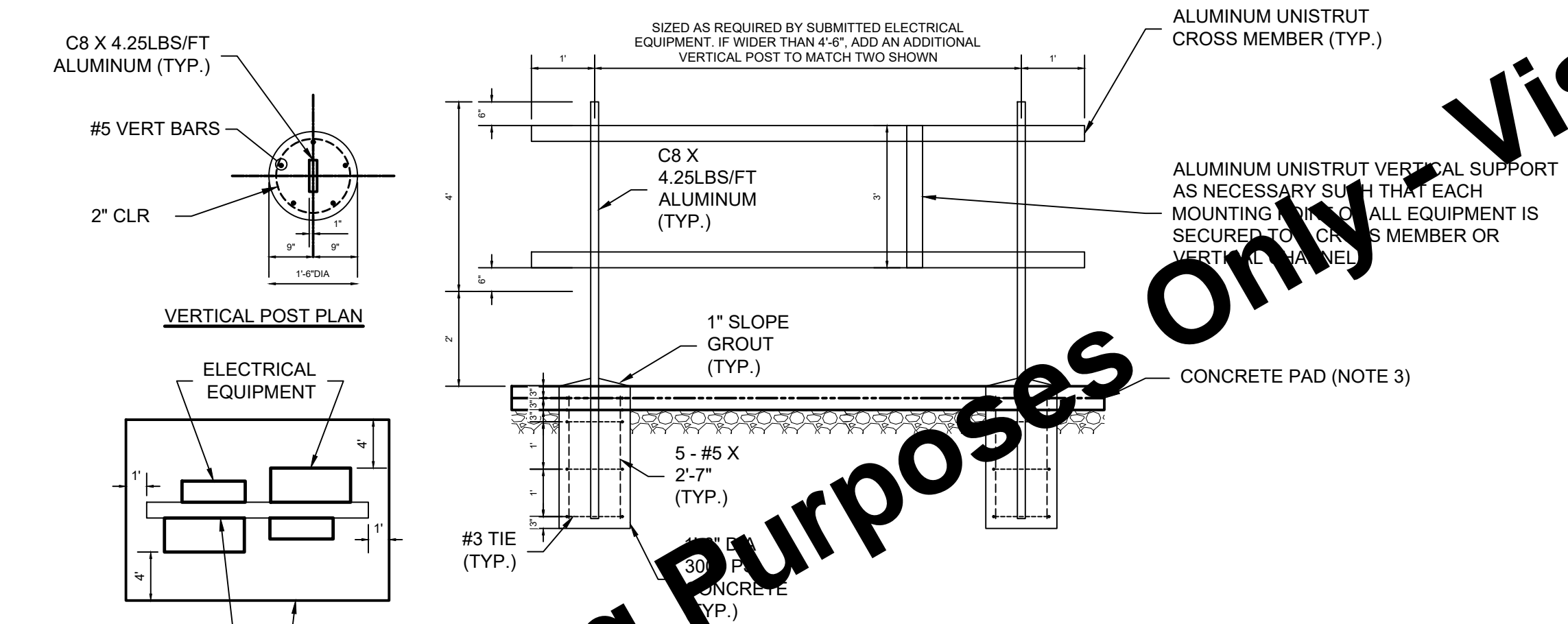

**ELECTRICAL EQUIPMENT RACK**  
SCALE: NONE

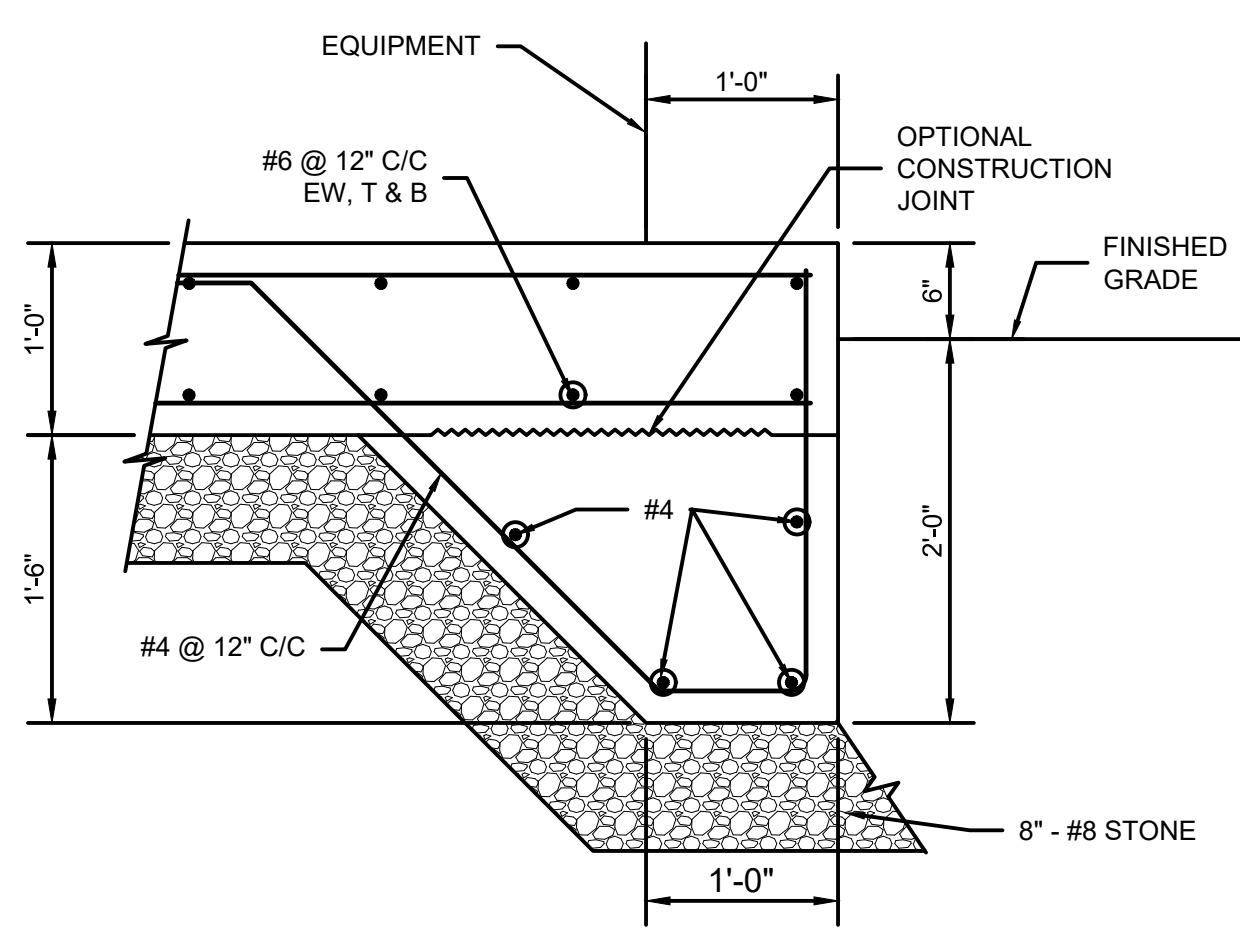

**GENERATOR PAD**  
SCALE: 1" = 1'-0"

TYPE	WATTS	LAMP	TYPE LUMINAIRE	MANUFACTURER
A	64	LED	CEILING MOUNTED, WET LOCATION RATED, LED LIGHT FIXTURE, 120-277 MVOLT, FROSTED POLYCARBONATE LENS, MEDIUM DISTRIBUTION, 80CRI, 6000 LUMENS OR GREATER WITH 4% UPLIGHT, 4000K COLOR TEMPERATURE.	HOLOPHANE EVT4 SERIES OR EQUAL.
B/BE	72	LED	WALLPACK FULL CUTOFF LED LIGHT FIXTURE, 120-277 MVOLT, DIE-CAST ALUMINUM CORROSION-RESISTANT HOUSING, 5600 LUMENS, 4000K COLOR TEMPERATURE, TYPE IV MEDIUM DISTRIBUTION, 80 CRI, BLACK HOUSING. WITH AO (ADJUSTABLE OUTPUT) OPTION. "BE" DENOTES INCLUSION OF EMERGENCY BATTERY BACKUP.	HOLOPHANE HLWPC2 OR EQUAL.
C	25	LED	CANOPY MOUNT, LED, 120-277V MVOLT, 3000 LUMENS, DIE-CAST ALUMINUM HOUSING, IMPACT-RESISTANT FROSTED ACRYLIC LENS, TYPE V DISTRIBUTION, 80 CRI, 4000K, WITH EMERGENCY BATTERY BACKUP	HOLOPHANE PPSQL2 LED OR EQUAL
D	42	LED	RECESSED CEILING-MOUNTED LED PANEL, 2X4, DAMP LOCATION RATED, 120-277 MVOLT, BACK-LIT DESIGN, SATIN WHITE ACRYLIC LENS, 5000 LUMENS NOMINAL, 80 CRI MINIMUM, 4000K COLOR TEMPERATURE, 0-10V DIMMING.	LITHONIA CPX LED PANEL OR EQUAL
E	3	LED	EMERGENCY LIGHT, TWO HEAD LED, WET LOCATION RATED, WALL MOUNTED, TEST SWITCH, STATUS INDICATOR, 90 MIN OF ILLUMINATION.	HOLOPHANE DM30 WL LED OR EQUAL.
XE	3	LED	LED EXIT SIGN AND EMERGENCY LIGHT COMBO, 90 MIN OF ILLUMINATION, SUITABLE FOR WET LOCATIONS.	HOLOPHANE DLTLC OR EQUAL.

**LIGHTING FIXTURE SCHEDULE**  
SCALE: NONE

For Viewing Purposes Only Visit [www.wesslerengineering.com](http://www.wesslerengineering.com) to Purchase

SCALE VERIFICATION	DRAWN BY	NO.	DATE	INITIALS	REVISION DESCRIPTIONS
BAR IS ONE INCH LONG ON ORIGINAL DRAWING	JLK				
	JAP				
	WCM				
	ISSUE DATE				
	FEBRUARY 2026				
	PROJECT NUMBER				
	703222-04-001				

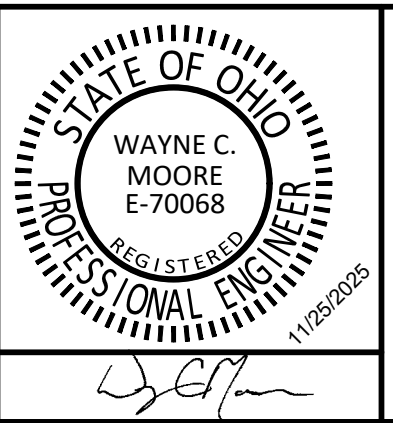

<b>WATER SYSTEM IMPROVEMENTS</b>	SHEET NO.
CONTRACT B NEW BOOSTER STATION AND WATER TREATMENT PLANT IMPROVEMENTS VILLAGE OF HOLGATE, OHIO	<b>8E6</b>
<b>ELECTRICAL DETAILS</b>	PAGE NO.
	<b>51</b>
	DDAGW-4113

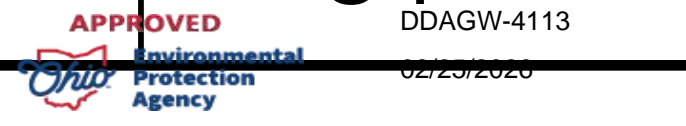

Drawing: X:\Hologic\041703222\Hologic\WTP\DWG\Sheets\703222-EL-001.dwg | Layout: 8E6 | Plotter: 01/21/26 @ 03:05:40 | L:\s\wcm\jask

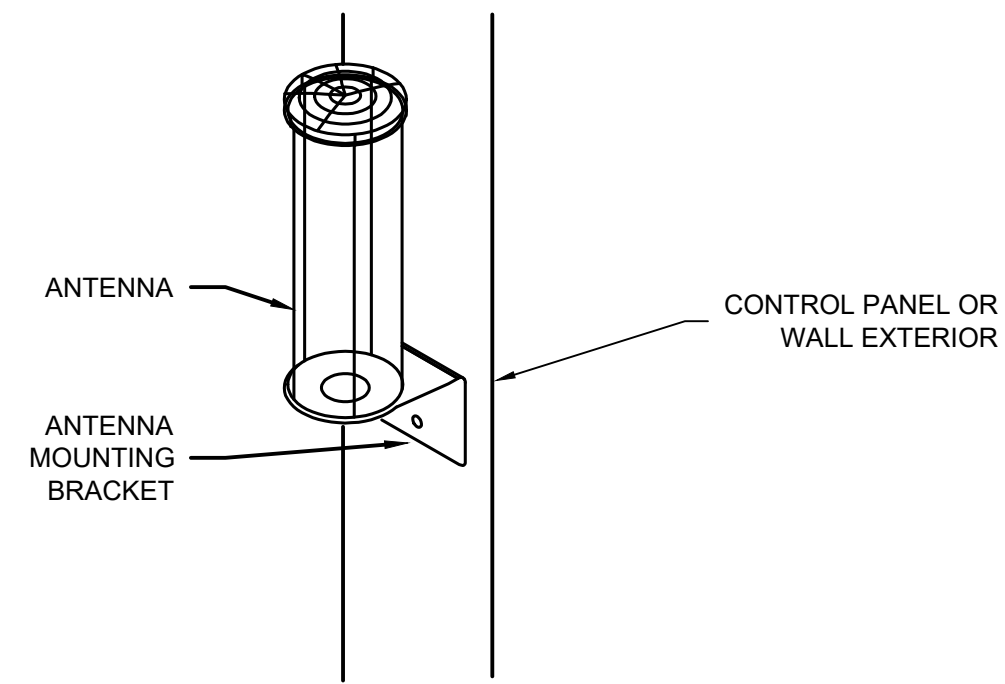

**CELLULAR ANTENNA DETAIL**  
SCALE: NONE

- NOTES:**
1. ALL HARDWARE ANCHORS, BOLTS, WASHERS AND ALL OTHER HARDWARE TO BE STAINLESS STEEL, 1/4" DIA MIN.
  2. MOUNT ALUMINUM CONDUIT TO ANTENNA HEIGHT USING STAINLESS STEEL HARDWARE.
  3. CONDUIT AND GROUND WIRE WILL BE RUN FROM INSIDE OF THE TOWER.

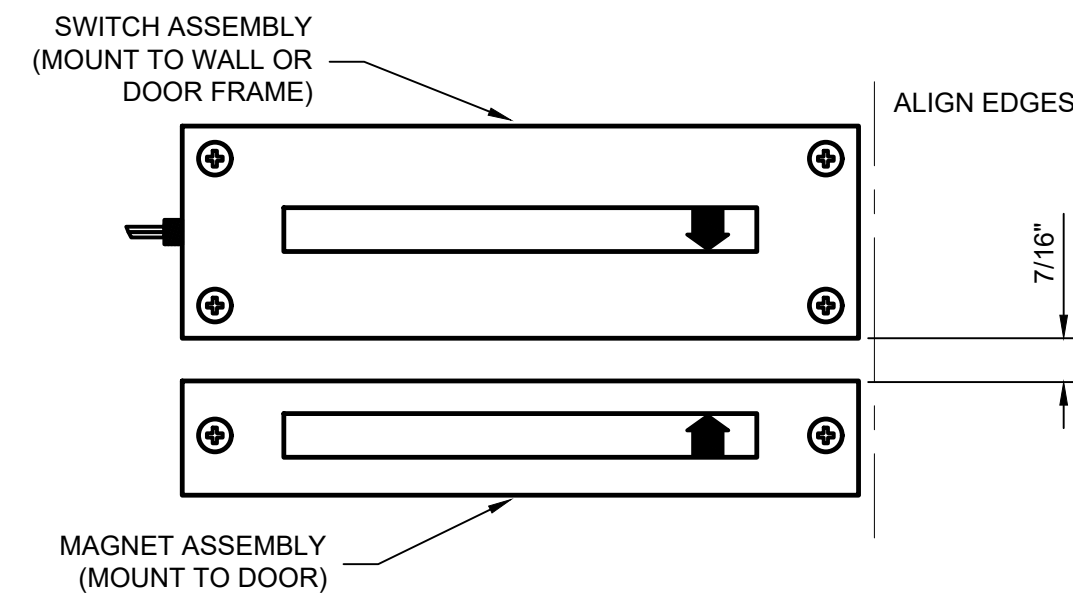

**INTRUSION SWITCH INSTALLATION**  
SCALE: NONE

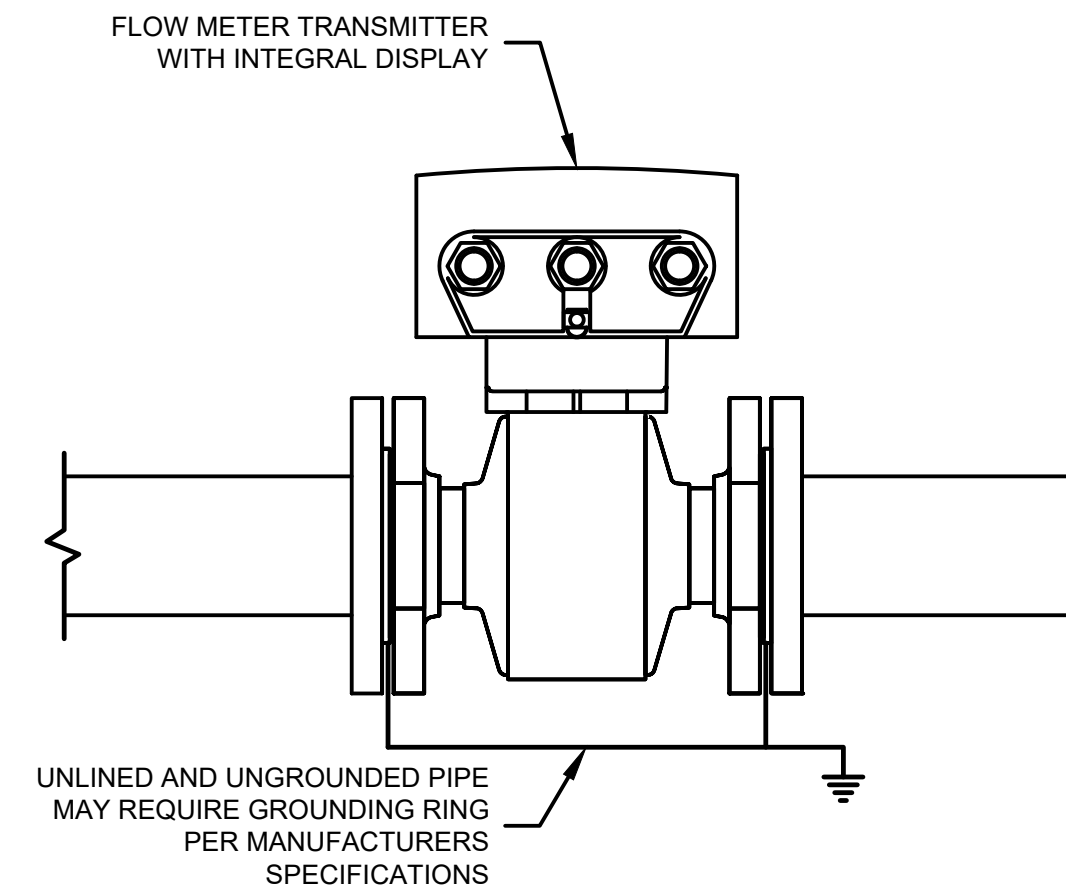

**FLOW METER MOUNTING - INTEGRAL TRANSMITTER**  
SCALE: NONE

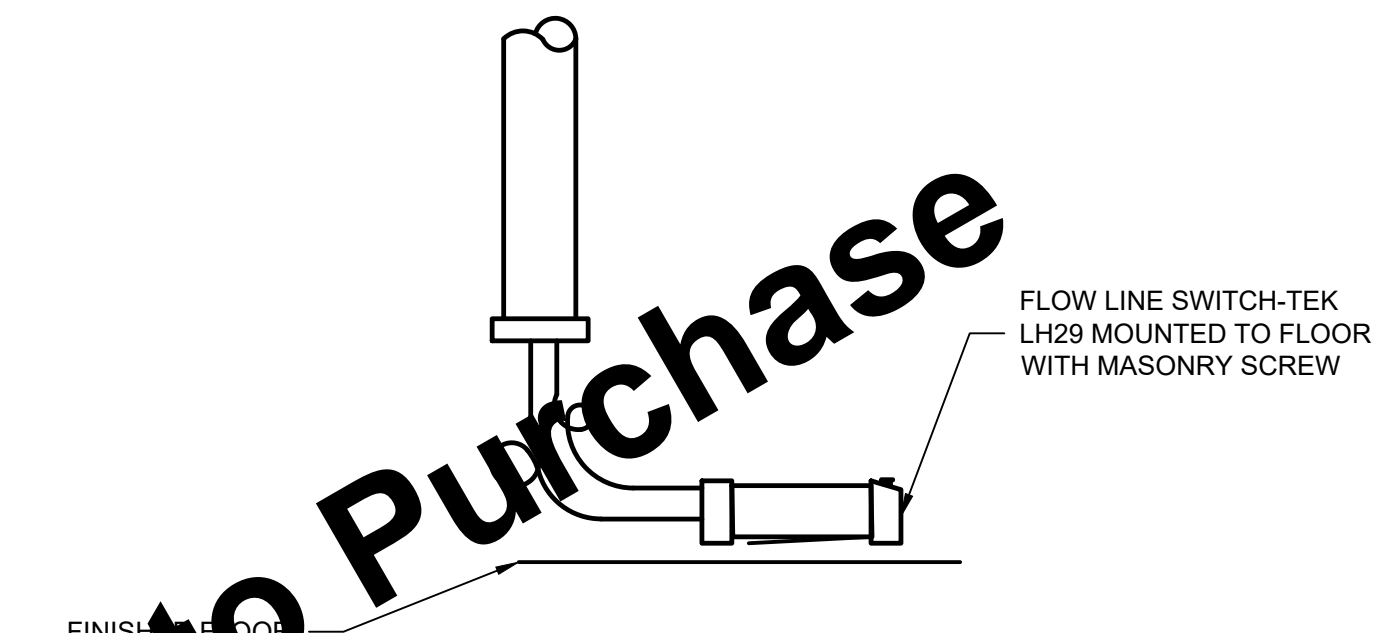

**LEAK DETECTION SWITCH FLOOR MOUNTING**  
SCALE: NONE

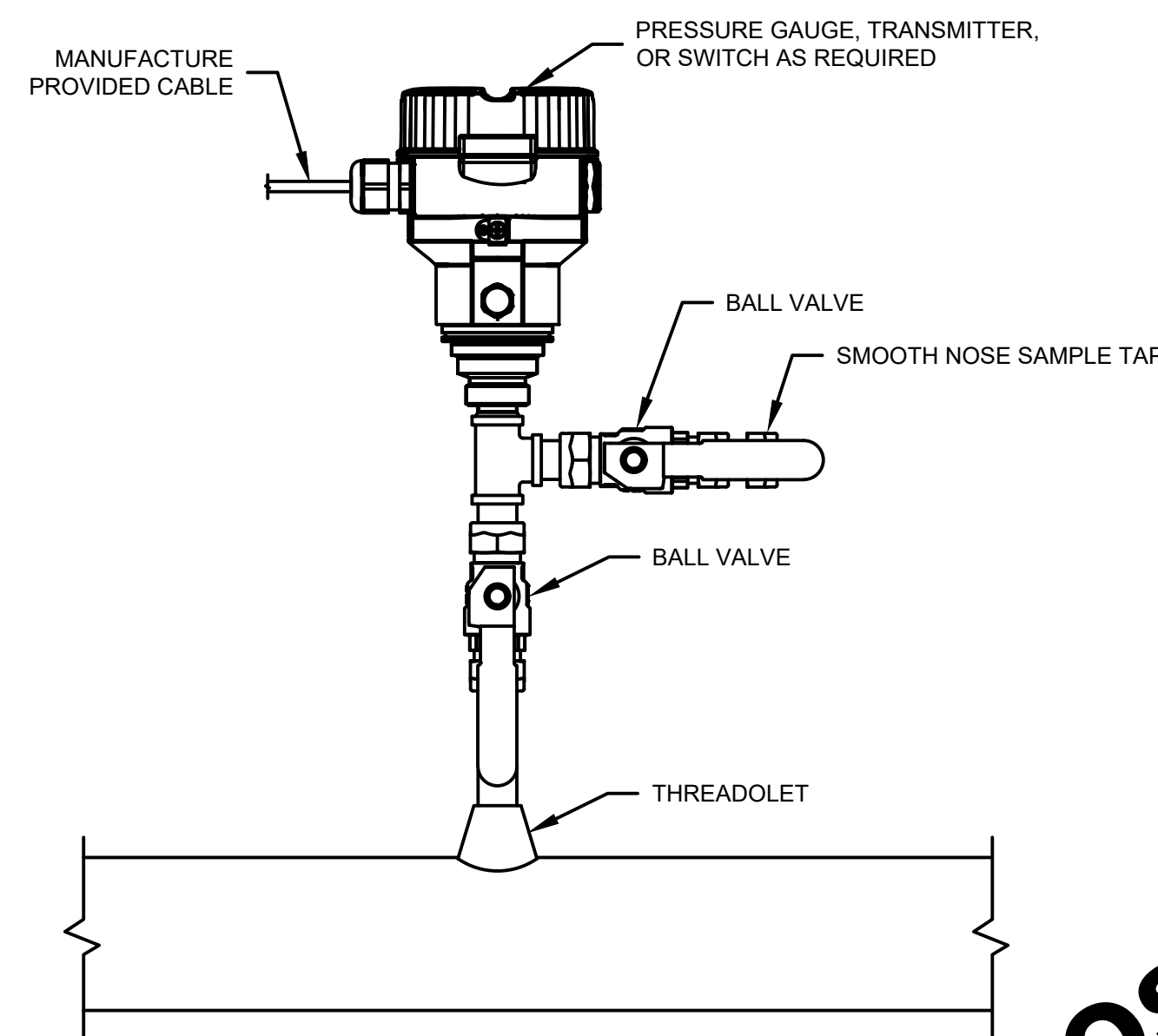

**PRESSURE TRANSMITTER MOUNTING**  
SCALE: NONE

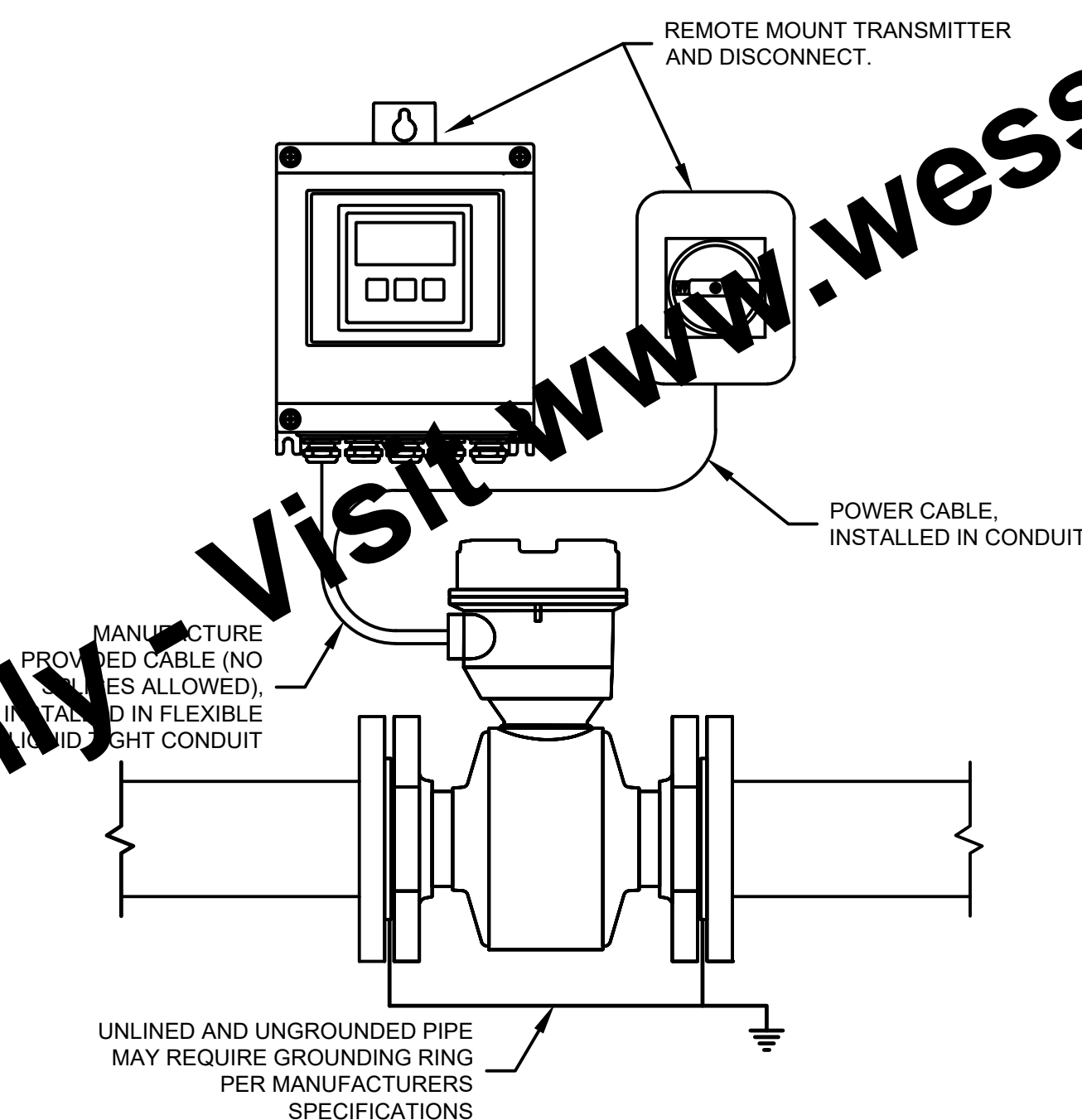

**FLOW METER MOUNTING - REMOTE TRANSMITTER**  
SCALE: NONE

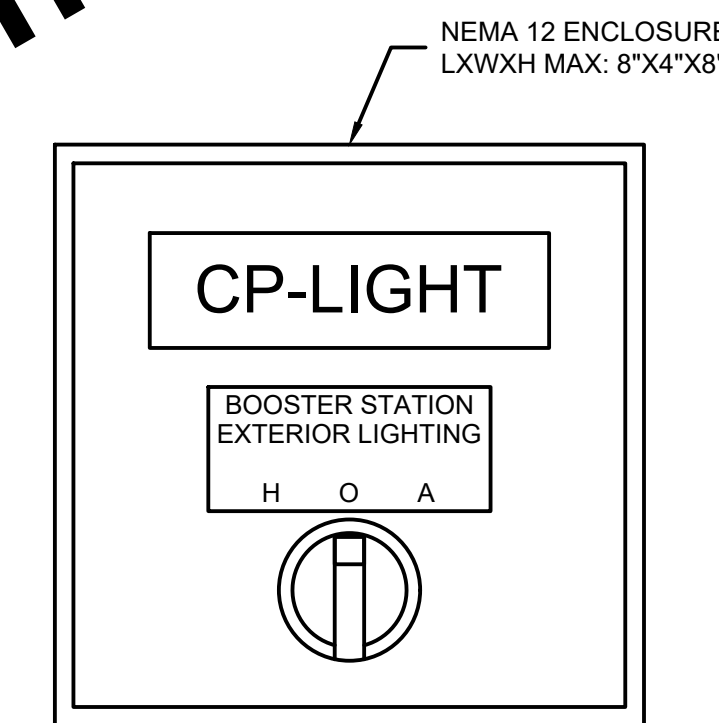

**LIGHTING CONTROL PANEL AND WIRING DIAGRAM (CP-LIGHT)**  
SCALE: NONE

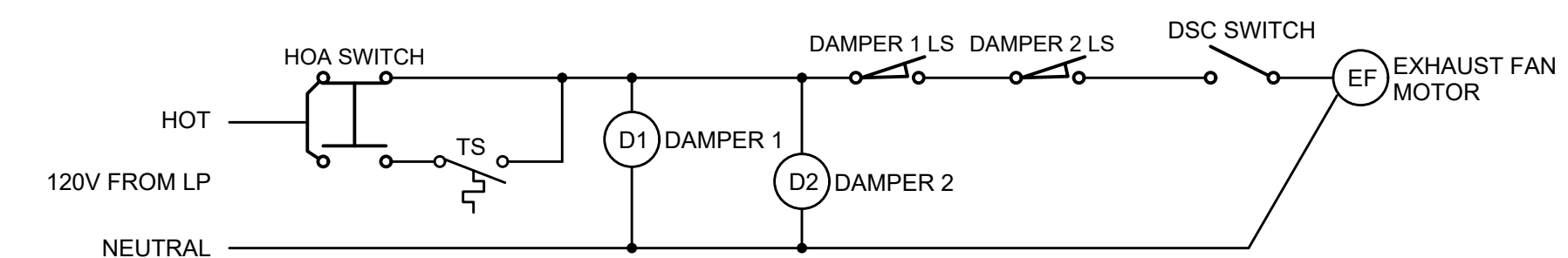

**EXHAUST FAN WIRING SCHEMATIC**  
SCALE: NONE

For Viewing Purposes Only - Visit [www.wesslerengineering.com](http://www.wesslerengineering.com)

SCALE VERIFICATION	DRAWN BY	NO.	DATE	INITIALS	REVISION DESCRIPTIONS
BAR IS ONE INCH LONG ON ORIGINAL DRAWING 	BNH				
	BDP				
	BNH				
	ISSUE DATE				
	PROJECT NUMBER				
	703222-04-001				

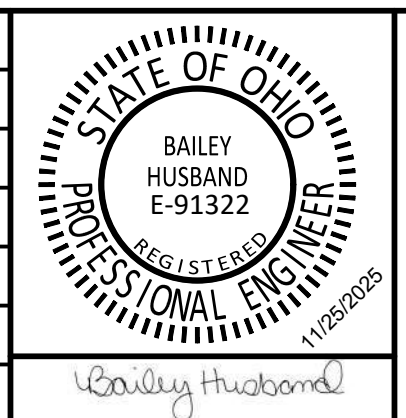

<b>WATER SYSTEM IMPROVEMENTS</b> CONTRACT B NEW BOOSTER STATION AND WATER TREATMENT PLANT IMPROVEMENTS VILLAGE OF HOLGATE, OHIO
<b>CONTROL DETAILS</b>

SHEET NO.	<b>8E7</b>
PAGE NO.	<b>52</b>
DDAGW-4113	



**VALVE SYMBOLS**

	ECCENTRIC PLUG		FLOW CONTROL VALVE
	THREE - WAY		BALL CHECK
	BUTTERFLY		SWING CHECK
	BALL		SPLIT DISC CHECK
	GLOBE		REGULATED SIDE PRESSURE CONTROL
	PRESSURE RELIEF		PINCH
	AIR RELEASE AND VACUUM RELIEF		DIAPHRAGM
	GATE		NEEDLE
	KNIFE GATE		CALIBRATED BALANCE
	CONSTANT VOLUME FLOW REGULATOR		SOLENOID

**GATE SYMBOLS**

	SLUICE GATE		SLIDE GATE		FLAP GATE
	WEIR GATE		STOP GATE		WEIR AND STOP GATE

**VALVE AND GATE POWER ACTUATOR SYMBOLS**

	ELECTRIC MOTOR		HYDRAULIC WITH SOLENOID
	ELECTRIC MOTOR WITH POSITIONER		PNEUMATIC WITH POSITIONER
	HYDRAULIC WITH POSITIONER		PNEUMATIC WITH SOLENOID

XX: FC = FAIL CLOSED  
 FIP = FAIL INTERMEDIATE POSITION  
 FIP = FAIL TO LAST POSITION  
 FO = FAIL OPEN

NOTE: XX = FAIL POSITION ON LOSS OF PRIMARY POWER (PNEUMATIC OR ELECTRICAL)

**FLOW ELEMENTS SYMBOLS**

	WEIR PLATE		CLAMP ON ULTRASONIC FLOWMETER
	PARSHALL FLUME		MAGNETIC FLOWMETER
	ROTAMETER		VENTURI OR FLOW TUBE
	PROPELLER OR TURBINE METER		AREA VELOCITY FLOWMETER
	ORIFICE METER		

**MISCELLANEOUS SYMBOLS**

	ORTHO PHOSPHATE ELEMENT		SUBMERSIBLE MIXER
	PROBE		AIR COMPRESSOR
	ELECTRIC MOTOR		FLOATING MIXER
	MANUAL SAMPLE PORT		FLAME TRAP AND THERMAL SHUTOFF ASSEMBLY
	AUTOMATIC DRAIN		FLOATING DECANTER
	BLIND FLANGE OR CLEAN OUT		TEMPERATURE GAUGE
	AIR GAP		PRESSURE GAUGE
	STRAINER		PRESSURE TRANSMITTER
	FLUSHING WATER CONNECTION		LEVEL SWITCH
	SEAL WATER CONNECTION		
	DETECTOR		
	AUTOMATIC SAMPLER		
	DIFFUSER		
	BUBBLER LEVEL ELEMENT		
	VENT		
	RUPTURE DISK		
	ANNULAR SEAL		
	FLOW STRAIGHTENING VANE		
	CALIBRATION CHAMBER		
	DENSITY METER X: N - NUCLEAR O - OPTICAL U - ULTRASONIC		
	SELF CONTAINED AIR SUPPLY		
	PURGE SET X: W = WATER A = AIR		

**LEVEL ELEMENTS SYMBOLS**

	SUBMERSIBLE PRESSURE		NON-CONTACT RADAR
	ULTRASONIC		CAPACITANCE FLOAT STICK
	FLOAT		

**PUMP AND COMPRESSOR SYMBOLS**

	SUBMERSIBLE PUMP		COMPRESSOR (PISTON)
	CENTRIFUGAL BLOWER		CHEMICAL FEED PUMP
	CENTRIFUGAL PUMP (DRY)		PLUNGER PUMP
	VERTICAL TURBINE PUMP		DIAPHRAGM PUMP
	PROGRESSING CAVITY PUMP		PERISTALTIC PUMP
	LOBE PUMP, BLOWER OR COMPRESSOR (POSITIVE DISPLACEMENT)		

**FLOW STREAM IDENTIFIERS**

SEE PROCESS - MECHANICAL LEGEND

**INPUTS AND OUTPUTS TO PLC OR DISTRIBUTED CONTROL**

	ANALOG INPUT		ANALOG OUTPUT
	PULSE INPUT		PULSE OUTPUT
	DIGITAL INPUT		DIGITAL OUTPUT

NOTE:  
 X = TOTAL NUMBER OF SIGNALS WHERE MORE THAN ONE SIGNAL IS REQUIRED. IF QUANTITY IS NOT SHOWN THEN ONE SIGNAL IS REQUIRED.

**GENERAL NOTE:**

1. THIS IS A STANDARD LEGEND. NOT ALL THE INFORMATION SHOWN ON THIS LEGEND IS USED IN THESE CONTRACT DRAWINGS.

Drawing: X:Holgate\_OH\_703222\_Holgate WTP/Contract B - Booster Station and WTP/DWS/Sheets/703222-CD.dwg | Layout: W1 | Plotter: 01/21/26 @ 02:40:19 | LastSavedBy: BaileyH

For Viewing Purposes Only - Visit [www.wesslerengineering.com](http://www.wesslerengineering.com) to Purchase

SCALE VERIFICATION  BAR IS ONE INCH LONG ON ORIGINAL DRAWING 	DRAWN BY	BNH	NO.	DATE	INITIALS	REVISION DESCRIPTIONS
	CHECKED BY	BDP				
	APPROVED BY	BNH				
	ISSUE DATE	FEBRUARY 2026				
	PROJECT NUMBER	703222-04-001				

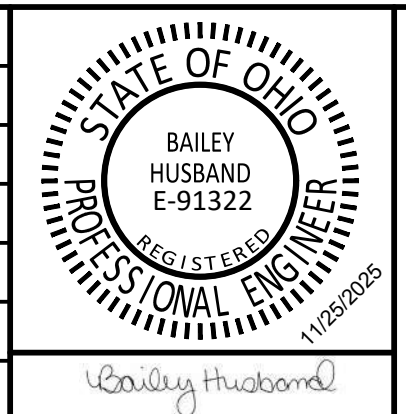

<b>WATER SYSTEM IMPROVEMENTS</b>
CONTRACT B NEW BOOSTER STATION AND WATER TREATMENT PLANT IMPROVEMENTS VILLAGE OF HOLGATE, OHIO
<b>PROCESS AND INSTRUMENTATION LEGEND</b>

SHEET NO. <b>9N1</b>
PAGE NO. <b>53</b>
DDAGW-4113



02/20/2026

For Viewing Purposes Only - Visit [www.wesslerengineering.com](http://www.wesslerengineering.com) to Purchase

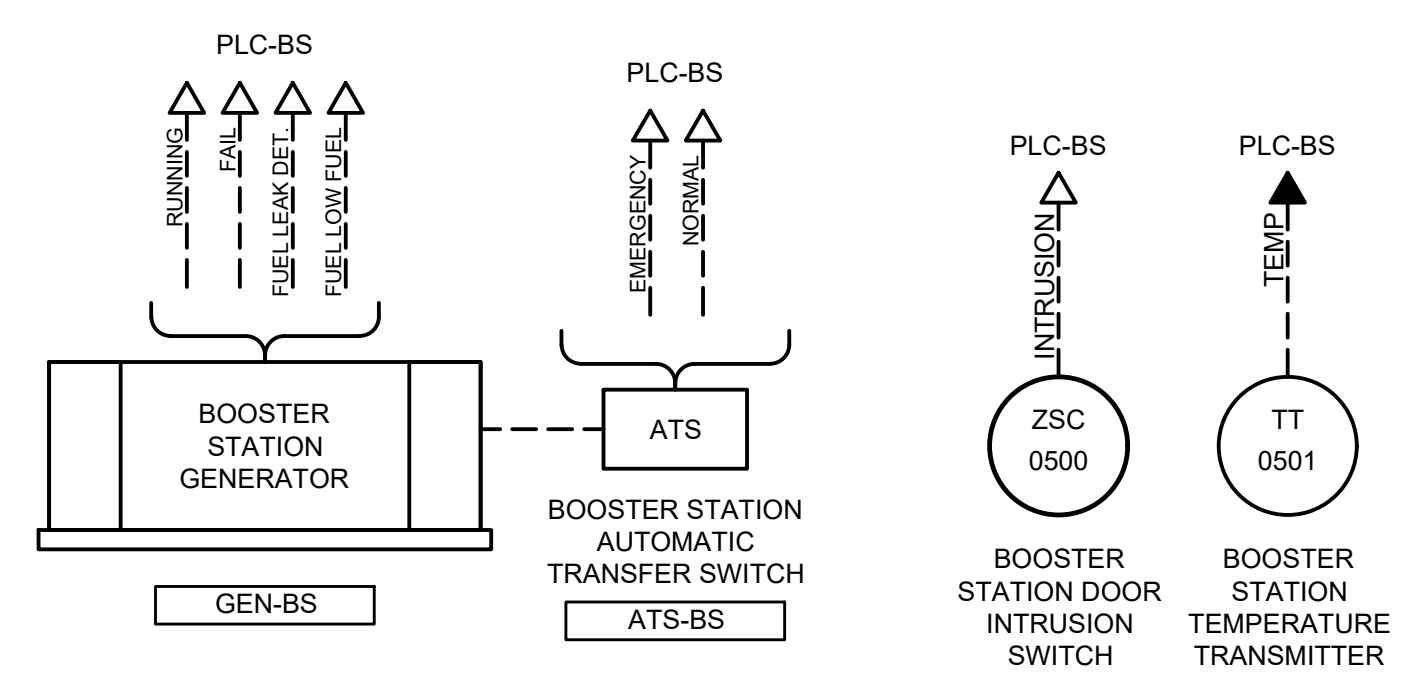
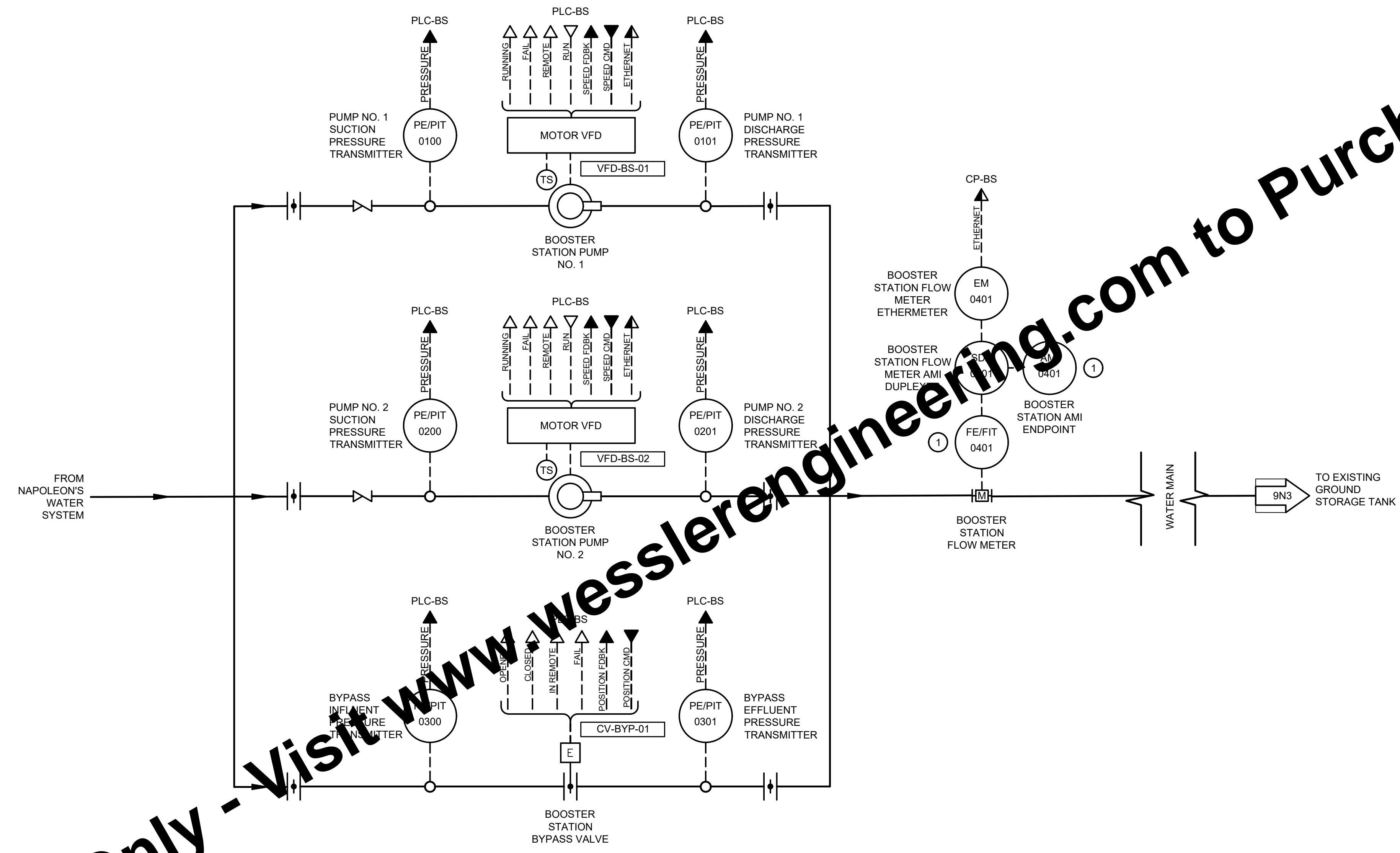

**KEYED NOTES:**  
 ① PROVIDED BY NAPOLEON

Drawing: X:\Hogale\_Oh\703222\_Hogale WTP\Contract B - Booster Station and WTP\DWG\Sheets\703222-PC-CD.dwg | Layout: 01/21/26 @ 02:40:22 | LastSavedBy: BaileyH

SCALE VERIFICATION	DRAWN BY	NO.	DATE	INITIALS	REVISION DESCRIPTIONS
BAR IS ONE INCH LONG ON ORIGINAL DRAWING	CHECKED BY	BNH			
	APPROVED BY	BDP			
	ISSUE DATE	BNH			
	FEBRUARY 2026				
	PROJECT NUMBER				
	703222-04-001				

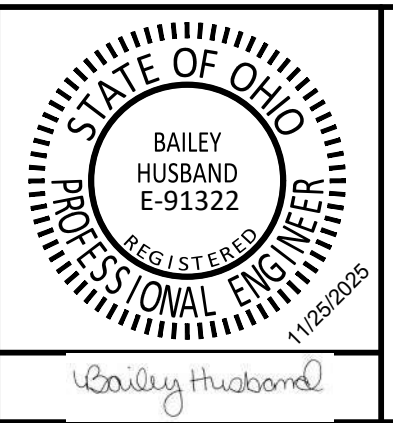

**WATER SYSTEM IMPROVEMENTS**

CONTRACT B NEW BOOSTER STATION AND WATER TREATMENT PLANT IMPROVEMENTS  
 VILLAGE OF HOLGATE, OHIO

**BOOSTER STATION PROCESS AND INSTRUMENTATION DIAGRAM**

SHEET NO.	9N2
PAGE NO.	54
DDAGW-4113	

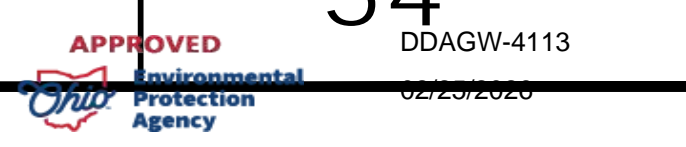

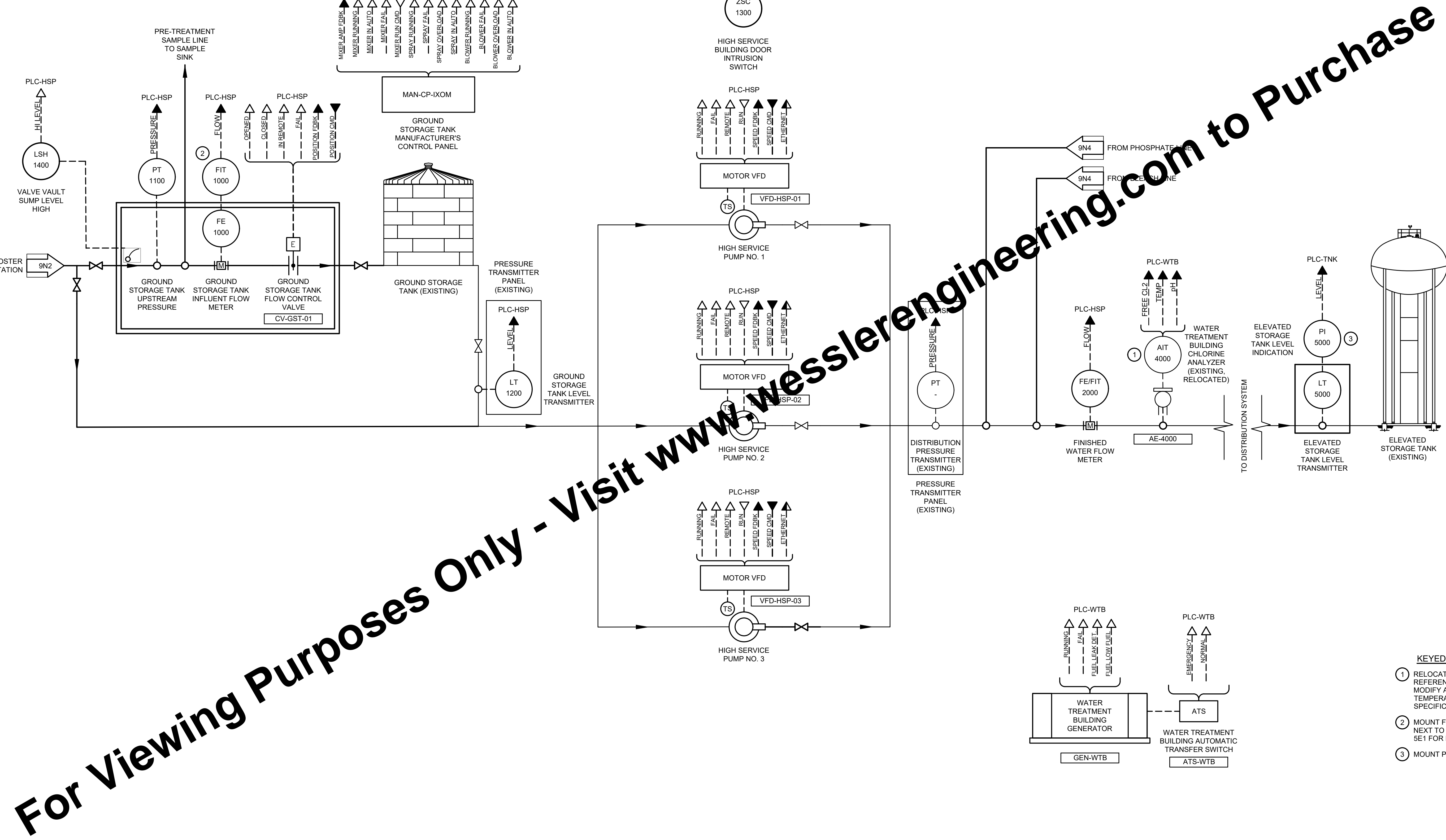

For Viewing Purposes Only - Visit [www.wesslerengineering.com](http://www.wesslerengineering.com) to Purchase

- KEYED NOTES:**
- RELOCATE EXISTING CHLORINE ANALYZER. REFERENCE SHEET 4E1 FOR NEW LOCATION. MODIFY ANALYZER TO INCLUDE pH AND TEMPERATURE MEASUREMENT. REFERENCE SPECIFICATION 13420 FOR MORE DETAILS.
  - MOUNT FIT-1000 IN A NEMA 4X ENCLOSURE NEXT TO MAN-CP-IXOM. REFERENCE SHEET 5E1 FOR LOCATION.
  - MOUNT PI-5000 IN CP-TNK.

SCALE VERIFICATION	DRAWN BY	NO.	DATE	INITIALS	REVISION DESCRIPTIONS
BAR IS ONE INCH LONG ON ORIGINAL DRAWING	BNH				
	CHECKED BY				
	BDP				
	APPROVED BY				
	BNH				
	ISSUE DATE				
	FEBRUARY 2026				
	PROJECT NUMBER				
	703222-04-001				

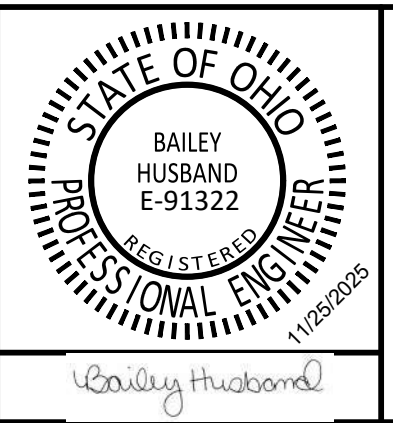

**WATER SYSTEM IMPROVEMENTS**

CONTRACT B NEW BOOSTER STATION AND WATER TREATMENT PLANT IMPROVEMENTS  
VILLAGE OF HOLGATE, OHIO

**HSP AND TANK PROCESS AND INSTRUMENTATION DIAGRAM**

SHEET NO.  
**9N3**

PAGE NO.  
**55**

DDAGW-4113  
02/26/2026

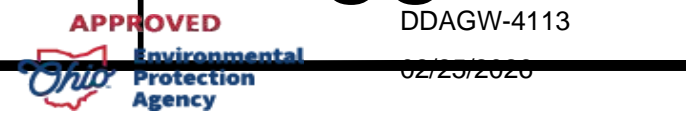

Drawing: X:\Holgate\_OH\703222\_Holgate WTP\Contract B - Booster Station and WTP\DWG\Sheets\703222-04-001.dwg | Layout: N3 | Plotted: 01/21/26 @ 02:40:25 | Last Saved By: BaileyH

For Viewing Purposes Only - Visit [www.wesslerengineering.com](http://www.wesslerengineering.com) to Purchase

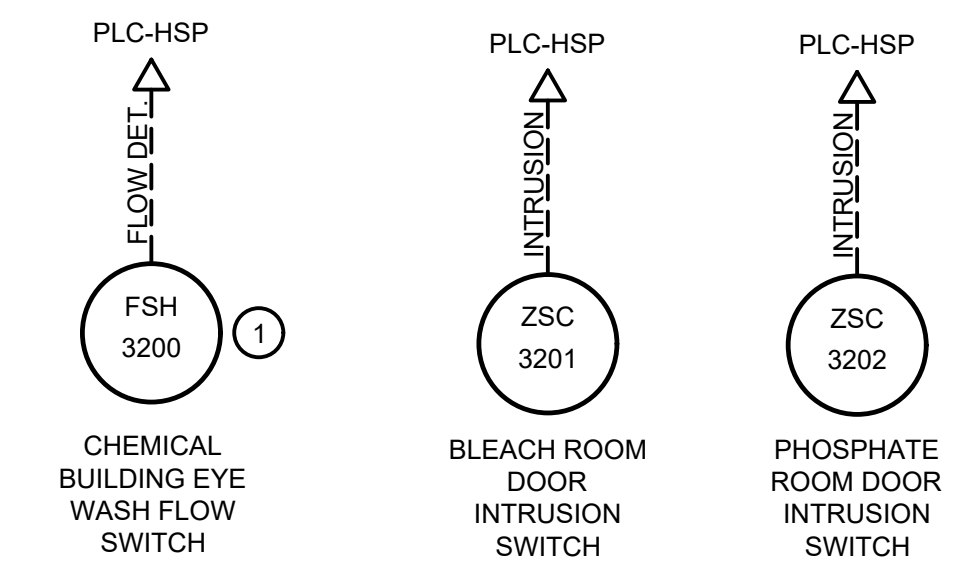
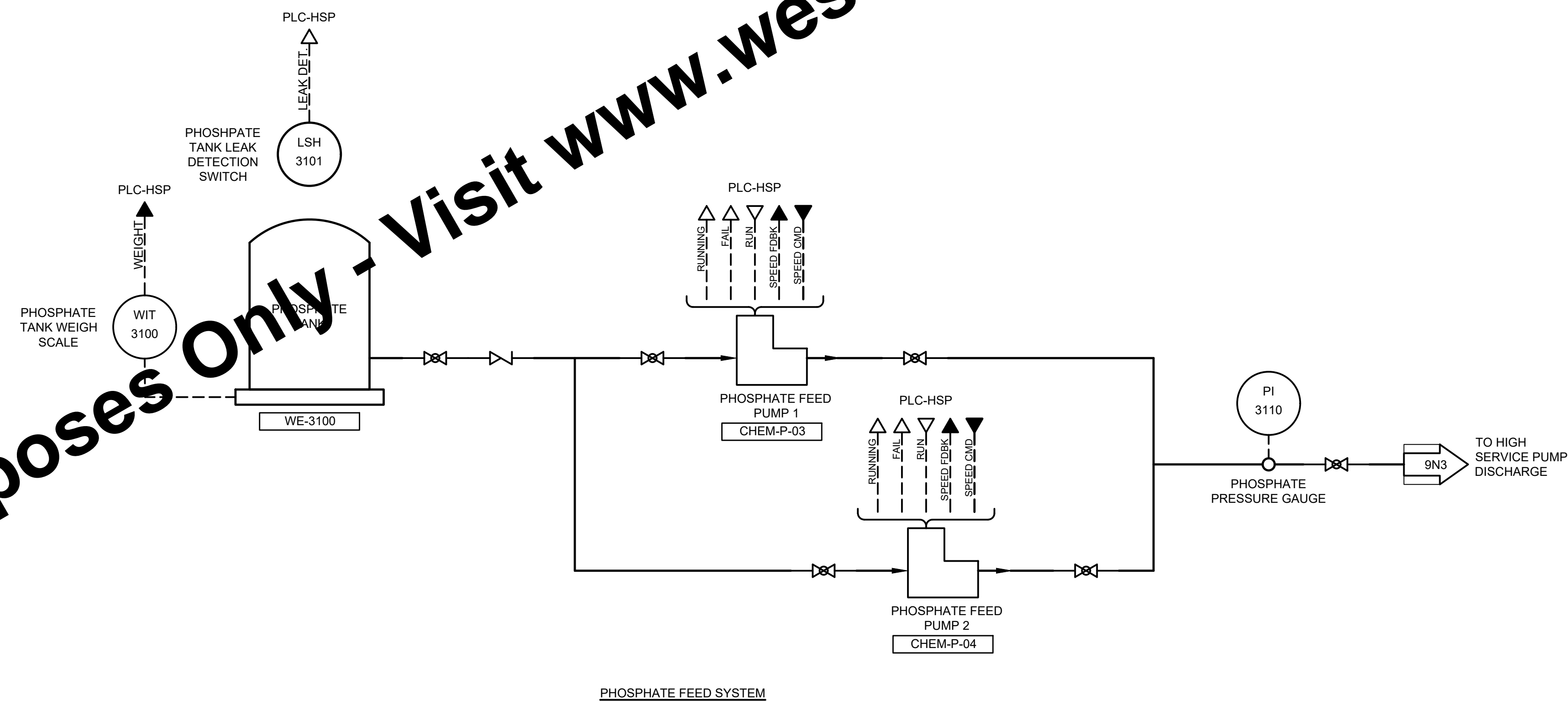
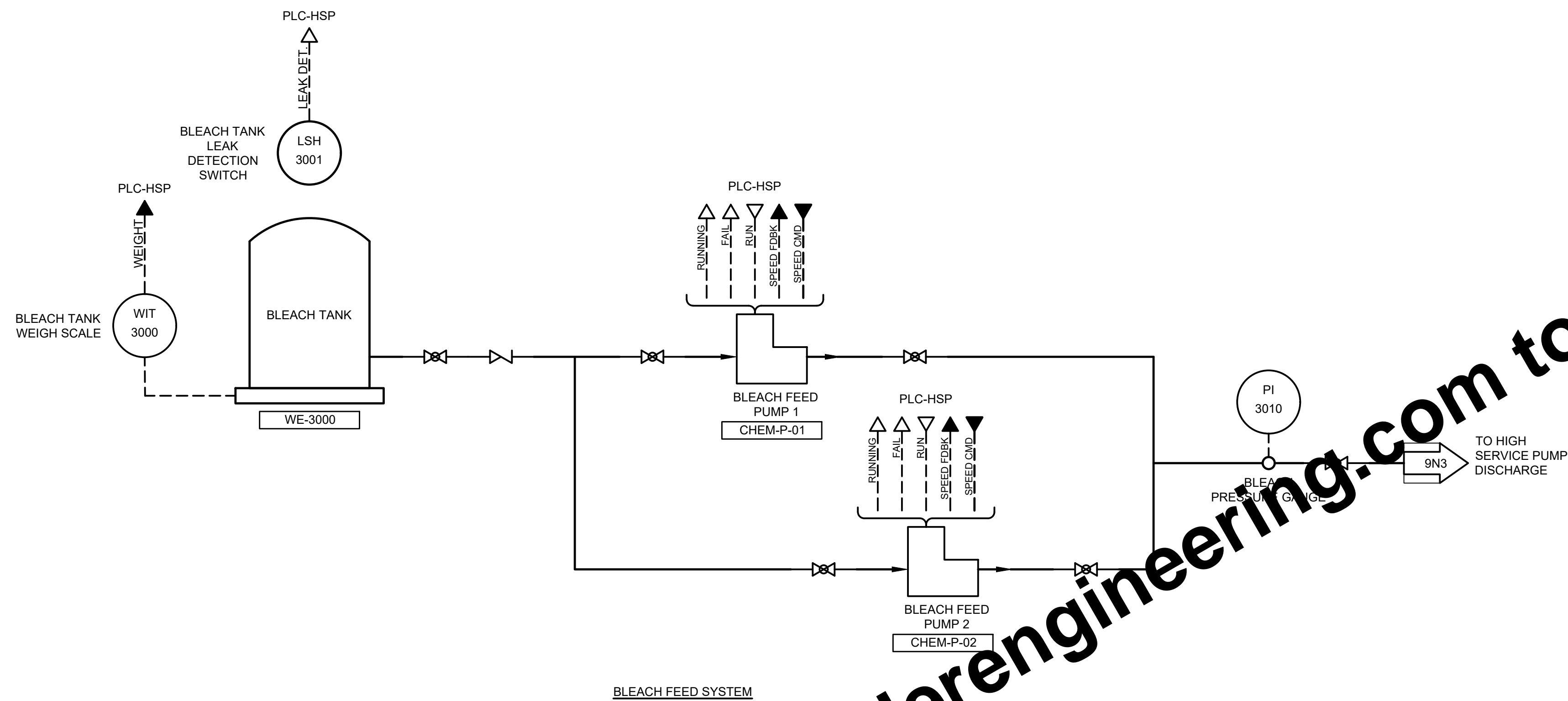

KEYED NOTES:  
 ① PROVIDED BY MANUFACTURER.

Drawing: X:\Hogale\_Oh\703222\_Hogale WTP\Contract B - Booster Station and WTP\DWG\Sheets\703222-PC-CD.dwg | Layout: 14 | Plotted: 01/21/26 @ 02:40:27 | Las Vegas By: BaileyH

SCALE VERIFICATION	DRAWN BY	BNH	NO.	DATE	INITIALS	REVISION DESCRIPTIONS
BAR IS ONE INCH LONG ON ORIGINAL DRAWING 	CHECKED BY	BDP				
	APPROVED BY	BNH				
	ISSUE DATE	FEBRUARY 2026				
	PROJECT NUMBER	703222-04-001				

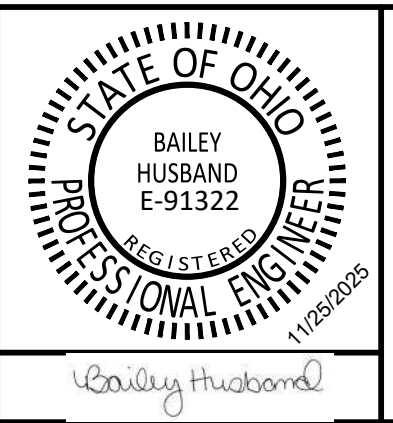

**WATER SYSTEM IMPROVEMENTS**

CONTRACT B NEW BOOSTER STATION AND WATER TREATMENT PLANT IMPROVEMENTS  
 VILLAGE OF HOGATE, OHIO

**CHEMICAL FEED PROCESS AND INSTRUMENTATION DIAGRAM**

SHEET NO.  
**9N4**

PAGE NO.  
**56**

DDAGW-4113

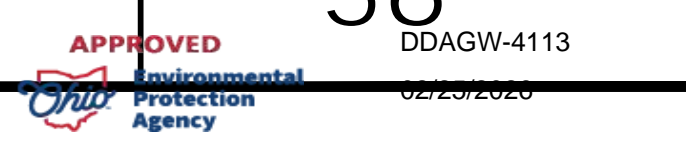

**SPLIT SYSTEM AIR CONDITIONER SCHEDULE**

MARK	LOCATION	SECTION	TYPE	MANUFACTURER	NOMINAL TONNAGE (TONS)	RATED CAPACITY (MBH)		ARI RATINGS				REFRIG-ERANT	OUTDOOR UNIT							INDOOR UNIT							CONTROL METHOD	REMARKS								
						COOLING	HEATING	SEER2	EER2	HSPF2	COP		TYPE	LBS	MODEL NUMBER	COMPRESSOR INVERTER	ELECTRICAL				WT (LBS)	ACCS.	DISCON.	MODEL NUMBER	STYLE	CFM			MIN. ESP (IN.WG)	RATED SENSIBLE HEAT RATIO	ELECTRICAL				WT (LBS)	ACCS.
SSAC-1	EXIST. HSP BLDG	15730	AIR COND.	mitsubishi-trane	2.0	24.0	N/A	21.3	12.2	N/A	N/A	R410A	8.0	PUY-A24NHA7	YES	208	1	19.0	26	151	1.2	BY DIV. 16	PKA-A24KA8	HIGH WALL	635/705/775	N/A	0.77	208	1	0.26	1.0	N/A	46	2	3	1,2
SSAC-2	NEW BOOSTER STATION	15730	AIR COND.	mitsubishi-trane	2.5	30.0	N/A	20.0	9.5	N/A	N/A	R410A	8.0	PUY-A30NHA7	YES	208	1	19.0	26	151	1.2	BY DIV. 16	PKA-A30KA8	HIGH WALL	635/705/775	N/A	0.70	208	1	0.26	1.0	N/A	46	2	3	
SSHP-1	NEW WATER TREATMENT BLDG.	15730	HEAT PUMP	mitsubishi-trane	1.5	18.0	21.6	18.7	12.4	9.2	3.3	R410A	3.0	SUZ-KA18NAHZ	YES	240	1	17.0	20	131	1,2,3	BY DIV. 16	SVZ-KP18NA	UPFLOW VERT.	471/573/675	0.80	0.93	240	1	2.4	17	30	2.3	1		

CONDITIONS FOR CAPACITY RATINGS:  
 COOLING: ENTERING AIR @ 80F DB / 67F WB, 95F OUTDOOR  
 HEATING: ENTERING AIR @ 70F DB, 47F OUTDOOR

MFG'R'S ACCESSORIES - OUTDOOR UNIT:  
 1. HAIL GUARDS  
 2. WALL BRACKET, STAINLESS STEEL  
 3. BASE PAN HEATER  
 4. 100% HEAT AT 5 DEG. F

MFG'R'S ACCESSORIES - INDOOR UNIT:  
 1. CONDENSATE PUMP  
 2. DISCONNECT SWITCH  
 3. ERV AND AUXILIARY HEAT CONTROLS

CONTROL METHOD:  
 1. MFG'R'S WIRED REMOTE 7-DAY PROGRAMMABLE CONTROLLER (PAR-40MAAU)  
 2. BACNET INTERFACE  
 3. REMOTE WIRED WALL-MOUNT THERMOSTAT WITH TEMP & RH READOUT.  
 4. WIRELESS CONTROLLER WITH TEMPERATURE AND HUMIDITY READOUT.

REMARKS:  
 1. INDOOR UNIT DISCONNECT BY DIV. 15.  
 2. MFG'R'S 2-STAGE ERV HEAT PACKAGE. DISCONNECT BY DIV. 15.

**FAN SCHEDULE**

MARK	LOCATION	SECTION	TYPE	MANUFACTURER	MODEL NUMBER	CFM	STATIC PRESSURE (IN.W.G.)	FAN RPM	BELT / DIRECT DRIVE	BHP	MOTOR				DISCONNECT	CONTROL METHOD	WALL/ROOF OPENING (IN X IN)	SONES	FINISH	WEIGHT (LBS)	FEATURES	REMARKS
											HP	VOLTS	PHASE	AMPS								
EF-1A & 1B	1A: CHEM. BLDG. - PHOSPHATE 1B: CHEM. BLDG. - BLEACH	15835	CENTRIF. UPBLAST	GREENHECK	CUBE-080-VG	180	0.31	1220	DIRECT	0.03	1/6	120	1	1.04	BY MFGR.	5	10"x10"	5.2	4	48	3,5,6	-

FAN TYPE:  
 1.) ROOF UPBLAST EXHAUSTER  
 2.) ROOF DOWNBLAST EXHAUSER  
 3.) WALL SUPPLY  
 4.) WALL EXHAUST  
 5.) IN-LINE  
 6.) CEILING EXHAUST FAN  
 7.) UTILITY FAN

MOTOR STARTER:  
 1.) BY DIVISION 16  
 2.) MFG'R'S MOTOR STARTER CONTROLLER (GREENHECK "VARIGREEN")  
 3.) VFD BY DIVISION 16

CONTROL METHOD:  
 1.) MANUFACTURER'S LINE VOLTAGE THERMOSTAT  
 2.) WALL SWITCH BY DIVISION 15  
 3.) WALL SWITCH BY DIVISION 16  
 4.) BMS INTERCONNECTION  
 5.) MFG'R'S HAND / OFF / AUTO

FINISH:  
 1.) ALUMINUM  
 2.) STAINLESS STEEL  
 3.) CONCRETE GRAY  
 4.) HI-PRO POLYESTER (CONCRETE GRAY)  
 5.) ALUMINUM W/ INDUSTRIAL EPOXY BASE COAT AND HI-PRO POLYESTER TOP COAT (CONCRETE GRAY)

FEATURES:  
 1.) EXTERNAL VIBRATION ISOLATORS  
 2.) CURB - STANDARD  
 3.) MOTORIZED DAMPERS  
 4.) BACKDRAFT DAMPERS  
 5.) SIDEWALL MOUNTING BRACKET  
 6.) BIRDSCREEN  
 7.) FILTERED SUPPLY WALL HOUSING  
 8.) CURB EXTENSION  
 9.) DAMPER TRAY

**ELECTRIC UNIT HEATER SCHEDULE**

MARK	LOCATION	SHEET	SECTION	TYPE	MANUFACTURER	MODEL NUMBER	CFM	ELECTRICAL					DISCONNECT	CONTROL METHOD	WALL/ROOF OPENING SIZE (IN X IN)	FINISH	WEIGHT (LBS)	FEATURES	REMARKS	
								KW	VOLTS	PHASE	AMPS	MCA								MOCP
EPUH-1	NEW BOOSTER STATION	6M1	15732	PROPELLER	MARLEY/QMARK	MUH-07-04	650	7.5	208	3	21	-	-	BY MFGR.	1	N/A	-	2	-	
ECRUH-1 A & 1B	1A: CHEM. BLDG. - BLEACH 1B: CHEM BLDG. - PHOSPHATE	3M1	15732	CHEMICAL RESISTANT	INDEECO	TRIAD	700	5	208	3	27	-	-	BY MFGR.	4.5	N/A	STAINLESS STEEL	56	1,5,6	-
EWUH-1	EXISTING HSP BLDG.	4M1	15762	WALL HEATER	MARLEY/QMARK	AWH4508F	-	4.8	208	1	23.1	-	-	BY MFGR.	2	14-1/2" x 18-1/2"	MFGR'S STANDARD	-	6	-
EWUH-2	NEW WATER TREATMENT BLDG.	4M1	15762	WALL HEATER	MARLEY/QMARK	AWH-4407F	-	3	240	1	12.5	-	-	INTEGRAL	2	14-1/2" x 18-1/2"	MFGR'S STANDARD	-	6	-

CONTROL METHOD:  
 1. LINE VOLTAGE WALL THERMOSTAT BY MFGR.  
 2. INTEGRAL ADJUSTABLE THERMOSTAT BY MFGR.  
 3. THERMOSTAT BY CONTRACTOR  
 4. TWO-STAGE INTEGRAL THERMOSTAT BY MFGR.  
 5. CORROSION RESISTANT WASH-DOWN STAT

FEATURES:  
 1. WALL MOUNTING SWIVEL BRACKET  
 2. CEILING MOUNTING HANGERS  
 3. RECESS TRIM  
 4. VERTICAL AND HORIZONTAL ADJUSTABLE LOUVERS  
 5. PILOT LIGHT  
 6. INTEGRAL POWER DISCONNECT SWITCH

**GAS UNIT HEATER SCHEDULE**

MARK	LOCATION	SECTION	TYPE	MANUFACTURER	MODEL NUMBER	INPUT (MBH)	OUTPUT (MBH)	CFM	SOUND PRESSURE (dBA)	ELECTRICAL					DISCONNECT	CONTROL METHOD	FINISH	WEIGHT (LBS)	FEATURES	REMARKS
										VOLTS	PHASE	AMPS	MCA	MOCP						
GFUH-1	NEW WATER TREATMENT BLDG.	15760	PROPELLER	REZNR	UDXC-75	75	62.3	961	49	120	1	3.7	-	15	MFGR'S INTEGRAL	1	MFGR'S STD.	76	1,2,4,6	2-STAGE

CONTROL METHOD:  
 1. LINE VOLTAGE WALL THERMOSTAT BY MFGR.  
 2. INTEGRAL ADJUSTABLE THERMOSTAT BY MFGR.  
 3. THERMOSTAT BY CONTRACTOR  
 4. TWO-STAGE INTEGRAL THERMOSTAT BY MFGR.

FEATURES:  
 1. SEPARATED COMBUSTION W/ MFGR'S VENT KIT  
 2. CEILING MOUNTING HANGERS  
 3. RECESS TRIM  
 4. VERTICAL AND HORIZONTAL ADJUSTABLE LOUVERS  
 5. PILOT LIGHT  
 6. INTEGRAL POWER DISCONNECT SWITCH

For Viewing Purposes Only - Visit [www.wesslerengineering.com](http://www.wesslerengineering.com) to Purchase

SCALE VERIFICATION  BAR IS ONE INCH LONG ON ORIGINAL DRAWING	DRAWN BY	CLG	NO.	DATE	INITIALS	REVISION DESCRIPTIONS
	CHECKED BY	SPR				
	APPROVED BY	WCM				
	ISSUE DATE	FEBRUARY 2026				
	PROJECT NUMBER	703222-04-001				

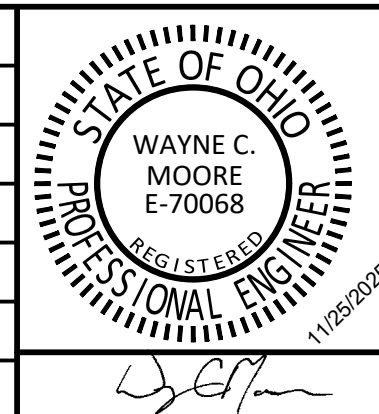

**WATER SYSTEM IMPROVEMENTS**  
 CONTRACT B NEW BOOSTER STATION AND WATER TREATMENT PLANT IMPROVEMENTS  
 VILLAGE OF HOLGATE, OHIO

**MECHANICAL SCHEDULES**

SHEET NO.  
**10M1**  
 PAGE NO.  
**57**  
 DDAGW-4113



Drawing: X:\Highgate\_C\703222\Sheets\703222-MD-HVAC.dwg | Layout: 10M1 | Printer: 01/21/26 @ 02:35:34 | LastSavedBy: CursiG

Drawing: X:\Hogate\_Cht\703222\_Hogate WTP\Contract B - Booster Station and WTP\DWG\Sheets\703222-HVAC.dwg | Layout: 10M2 | Plotter: 01/21/26 @ 02:25:37 | LastSavedBy: ChrisG

For Viewing Purposes Only - Visit [www.wesslerengineering.com](http://www.wesslerengineering.com) to Purchase

ENERGY RECOVERY VENTILATOR SCHEDULE																								
MARK	LOCATION	SECTION	TYPE	MFR	MODEL	SUPPLY & EXHAUST AIRFLOW (CFM)	SUPPLY & EXHAUST E.S.P. (IN.W.G.)	SUPPLY & EXHAUST FILTERS (MERV)	SUMMER				WINTER				ELECTRICAL					WT (LBS)	FEATURES	CONTROL METHOD
									OUTDOOR E.A.T. DB/WB (F)	EXHAUST E.A.T. DB/WB (F)	SUPPLY L.A.T. DB (F)	ADJUSTED SENSIBLE RECOVERY EFFICIENCY	OUTDOOR E.A.T. DB (F)	EXHAUST E.A.T. DB/WB (F)	SUPPLY L.A.T. DB/WB (F)	ADJUSTED SENSIBLE RECOVERY EFFICIENCY	VOLTS	PHASE	AMPS	MOCP	DISCON.			
ERV-1	WATER TREATMENT BLDG.	15745	COMPACT FIXED CORE	GREENHECK	SYNC-180	100	0.5	6	95.0/79.0	75.0/63.0	80.4	51%	-13.0	71.6/26.0	40.3	63%	120	1	1.4	20	BY DIV. 15	34	1,2,3	1
NOTE: SCHEDULED UNIT MUST BE "MIRRORED" IN THE FIELD IN ACCORDANCE WITH THE MANUFACTURER'S INSTRUCTIONS.												FEATURES 1. INTEGRAL DEFROST 2. HVAC SYSTEM INTERLOCK 3. HARDWIRED W/ DISCON. AT UNIT BY DIV. 15				CONTROL METHOD: 1. INTERLOCKED WITH HVAC UNIT SERVED.								

ROOF INTAKE AND RELIEF VENTILATOR SCHEDULE																					
MARK	LOCATION	SECTION	TYPE	MANUFACTURER	MODEL NUMBER	THROAT WIDTH (IN)	THROAT LENGTH (IN)	HOOD WIDTH (IN)	HOOD LENGTH (IN)	BASE HEIGHT (IN)	CFM	THROAT VELOCITY (FPM)	STATIC PD (IN.W.G.)	CONFIG.	FINISH	CURB	DAMPER	CURB EXTENSION	WEIGHT (LBS)	REMARKS	
RRV-1	WATER TREATMENT BLDG.	15854	RELIEF	GREENHECK	FGR	8	8	18	24	5	100	0.007	0.007	DUCTED	MFGR'S STD.	12" SLOPE	NO	NO	37	BIRDSCREEN	
NOTE: CURB FOR STANDING SEAM ROOF; EXTERIOR TO BE PAINTED BY MFR WITH HI-PRO POLYESTER PAINT IN COLOR BY OWNER.																					

GRILLES, REGISTERS AND DIFFUSERS SCHEDULE																	
MARK	LOCATION	SECTION	TYPE	MANUFACTURER	MODEL NUMBER	PANEL/ FACE DIMENSIONS	DUCT BORDER	MAX CFM	STATIC PD (IN.W.G.)	MAX NC	THROW @50 FPM (FT)	DAMPER	FINISH	REMARKS			
SD-1	WATER TREATMENT BLDG.	15850	PANEL DIFFUSER	PRICE	SPD	24" x 24"	LAY-IN	157	0.041	<15	6	NO	WHITE	-			
SD-2	WATER TREATMENT BLDG.	15850	PANEL DIFFUSER	PRICE	SPD	24" x 24"	LAY-IN	279	0.074	<19	9	NO	WHITE	-			
SG-1	WATER TREATMENT BLDG.	15850	DOUBLE DEFL.	PRICE	SPD	6" x 6"	1-1/4"	125	0.071	15	19	NO	WHITE	FRONT BLADES HORIZONTAL			
RG-1	WATER TREATMENT BLDG.	15850	EGGCRATE	PRICE	SPD	22" x 10"	LAY-IN	900	0.047	<15	-	-	WHITE	FRONT BLADES HORIZONTAL			
RG-2	WATER TREATMENT BLDG.	15850	EGGCRATE	PRICE	SPD	22" x 22"	LAY-IN	2000	0.047	<15	-	-	WHITE	FRONT BLADES HORIZONTAL			
EG-1	WATER TREATMENT BLDG.	15850	SINGLE DEFL.	PRICE	SPD	8" x 8"	1-1/4"	195	0.069	<21	-	-	WHITE	45 DEG. DEFLECTION			
TG-1	WATER TREATMENT BLDG.	15850	SINGLE DEFL.	PRICE	SPD	22" x 10"	LAY-IN	670	0.069	<25	-	-	WHITE	45 DEG. DEFLECTION			
NOTE: PROVIDE RETURN AIR CANOPY FOR EACH EGGCRATE RETURN NOT HAVING A TRANSFER BOOT; EQUIVALENT TO PRICE RAC																	

LOUVER SCHEDULE													
MARK	LOCATION	SECTION	TYPE	MANUFACTURER	MODEL NUMBER	WIDTH (IN)	HEIGHT (IN)	FREE AREA (FT²) / FREE AREA VELOCITY (FPM)	STATIC PRESSURE LOSS (IN.W.G.)	MATERIAL (A)	FINISH (B)	REMARKS (C)	
D-1A & 1B	1A: CHEM. BLDG. - BLEACH 1B: CHEM. BLDG. - PHOSPHATE	15852	DRAINABLE BLADE	GREENHECK	ESD-635	24	12	0.46 / 388	0.023	2	3	1,2	
D-1L-2	WATER TREATMENT BLDG.	15852	DRAINABLE BLADE	GREENHECK	ESD-635	18	12	0.33 / 301	0.014	1	3	1,2	
(A) MATERIAL:				(B) FINISH:				(C) REMARKS:					
1. ALUMINUM 2. STAINLESS STEEL 304				1. CLEAR ANODIZED 2. HI-PRO POLYESTER, COLOR CONCRETE GRAY 3. HI-PRO POLYESTER, CUSTOM COLOR BY ENGR.				1. BIRD SCREEN - STAINLESS STEEL 2. CONTRACTOR SHALL COORDINATE FRAME TYPE WITH GENERAL BUILDING ENVELOPE CONTRACTOR					

DAMPER SCHEDULE										
MARK	LOCATION	SECTION	MANUFACTURER	MODEL NUMBER	WIDTH (IN)	HEIGHT (IN)	MATERIAL (A)	ACTUATOR (B)	CONTROL (C)	REMARKS (D)
D-1A & 1B	1A: CHEM. BLDG. - PHOSPHATE 1B: CHEM. BLDG. - BLEACH	15820	GREENHECK	ICD-45	10	10	2	2	1	1,2
D-2A & 2B	2A: CHEM. BLDG. - PHOSPHATE 2B: CHEM. BLDG. - BLEACH	15820	GREENHECK	ICD-45	24	12	2	2	1	1,2
D-3	WATER TREATMENT BLDG.	15820	GREENHECK	ICD-45	18	12	1	2	5	1,2
D-4	WATER TREATMENT BLDG.	15820	GREENHECK	ICD-45	8	8	1	2	5	1,2
(A) MATERIAL					(B) ACTUATOR		(C) CONTROL:			(D) REMARKS:
1. ALUMINUM 2. STAINLESS STEEL 304					1. 24V 2. 120V		1.) INTERLOCKED TO EXHAUST FAN 2.) WALL SWITCH BY DIVISION 15 3.) WALL SWITCH BY DIVISION 16 4.) BMS INTERCONNECTION 5.) INTERLOCKED TO ERV			1.) ACTUATOR SPRING RETURN, FAIL CLOSED. 2.) END SWITCH

SCALE VERIFICATION  BAR IS ONE INCH LONG ON ORIGINAL DRAWING 	DRAWN BY	CLG	NO.	DATE	INITIALS	REVISION DESCRIPTIONS
	CHECKED BY	SPR				
	APPROVED BY	WCM				
	ISSUE DATE	FEBRUARY 2026				
	PROJECT NUMBER	703222-04-001				

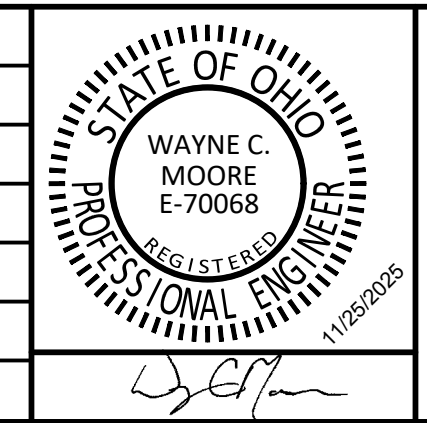

<b>WATER SYSTEM IMPROVEMENTS</b>
CONTRACT B NEW BOOSTER STATION AND WATER TREATMENT PLANT IMPROVEMENTS VILLAGE OF HOGATE, OHIO
<b>MECHANICAL SCHEDULES</b>

SHEET NO. <b>10M2</b>
PAGE NO. <b>58</b>
DDAGW-4113

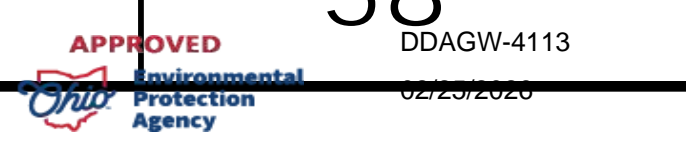

**SEQUENCES OF CONTROL**

**CHEMICAL BUILDING**

1. GENERAL:

1.1. SEQUENCE IS IDENTICAL FOR BOTH BLEACH ROOM AND PHOSPHATE ROOM.

1.2. SPACES ARE HEATED AND VENTILATED. FANS SIZED FOR 12 AIR CHANGES PER HOUR.

2. EXHAUST FAN:

2.1. FAN CONTROLLED BY EXTERIOR WALL SWITCH AND A SINGLE STAGE LINE VOLTAGE THERMOSTAT MOUNTED IN THE SPACE. A UNIT-MOUNTED DISCONNECT SHALL BE PROVIDED BY THE FAN MANUFACTURER.

2.2. EXTERIOR WALL SWITCH SHALL BE A "HAND/AUTO" TYPE TO ALLOW FAN TO BE CONTROLLED BY THERMOSTAT (NORMAL / AUTOMATIC MODE) OR WALL SWITCH (HAND / OVERRIDE MODE).

2.3. IN AUTO MODE, FAN SHALL BE ENERGIZED WHENEVER SPACE TEMPERATURE RISES ABOVE 85F, AND WILL BE DE-ENERGIZED BELOW THE DEADBAND.

2.4. WHEN EXTERIOR WALL SWITCH SET TO HAND MODE, EXHAUST SHALL BE COMMANDED ON REGARDLESS OF SPACE TEMPERATURE.

2.5. DAMPERS: WHENEVER FAN IS COMMANDED ON, DAMPERS AT FAN AND LOUVERS SHALL FIRST BE OPENED, AND ONCE END SWITCHES OF BOTH DAMPERS ARE MET, FAN SHALL BE ENERGIZED. WHEN FAN IS COMMANDED OFF, THE FAN SHALL BE DE-ENERGIZED AND BOTH DAMPERS SHALL BE CLOSED.

3. UNIT HEATER:

3.1. HEATER SHALL BE INDEXED ON BY TWO STAGE WALL MOUNTED CORROSION RESISTANT THERMOSTAT.

3.2. THERMOSTAT SET POINT 55F (ADJ.)

3.3. UNIT HEATERS SIZED TO MAINTAIN SPACE TEMP DURING OCCUPANCY WHILE VENTILATING, AT 70F DIFFERENCE FROM OUTDOOR TEMPERATURE

**EXISTING HIGH SERVICE BUILDING**

1. GENERAL:

1.1. SPACE IS HEATED AND COOLED.

2. HEATING:

2.1. ELECTRIC WALL HEATER IS CONTROLLED BY INTEGRAL THERMOSTAT, SET TO MAINTAIN SPACE AT 55F (ADJ.)

3. COOLING:

3.1. SPLIT SYSTEM AIR CONDITIONER SHALL BE CONTROLLED VIA MANUFACTURER'S WALL MOUNTED THERMOSTAT TO MAINTAIN THE SPACE AT 82F (ADJ.)

3.2. THERMOSTAT SHALL DISPLAY SPACE TEMPERATURE.

**NEW BOOSTER STATION**

1. GENERAL:

1.1. SPACE IS HEATED AND COOLED.

2. HEATING:

2.1. CEILING HUNG ELECTRIC UNIT HEATER IS CONTROLLED BY MOUNTED LINE VOLTAGE THERMOSTAT, SET TO MAINTAIN SPACE AT 55F (ADJ.)

3. COOLING:

3.1. SPLIT SYSTEM AIR CONDITIONER SHALL BE CONTROLLED VIA MANUFACTURER'S WALL MOUNTED THERMOSTAT TO MAINTAIN THE SPACE AT 82F (ADJ.)

3.2. THERMOSTAT SHALL DISPLAY SPACE TEMPERATURE.

**NEW WATER TREATMENT BUILDING**

1. GENERAL:

1.1. BUILDING CONSISTS OF TWO SEPARATE SPACES. GARAGE IS HEATED, OFFICE AREA IS HEATED AND COOLED.

2. GARAGE:

2.1. GAS FIRED UNIT HEATER IS CONTROLLED BY WALL MOUNTED THERMOSTAT, SET TO MAINTAIN SPACE AT 55F (ADJ.)

3. OFFICE AREA:

3.1. SYSTEM CONSISTS OF:

3.1.1. VERTICAL SPLIT SYSTEM HEAT PUMP WITH TWO-STAGE AUXILIARY ELECTRIC HEAT.

3.1.2. VENTILATION (OUTDOOR AIR) PROVIDED BY AIR-TO-AIR FIXED MEDIA TYPE ENERGY RECOVERY VENTILATOR AS SCHEDULED. THE ERV PRE-CONDITIONS THE OUTDOOR AIR WITH THE BUILDING EXHAUST AIR AND SERVES THE PRE-CONDITIONED AIR TO THE SPLIT SYSTEM RETURN DUCT.

3.1.3. OCCUPANCY SENSORS (BY DIV. 16) LOCATED IN HALLWAY, OFFICE, AND BREAKROOM.

3.1.4. AN ELECTRIC WALL HEATER IS PROVIDED AT THE MAIN OFFICE ENTRANCE AND OPERATES OFF MANUFACTURER'S INTEGRAL THERMOSTAT.

3.2. SPLIT SYSTEM HEAT PUMP

3.2.1. UNIT OPERATES OFF MANUFACTURER'S PROGRAMMABLE THERMOSTAT LOCATED IN FRONT OFFICE, AS NEEDED TO MAINTAIN SPACE AT HEATING AND COOLING SETPOINTS.

3.2.2. OCCUPANCY TEMPERATURE SETPOINTS:

3.2.2.1. OCCUPIED AND UNOCCUPIED HOURS AND/OR ANY SETBACK HOURS TO BE COORDINATED WITH OWNER.

3.2.2.2. OCCUPIED SETPOINTS: HEATING = 68F AND COOLING = 74F.

3.2.2.3. UNOCCUPIED SETPOINTS: HEATING = 62F AND COOLING = 80F, SETPOINTS ADJUSTABLE.

3.2.3. BACKUP ELECTRIC HEAT: FOR LOW OUTDOOR AIR TEMPERATURES, HEAT PUMP WILL SWITCH TO AUXILIARY ELECTRIC HEAT, AND STAGE HEAT USING INTERNAL CONTROLS.

3.2.4. FAN OPERATION:

3.2.4.1. OCCUPIED HOURS: INDOOR UNIT FAN SHALL OPERATE CONTINUOUSLY.

3.2.4.2. UNOCCUPIED HOURS: PROGRAM SETPOINT TO "AUTO"; FAN SHALL RUN ONLY WHEN THERE IS A CALL FOR HEATING OR COOLING.

3.2.4.3. THE SSHP-1 INDOOR UNIT FAN AND THE ERV SHALL BE INTERLOCKED, SUCH THAT WHENEVER THE ERV IS ENERGIZED, THE SSHP-1 INDOOR UNIT FAN IS ENERGIZED AND VICE VERSA.

3.3. ENERGY RECOVERY VENTILATOR:

3.3.1. UNIT IS ON, INTEGRAL OUTDOOR AIR AND EXHAUST AIR FANS ARE OPERATING. WHEN UNIT IS OFF, UNIT FANS ARE OFF.

3.3.2. VENTILATION "OCCUPIED" PERIODS:

3.3.2.1. SSHP-1 INDOOR UNIT FAN AND ERV SHALL BE INTERLOCKED SO THAT VENTILATION AIR WILL BE CIRCULATED BY THE INDOOR UNIT FAN WHENEVER ERV OPERATION IS REQUIRED.

3.3.2.2. ERV SHALL OPERATE WHENEVER THE BUILDING IS OCCUPIED. IF SSHP-1 CONTROLLER DOES NOT HAVE A VENTILATION SEQUENCE IN ADDITION TO SEPARATE NIGHT SETBACK CONTROLS, THEN ERV SHALL ALSO OPERATE WHENEVER OCCUPANCY SENSORS (ANY ONE OR MORE SENSORS) ARE PROVIDING AN "OCCUPIED" SIGNAL.

3.3.3. VENTILATION "UNOCCUPIED" PERIODS:

3.3.3.1. ERV IS TO BE OFF REGARDLESS OF STATUS OF HEAT PUMP INDOOR UNIT FAN.

3.4. MOTORIZED OUTDOOR AIR AND EXHAUST AIR DAMPERS:

3.4.1. PRIOR TO INDEXING THE ERV TO "ON", DAMPERS D-3 AND D-4 SHALL BE PROVEN OPEN. DAMPERS SHALL CLOSE WHENEVER ERV IS POWERED OFF.

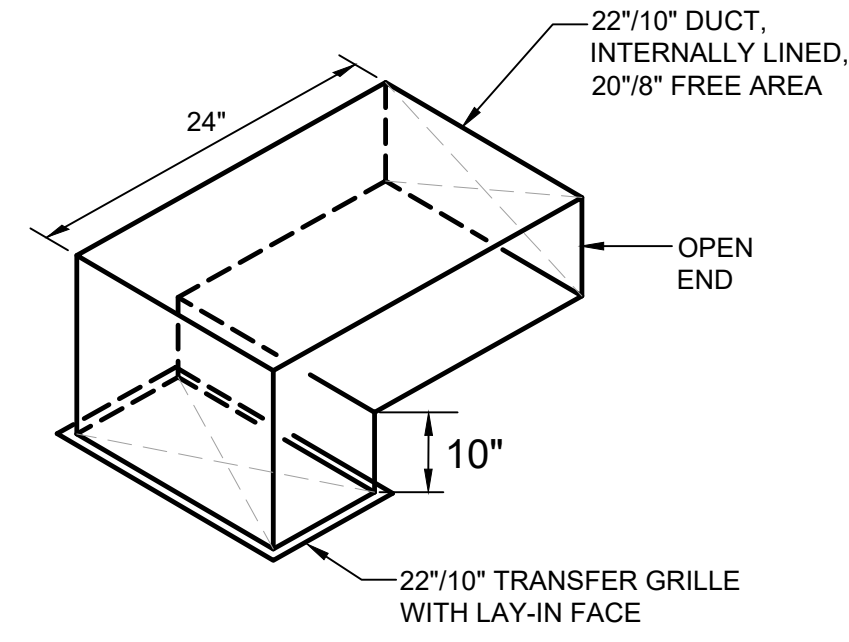

**RETURN/TRNSFR AIR BOOT DETAIL**  
SCALE: NONE

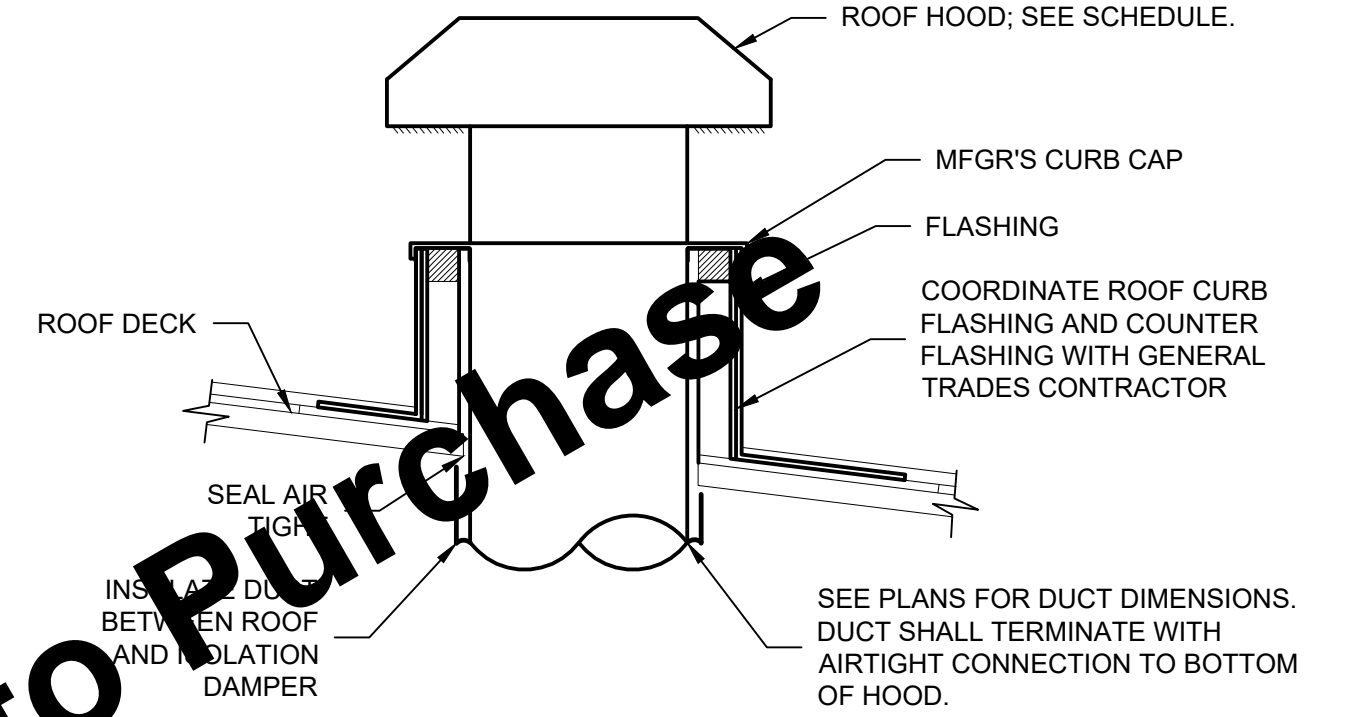

**ROOF MOUNTED RELIEF HOOD DETAIL**  
SCALE: NONE

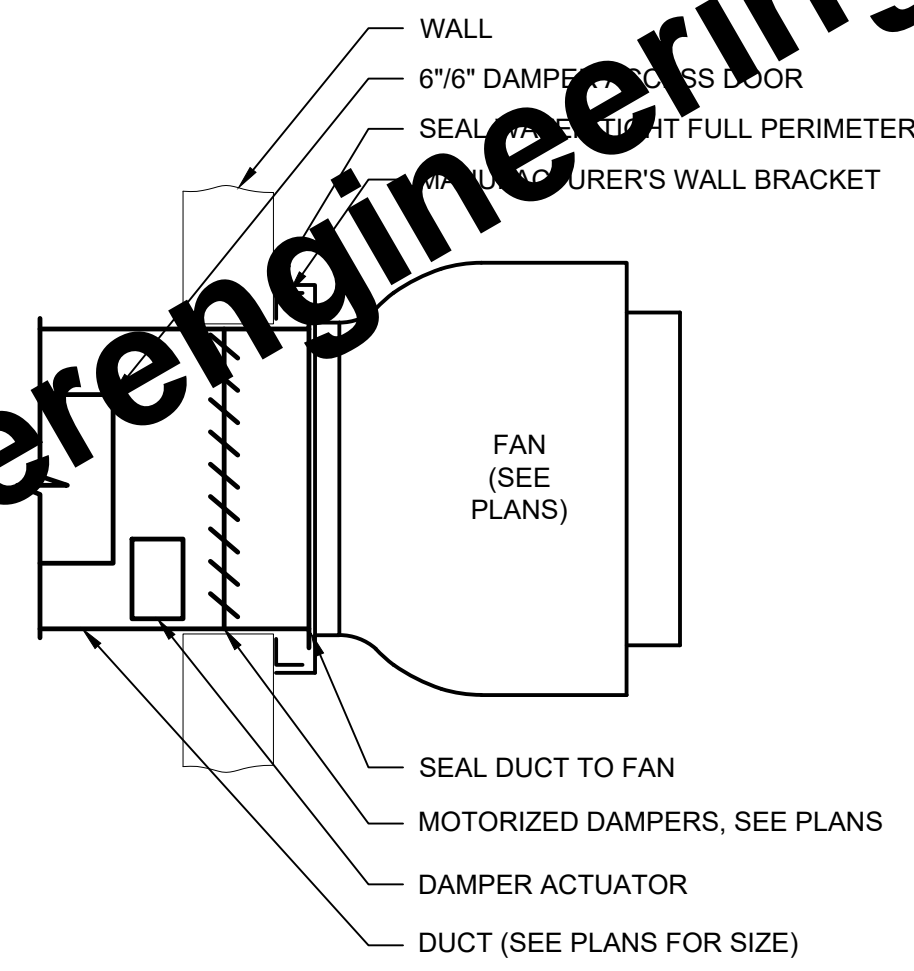

**SIDEWALL EXHAUST FAN DETAIL**  
SCALE: NONE

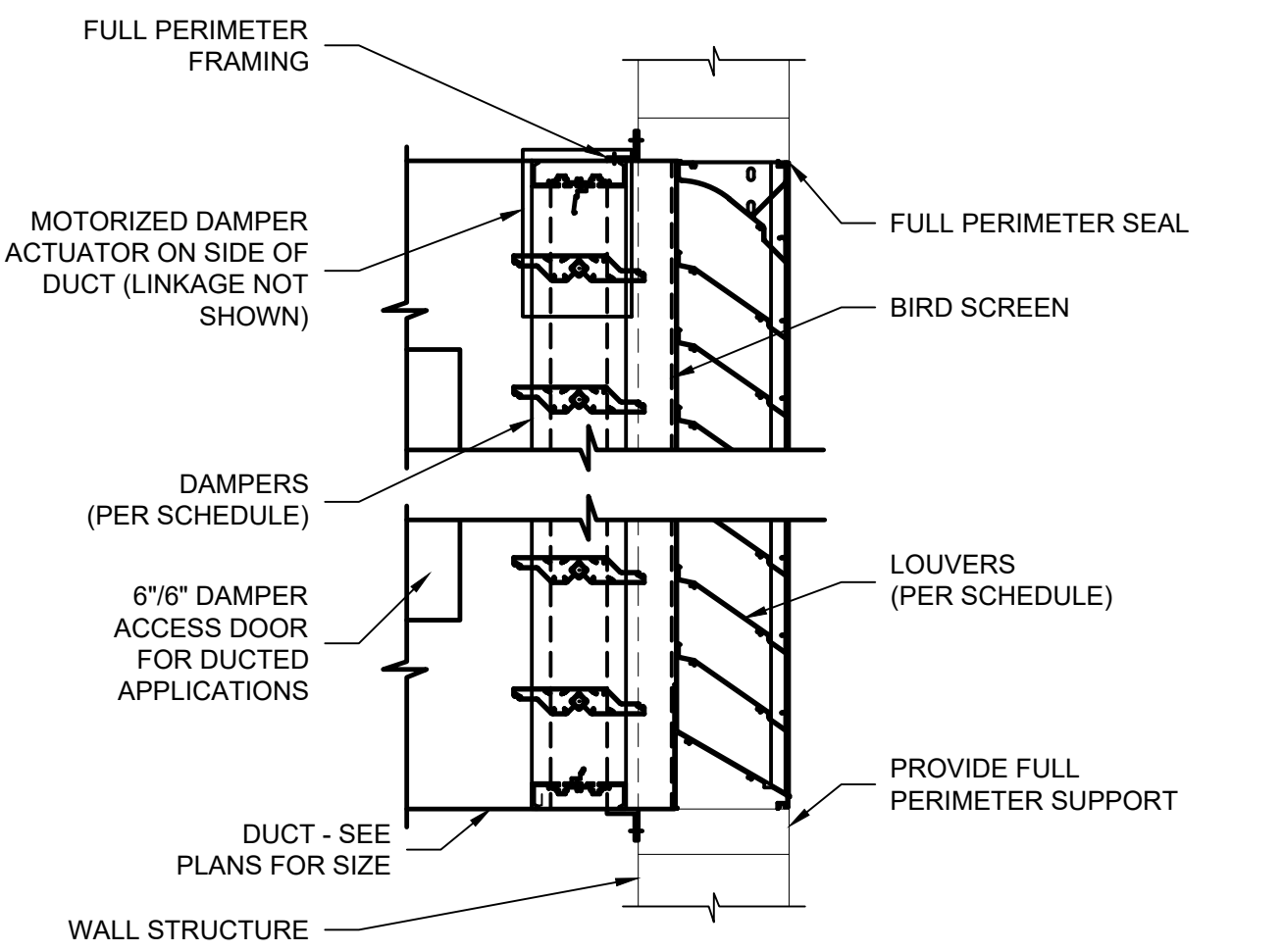

**DAMPER AND LOUVER INSTALLATION DETAIL**  
SCALE: NONE

For Viewing Purposes Only - visit www.wesslerengineering.com to purchase

SCALE VERIFICATION	DRAWN BY	CLG	NO.	DATE	INITIALS	REVISION DESCRIPTIONS
BAR IS ONE INCH LONG ON ORIGINAL DRAWING	CHECKED BY	SPR				
	APPROVED BY	WCM				
	ISSUE DATE	FEBRUARY 2026				
	PROJECT NUMBER	703222-04-001				

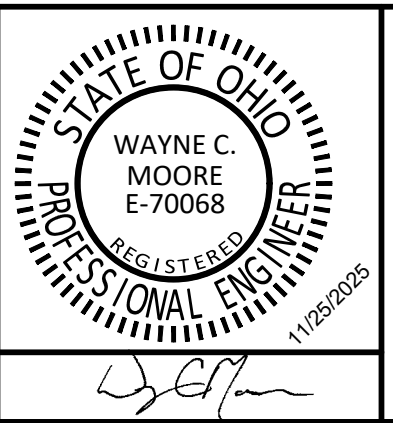

**WATER SYSTEM IMPROVEMENTS**

CONTRACT B NEW BOOSTER STATION AND WATER TREATMENT PLANT IMPROVEMENTS  
VILLAGE OF HOLGATE, OHIO

---

**MECHANICAL DETAILS AND SEQUENCES**

SHEET NO.  
**10M3**

PAGE NO.  
**59**

DDAGW-4113  
02/20/2026

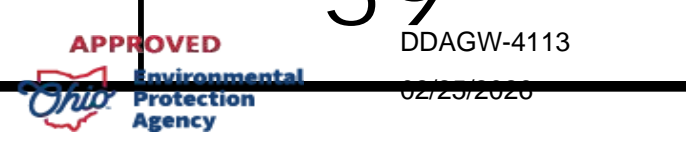

Drawing: X:\Holgeatle\_Cht\703222\_Holgeatle WTP\Contract B - Booster Station and WTP\DWG Sheets\703222-04-001-HV-3.dwg | Layout: 10M3 | Plotter: 01/21/26 @ 02:35:00 | LaserWriter: C:\Windows\System32\cmd.exe